

CLAY WEDGING TABLE

WT714 (OAK OR MAPLE)

ASSEMBLY INSTRUCTIONS

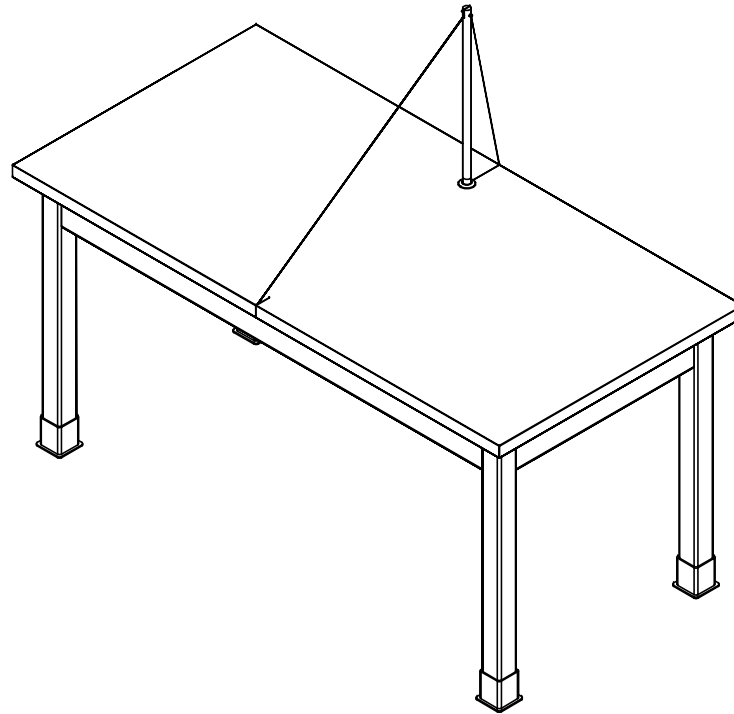

NOTE:

1. MODEL VIEWS MAY NOT REPRESENT EXACT MODEL PURCHASED

| | | | |
|---------|-----|-----------|--------|
| DWN BY: | EMK | DWN DATE: | 3/4/14 |
| APR BY: | | DATE APR: | |
| APR BY: | | DATE APR: | |

UNLESS OTHERWISE SPECIFIED
DIMENSION ARE IN INCHES
CABINET SQUARENESS ± .0625
FRACTIONAL VALUES ± 1/32"
- ALL VALUES ± OVERALL -



300 South Krueger Street
Suring, WI 54174
diversifiedwoodcrafts.com

TITLE:
CLAY WEDGING TABLE
ASSEMBLY INSTRUCTIONS

| A | DESCRIPTION | DATE | NAME | ECN NO. |
|------|-------------------------------|--------|------|---------|
| | CREATED ASSEMBLY INSTRUCTIONS | 3/4/14 | EMK | - |
| REV. | | | | |

REVISION LEVEL

THIS DRAWING IS THE SOLE PROPERTY OF
DIVERSIFIED WOOD CRAFTS. IT MAY NOT
BE ALTERED OR CHANGED WITHOUT
PERMISSION

DRAWING NUMBER:

WT714

SCALE:

NTS

SHEET:

1 OF 4

REVISION:

REV A

TOOLS REQUIRED

1/2" WRENCH

1/2" SOCKET AND TORQUE WRENCH - OPTIONAL

ASSEMBLY COMPONENTS

| ITEMS INCLUDED | PART # | PART DESCRIPTION | QTY |
|---------------------------------|--------|-------------------------------------|-----|
| TOP, APRON, ROD SOCKET ASSEMBLY | N/A | TOP ASSEMBLY (FACTORY ASSEMBLED) | 1 |
| LEGS (OAK) | 500100 | LEG,OAK, W/ HANGER BOLT AND T NUT | 4 |
| LEGS (MAPLE) | 500110 | LEG,MAPLE, W/ HANGER BOLT AND T NUT | 4 |
| LEG LEVELERS | 100079 | LEG LEVELERS,BLK BASE 1 | 4 |
| LEG BOOT | 100076 | LEG BOOT,BLK RUBBER | 4 |
| EYE BOLT | 248603 | BOLT,1/4-20X1 1/2", EYE BOLT | 1 |
| WASHER - EYE BOLT | 100451 | WASHER,5/16" FLAT ZINC PLATED | 1 |
| HEX NUT - EYE BOLT | 100483 | NUT,1/4-20 HEX ZINC | 1 |
| TURNBUCKLE | 248601 | TURNBUCKLE,HOOK&EYE,3/8"-16X7.5"L | 1 |
| ROD | 248214 | ROD,UPRIGHT,.75 DIAM X 22.00L | 1 |
| WIRE | 247067 | WIRE,.033 DIAM,304 STAINLESS | 8 |
| WIRE SLEEVE | 247068 | WIRE,SLEEV.033 DIAM,304 STAINLESS | 4 |
| CANVAS TOP | 248215 | CANVAS,TOP COVER,30X60,W/VELCRO | 1 |

NOTE:

1.

| | | | |
|---------|-----|-----------|--------|
| DWN BY: | EMK | DWN DATE: | 3/4/14 |
| APR BY: | | DATE APR: | |
| APR BY: | | DATE APR: | |

UNLESS OTHERWISE SPECIFIED
DIMENSION ARE IN INCHES
CABINET SQUARENESS ± .0625
FRACTIONAL VALUES ± 1/32"
- ALL VALUES ± OVERALL -



300 South Krueger Street
Suring, WI 54174
diversifiedwoodcrafts.com

TITLE:
CLAY WEDGING TABLE
TOOLS AND ASSEMBLY COMPONENTS

| A | DESCRIPTION | DATE | NAME | ECN NO. |
|------|-------------------------------|--------|------|---------|
| | CREATED ASSEMBLY INSTRUCTIONS | 3/4/14 | EMK | - |
| REV. | | | | |

THIS DRAWING IS THE SOLE PROPERTY OF
DIVERSIFIED WOOD CRAFTS. IT MAY NOT
BE ALTERED OR CHANGED WITHOUT
PERMISSION

| | | | | | | | |
|-----------------|-------|--------|-----|--------|--------|-----------|-------|
| DRAWING NUMBER: | WT714 | SCALE: | NTS | SHEET: | 2 OF 4 | REVISION: | REV A |
|-----------------|-------|--------|-----|--------|--------|-----------|-------|

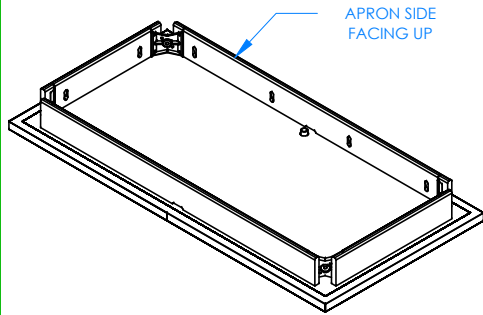

APRON SIDE
FACING UP

STEP 1:

LAY TOP ASSEMBLY ON FLOOR WITH APRON SIDE FACING UP. BE SURE TOP ASSEMBLY IS ON A CLEAN SURFACE TO PREVENT DAMAGE.

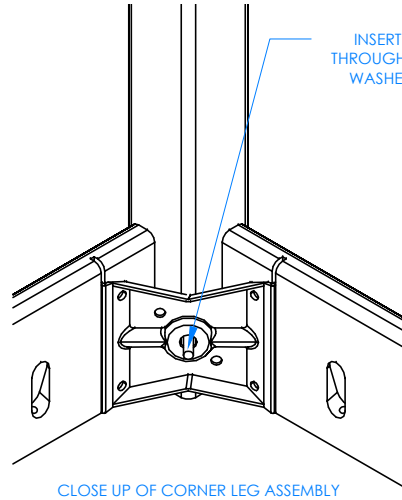

INSERT HANGER BOLT
THROUGH HERE WITH LOCK
WASHER AND HEX NUT

CLOSE UP OF CORNER LEG ASSEMBLY

STEP 2:

TAKE ONE OF THE LEGS, PLACE IT INTO THE CORNER OF APRON ASSEMBLY. INSERT HANGER BOLT THROUGH THE CORNER BRACKET AND PUT ON WASHER AND THE NUT. USING A 1/2" WRENCH OR 1/2" SOCKET AND TORQUE WRENCH, SCREW ON NUT USING A MINIMUM OF 12FT LBS BUT NOT TO EXCEED 17FT LBS. REPEAT FOR THE OTHER 3 LEGS.

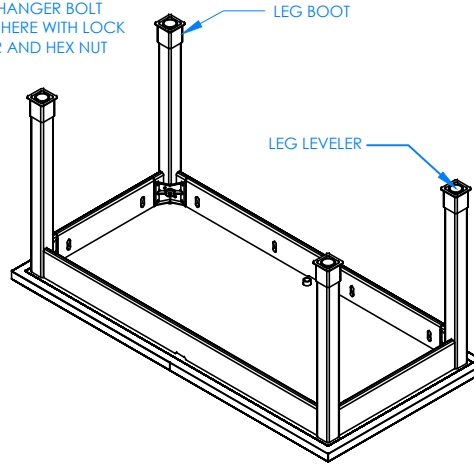

LEG BOOT

LEG LEVELER

STEP 3:

WITH ALL THE LEGS IN PLACE AND WITH THE TABLE STILL UPSIDE DOWN, SLIDE LEG BOOTS DOWN TO THE FLOOR WITH FLARED END TOWARD BOTTOM OF LEG. SCREW LEG LEVELERS INTO T-NUT IN THE BOTTOM OF LEG.

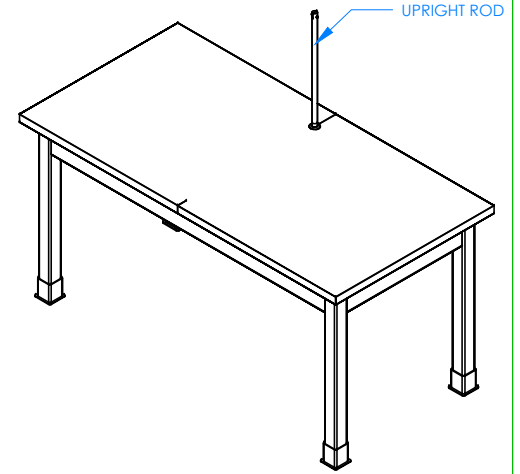

UPRIGHT ROD

STEP 4:

TURN TABLE OVER SO TOP IS UP. ADJUST LEG LEVELERS TO LEVEL TABLE. SLIDE LEG BOOTS DOWN TO THE FLOOR. INSERT UPRIGHT ROD THROUGH THE ROD SOCKET IN THE TABLE TOP.

NOTE:

- 1.

| | | | |
|---------|-----|-----------|--------|
| DWN BY: | EMK | DWN DATE: | 3/4/14 |
| APR BY: | | DATE APR: | |
| APR BY: | | DATE APR: | |

UNLESS OTHERWISE SPECIFIED
DIMENSION ARE IN INCHES
CABINET SQUARENESS ± .0625
FRACTIONAL VALUES ± 1/32"
- ALL VALUES ± OVERALL -



300 South Krueger Street
Suring, WI 54174
diversifiedwoodcrafts.com

TITLE:
CLAY WEDGING TABLE
ASSEMBLY INSTRUCTIONS

| REV. | DESCRIPTION | DATE | NAME | ECH NO. |
|----------------|-------------------------------|--------|------|---------|
| A | CREATED ASSEMBLY INSTRUCTIONS | 3/4/14 | EMK | - |
| REVISION LEVEL | | | | |

THIS DRAWING IS THE SOLE PROPERTY OF
DIVERSIFIED WOOD CRAFTS. IT MAY NOT
BE ALTERED OR CHANGED WITHOUT
PERMISSION

DRAWING NUMBER:

WT714

| | | |
|--------|--------|-----------|
| SCALE: | SHEET: | REVISION: |
| NTS | 3 OF 4 | REV A |

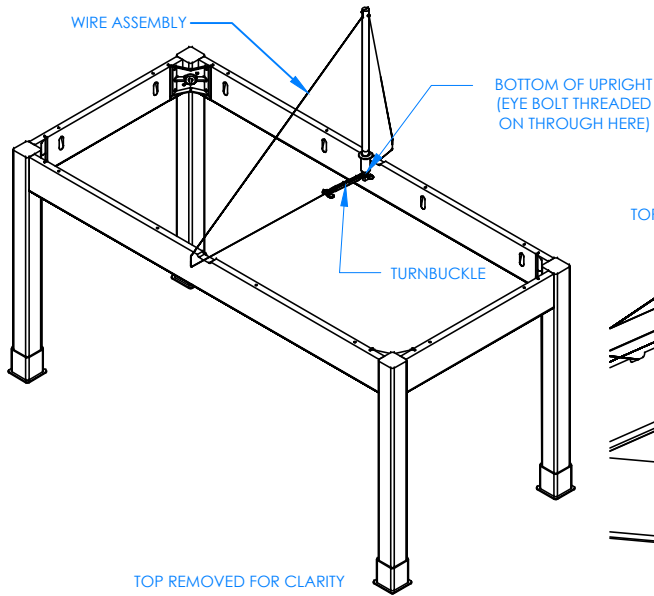

TOP REMOVED FOR CLARITY

STEP 5:

FROM THE BOTTOM SIDE OF TABLE, INSERT EYE BOLT (WITH HEX NUT THREADED ALL THE WAY ON), THROUGH FLAT WASHER, AND THREAD IT INTO THE BOTTOM OF THE UPRIGHT AND TIGHTEN. WITH TURNBUCKLE AND WIRE ASSEMBLY STRETCHED OUT, FEED THE END OF THE WIRE THAT IS FARTHEST AWAY FROM THE TURNBUCKLE UP THROUGH THE SLOT IN FRONT APRON (APRON THAT IS FARTHEST AWAY FROM THE ROD SOCKET). HOOK TURNBUCKLE ONTO THE EYE BOLT FOR THE TIME BEING AND PULL WIRE ALL THE WAY THROUGH THE FRONT NOTCH.

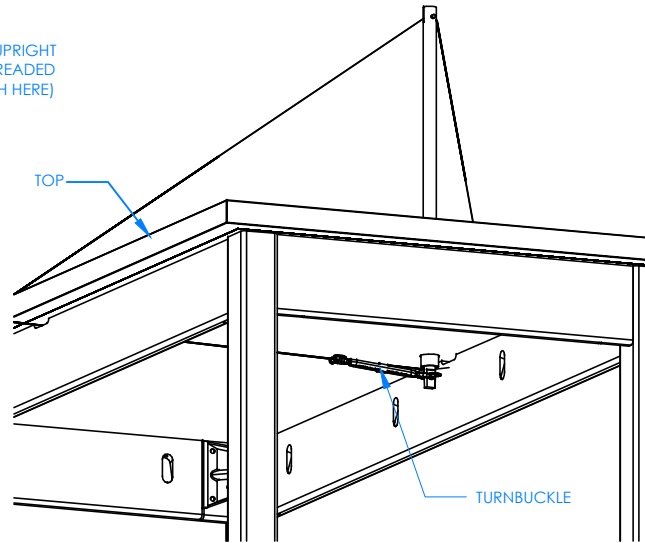

UNDERSIDE OF TABLE SHOWN HERE TO SHOWN TURNBUCKLE ASSEMBLY

STEP 6:

WRAP WIRE UP AND OVER THE TABLE, MAKING SURE THE WIRE FALLS INTO THE SLOT ON TOP OF THE ROD. CONTINUE TO WRAP THE WIRE DOWN THE BACK SIDE OF TABLE AND FEED THE LOOP END THROUGH THE SLOT OF BACK APRON. UNHOOK THE TURNBUCKLE FROM EYE BOLT. SLIP THE LOOP END OF THE WIRE OVER THE ROD SOCKET. RE-HOOK TURNBUCKLE TO THE EYE BOLT. START TURNING THE CENTER OF THE TURNBUCKLE TO START TENSIONING THE WIRE. WHEN FINISHED, TURNBUCKLE SHOULD BE VERTICAL WITH TABLE (SEE IMAGE AT BOTTOM).

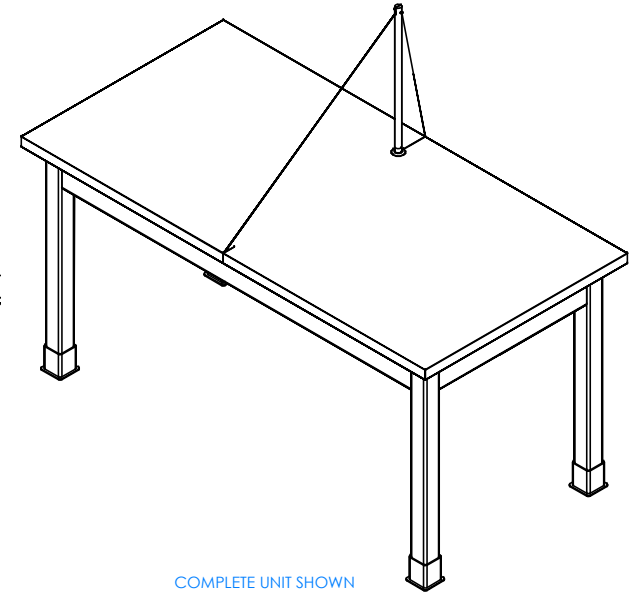

COMPLETE UNIT SHOWN

STEP 7:

APPLY CANVAS TOP COVER TO TOP. SET TABLE IN PLACE. NOTE: WASH CANVAS IN COLD WATER AND AIR DRY ONLY.



TURNBUCKLE ASSEMBLY

| | | | |
|---------|-----|-----------|--------|
| DWN BY: | EMK | DWN DATE: | 3/4/14 |
| APR BY: | | DATE APR: | |
| APR BY: | | DATE APR: | |



300 South Krueger Street
Suring, WI 54174
diversifiedwoodcrafts.com

UNLESS OTHERWISE SPECIFIED
DIMENSION ARE IN INCHES
CABINET SQUARENESS ± .0625
FRACTIONAL VALUES ± 1/32"
- ALL VALUES ± OVERALL -

TITLE:
CLAY WEDGING TABLE
ASSEMBLY INSTRUCTIONS

| REV. | DESCRIPTION | DATE | NAME | ECH NO. |
|------|-------------------------------|--------|------|---------|
| A | CREATED ASSEMBLY INSTRUCTIONS | 3/4/14 | EMK | - |

REVISION LEVEL

THIS DRAWING IS THE SOLE PROPERTY OF
DIVERSIFIED WOOD CRAFTS. IT MAY NOT
BE ALTERED OR CHANGED WITHOUT
PERMISSION

DRAWING NUMBER:

WT714

| | | |
|--------|--------|-----------|
| SCALE: | SHEET: | REVISION: |
| NTS | 4 OF 4 | REV A |