

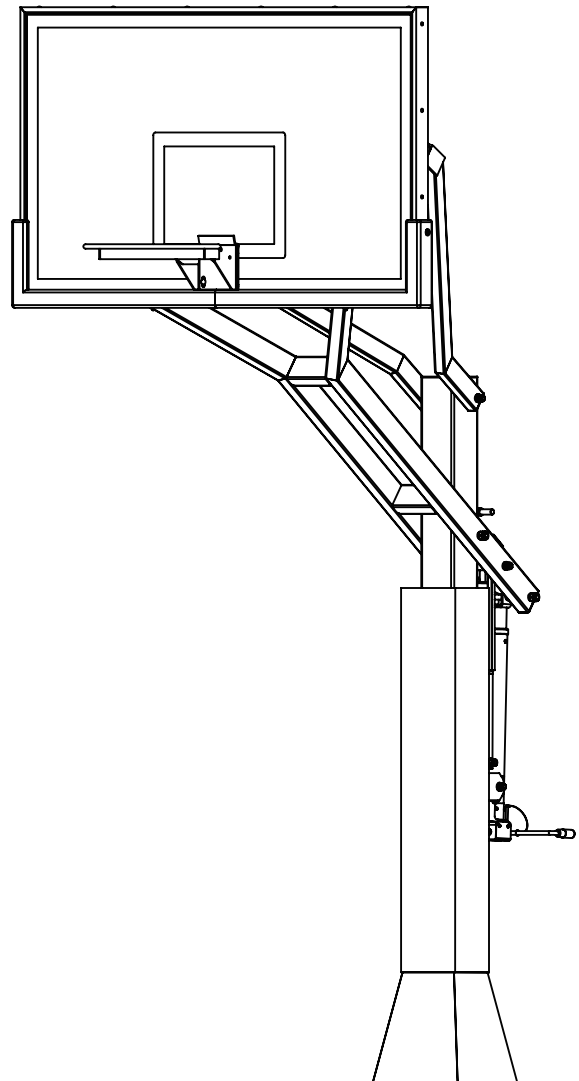

ADJUSTABLE BASKETBALL SYSTEM  
ASSEMBLY INSTRUCTIONS AND OWNER'S MANUAL

 **-PRO™ ADJUSTABLE  
SERIES**



**WARNING**



FAILURE TO COMPLY WITH ANY OF THE WARNINGS IN THESE INSTRUCTIONS MAY RESULT IN SERIOUS PERSONAL INJURY.

FAILURE TO COMPLY MAY ALSO RESULT IN PROPERTY DAMAGE. PLEASE HEED ALL WARNINGS AND CAUTIONS TO ENSURE YOUR SAFETY.

DO NOT ATTEMPT TO ASSEMBLE THIS SYSTEM WITHOUT CAREFULLY READING AND FOLLOWING ALL INSTRUCTIONS. BEGIN BY IDENTIFYING AND TAKING INVENTORY OF ALL PARTS USING THE PARTS LIST PROVIDED.

Douglas Industries, Inc.  
3441 South 11th Ave. -Eldridge, IA 52748  
Telephone: 1-800-553-8907  
[www.douglas-sports.com](http://www.douglas-sports.com)

Keep this instruction manual in case you have to contact the manufacturer for replacement parts.

TOOLS AND MATERIALS REQUIRED FOR ASSEMBLY  
(Not Included)

- |                            |   |
|----------------------------|---|
| 1. (2) Adjustable Wrenches | 10. Shovel  |
| 2. Socket Set              | 11. Concrete-1/2 yard or 14-16<br>Bags, (80 lb. bags) |
| 3. 3/4" Wrench             | 12. Phillips Head Screwdriver                         |
| 4. 5/8" Wrench             | 13. A minimum of (2) Ladders                          |
| 5. 1" Wrench               | 14. Carpenter's Level                                 |
| 6. 1-1/8" Wrench           | 15. Water Supply                                      |
| 7. 15/16" Wrench           |   |
| 8. Hammer or Mallet        |   |
| 9. Tape Measure            |   |

**\*\*A MINIMUM OF 3 - 4 ADULTS IS  
REQUIRED TO LIFT UNIT INTO PLACE\*\***

 STOP!

**BEFORE YOU START**

STOP! 

- A. Identify and inventory all parts using the checklist boxes in the parts list. Be sure to keep the hardware bags and their contents separate. If any parts are missing call our Customer Service Department (800-553-8907).
- B. Test fit all Bolts by inserting them into the respective hole. If necessary, carefully scrape away any excess powder coating buildup from inside the holes. Do not scrape away all of the powder coating. Bare metal may rust.



**SAFETY INSTRUCTIONS**



FAILURE TO FOLLOW THESE SAFETY INSTRUCTIONS MAY RESULT IN SERIOUS INJURY OR PROPERTY DAMAGE AND WILL VOID THE WARRANTY. The owner must ensure that all players know and follow these rules to safely operate the system. Proper and complete assembly, use and supervision is essential for proper operation and to reduce the risk of accident or injury. A high probability of serious injury exists if this system is not installed, maintained, or operated properly.

- If using a ladder during assembly, use extreme caution. Follow all warnings and cautions on the ladder carefully.
- 3-4 people are required to lift the unit into place.
- Before digging, contact the appropriate agency to locate underground power cables, gas, and water lines. Do not install the system within 20 feet of overhead power lines.
- Climate, corrosion, or misuse could result in system failure.
- If technical assistance is required, contact the manufacturer.
- Minimum operational height is 5' to the Rim. Most injuries are caused by misuse and /or failure to follow instructions. Use caution when using the system.

Verify all parts listed on packing list are present prior to installation. Contact our Customer Service at 1-800-553-8907 for assistance with replacement of any parts missing or damaged.

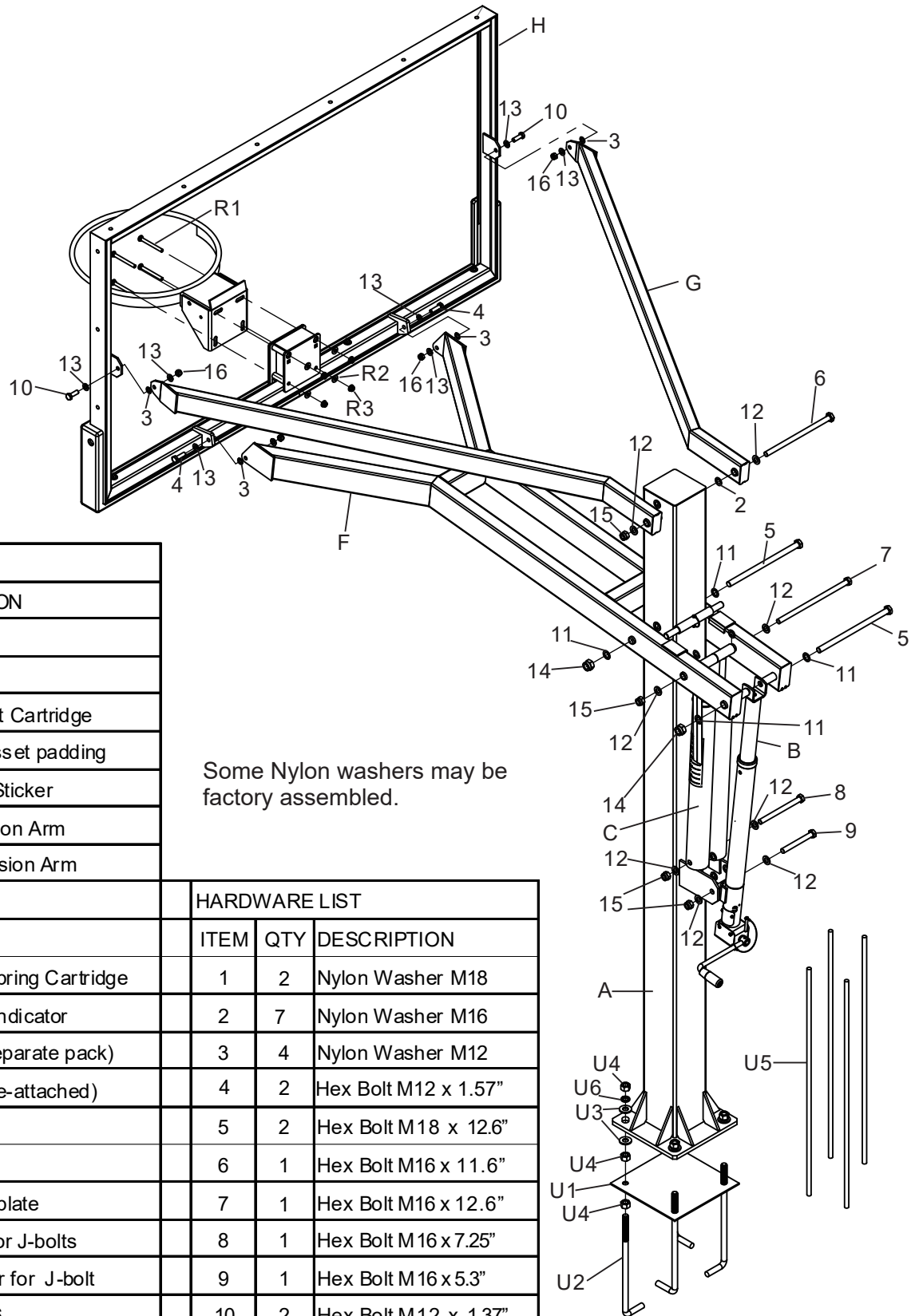

PARTS LIST		
ITEM	QTY	DESCRIPTION
A	1	Main Post
B	1	Actuator
C	2	Spring-Assist Cartridge
D	1	Pole and gusset padding
E	1	Rim Height Sticker
F	1	Main Extension Arm
G	2	Upper Extension Arm

Some Nylon washers may be factory assembled.

			HARDWARE LIST		
			ITEM	QTY	DESCRIPTION
H	1	Backboard			
J	1	Sleeve for Spring Cartridge	1	2	Nylon Washer M18
K	1	Rim Height Indicator	2	7	Nylon Washer M16
L	1	Flex Rim (Separate pack)	3	4	Nylon Washer M12
M	1	Rim Pad (Pre-attached)	4	2	Hex Bolt M12 x 1.57"
			5	2	Hex Bolt M18 x 12.6"
UNDERGROUND PARTS			6	1	Hex Bolt M16 x 11.6"
U1	1	Anchor Template	7	1	Hex Bolt M16 x 12.6"
U2	4	16mm Anchor J-bolts	8	1	Hex Bolt M16 x 7.25"
U3	8	Thick washer for J-bolt	9	1	Hex Bolt M16 x 5.3"
U4	12	Hex nut M16	10	2	Hex Bolt M12 x 1.37"
U5	4	Anchor Rebar 36"L	11	4	Washer for M18 Bolt
U6	4	Lock Washer M16	12	8	Washer for M16 Bolt
RIM HARDWARE			13	8	Washer for M12 Bolt
R1	4	Carriage bolt M10x110mm	14	2	Lock Nut M18
R2	4	Washer M10	15	4	Lock Nut M16
R3	4	Flange nut M10	16	4	Lock Nut M12



**Know what's below.  
Call 811 before you dig.**

One, free easy call gets your utility lines marked  
AND helps protect you from injury and expense

**Utility Markings**

Color	Definition
Red	Electric
Yellow	Gas, Oil, Petroleum
Orange	Communication, Phone, TV
Blue	Portable Water, Irrigation
Green/Brown	Sewer
White	Proposed Dig

NOTE: At rim height 10', distance from the face of backboard to the front of Main Post(A) is 48" , Choose the proper location to dig for the concrete footing:

**STEP A**

- a. Dig a hole 48" deep and 20"x 20"square . The edge of the hole should be flush with the edge of the playing surface. If you live in an area where heavy frost can occur, it may pose a problem, consult your local building inspector to determine the appropriate hole depth.

NOTE: The hole must be at least 48" deep.

- b. Build a form before pouring the concrete pad, to ensure that the top of the concrete remains straight and square. The form should be placed about 1/2" above the playing surface to allow for water drainage.
- c. Bell out the bottom of the hole.

NOTE: A square hole prevents the rotation of the concrete.

NOTE: The area behind the playing surface must be cleared off by at least 3 feet to enable the user to stand behind the pole to adjust the Rim height.

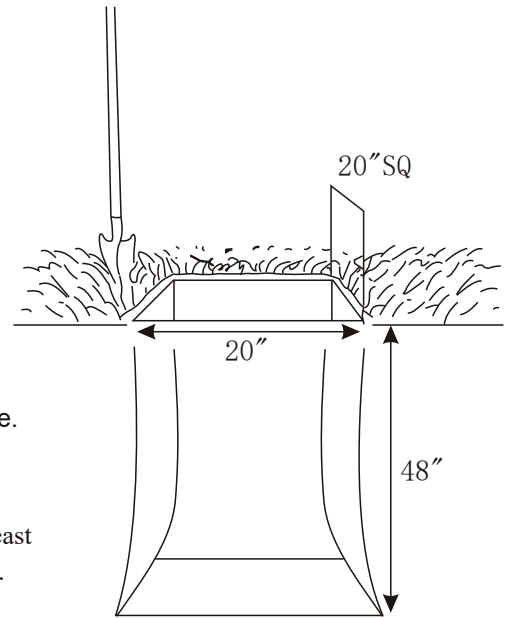

**STEP B**

- A. Thread a 16mm Hex Nut (U4) onto each of the 16mm J-Bolts (U2). Securely tighten the Nuts all the way down to the end of the threads.
- B. Slide the threaded end of the J-Bolts through the holes in the Anchor Template (U1) and secure each J-Bolt with a 16mm J-Bolt Hex Nuts (U4) as shown. Securely tighten all Nuts at this time.

NOTE: Make sure the curved "J" ends of the J-Bolts are oriented in a rectangular pattern, as shown.

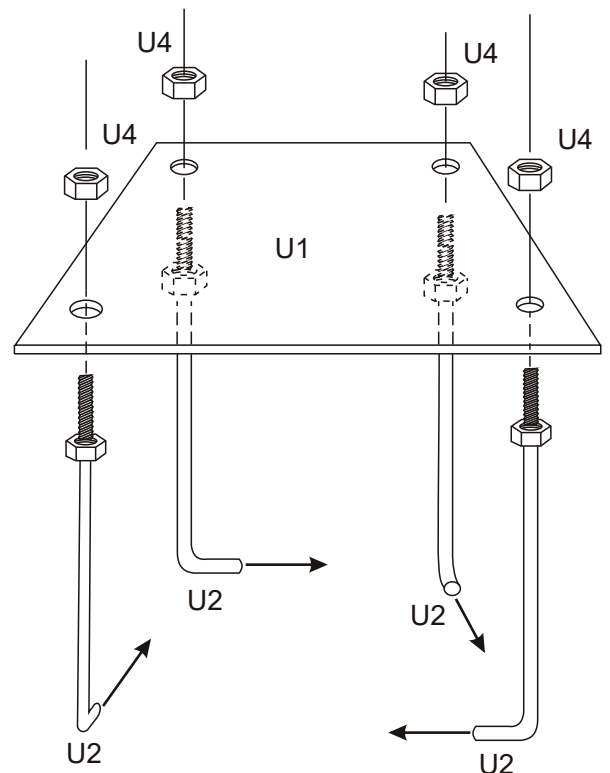
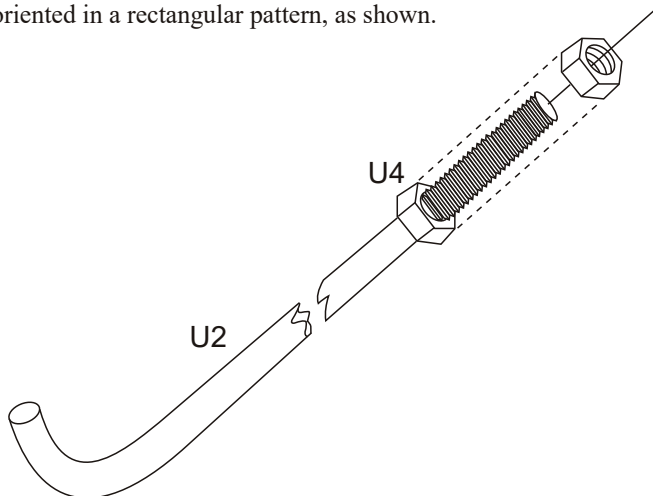

## STEP C

- Mix the concrete according to the instructions on the bags. Note that a thicker mix of concrete will dry stronger than a thin mix. Pour the concrete into the hole, stopping approximately 18 inches from the top of the hole.
- Insert the four pieces of Anchor Rebar (U5) into the hole, pushing each piece firmly to the bottom of the hole. The four pieces should be arranged in a square approximately 8 inches wide so that each piece of rebar will be positioned next to the J-Bolts when the J-Bolt Template is placed in the cement.
- Finish filling the hole to the top with concrete. The top of the concrete should reach just above the level of the top of the form.

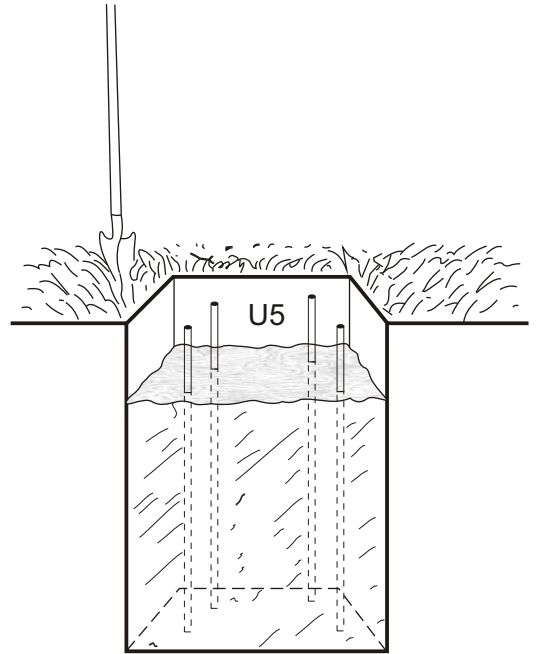

## STEP D

- Position the J-Bolt Template (U1) over the hole so that it is centered, with the sides of the plate square with the sides of the hole.
- Push the J-Bolts (U2) into the concrete until the J-Bolt Template is resting flat against the surface of the concrete.
- Grasp the tops of the J-Bolts and agitate the Template assembly back and forth repeatedly to eliminate any air bubbles in the concrete. Lift the Template slightly above the concrete when agitating. Make sure the Template is resting on the concrete after agitating. Form the concrete into a downward slope away from the Pole to allow water runoff.
- Clean off any concrete that may be on the J-Bolt Template or the exposed portions of the J-Bolts.
- Using a carpenter's level, make sure the Template is square to and level with the playing surface.
- Allow the concrete to cure for a minimum of 5-7 days before installing the rest of your basketball system. In cold, wet weather or humid climates, allow additional time for the concrete to cure.

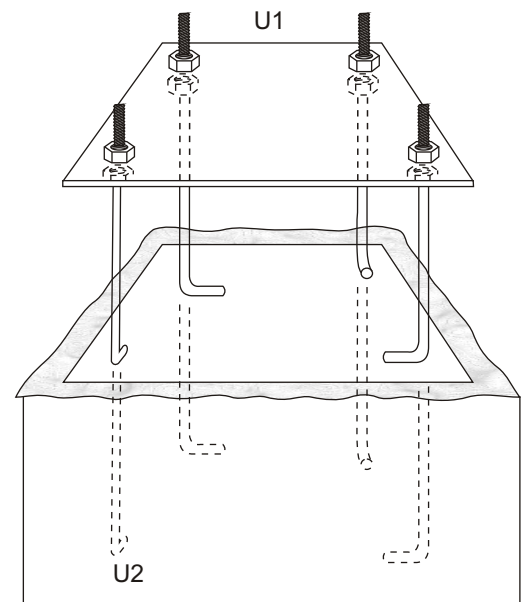

**YOU ARE NOW FINISHED WITH THE INITIAL ASSEMBLY STEPS. DO NOT PROCEED WITH THE ASSEMBLY UNTIL THE CONCRETE HAS FULLY CURED. CURING WILL TAKE A MINIMUM OF 72 HOURS. IN HUMID CLIMATES OR WET WEATHER, ALLOW ADDITIONAL TIME FOR THE CONCRETE TO CURE.**



## WARNING



NEVER USE THE SYSTEM WITHOUT FOLLOWING THE CEMENTING INSTRUCTIONS. FAILURE TO FOLLOW ALL OF THESE INSTRUCTIONS AND WARNINGS COULD LEAD TO SERIOUS PERSONAL INJURY OR PROPERTY DAMAGE AS LISTED ON PAGE ONE.



# WARNING



**\*BECAUSE OF THE SIZE AND WEIGHT OF THE SYSTEM, A MINIMUM OF THREE ADULTS ARE REQUIRED FOR THE FOLLOWING STEPS\***

## STEP1

- A. Slide a 16mm Thick Washer (U3) over each of the J-Bolts (U2) as shown in FIGURE 1A.
- B. Remove the Padding from Main Post (A). Place the Main Post (A) over the J-Bolts. Slide a 16mm Thick Washer (U3), a Lock washer 16mm (U6) and thread a 16mm Hex Nut (U4) to each J-bolt. Tighten the Nuts only a few turns onto the J-Bolts as shown in FIGURE 1B.
- C. If the Main Post (A) is not exactly vertical, adjust the 16mm J-Bolt Hex Nuts (U4) located under the Post base. Tighten all of the Hex Nuts (U4) Above Post base when Main Post (A) is vertical.

*NOTE: Face the Main Post (A) with Actuator Bracket facing away from playing court (as shown in FIGURE 1C).*

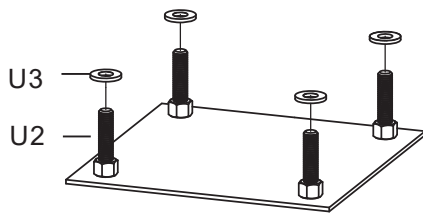

FIGURE 1A

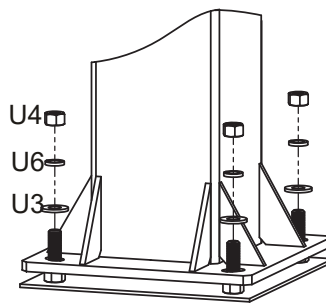

FIGURE 1B

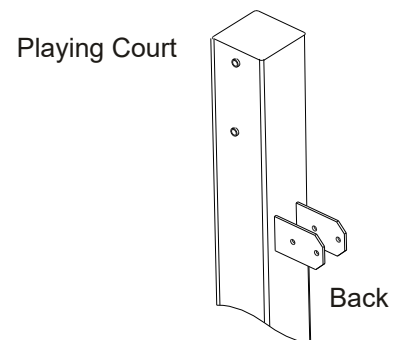

FIGURE 1C

Nylon washer #1 may be factory installed

## STEP2

- A. Slide the Main Extension Arm (F) over the top of the Main Post (A) and attach to the lower pivot tube (which goes through the pole) with a M18 x 12.6" Hex Bolt (#5), two M18 Flat Washers (#11), two Nylon Washers M18 (#1) and one Lock nut M18 (#14).

Do not over tighten this bolt and nut.

*Note: make sure Nylon washers locate between Main Extension Arm (F) and Post (A).*

*The Nylon washers may be factory-assembled.*

- B. Install stop pin through designated hole and secure with ring

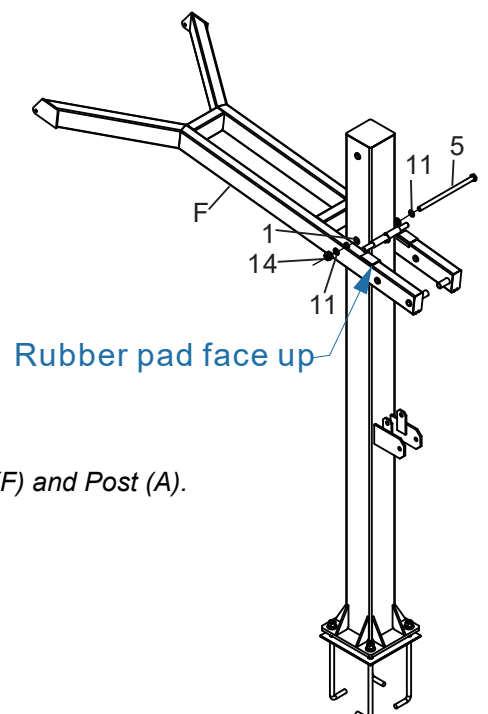

### STEP 3

- A. **Connect Actuator to Main Extension arm.**  
Place the upper bracket of Actuator(B) between the last set of welded tubes on the Main Extension Arm (F), attach the two parts using Hex bolt M18 x 12.6" (#5), two Flat Washers M18 (#11), one Lock nut (#14).
- B. **Connect Actuator(B) to the mounting bracket welded in the middle of Post (A),** using one Hex Bolt M16 x 5.3" (#9), two flat Washers for M16 Bolt (#12), two Nylon Washers (#2), and one Lock Nut for M16 bolt (#15).

*Note: make sure Nylon washers go between Actuator and Mounting Bracket.*

- C. **Attached Crank handle to the actuator.** Slide Removable Crank handle onto the shaft sticking out of Gear Box (Actuator), lock it in place with attached pin.

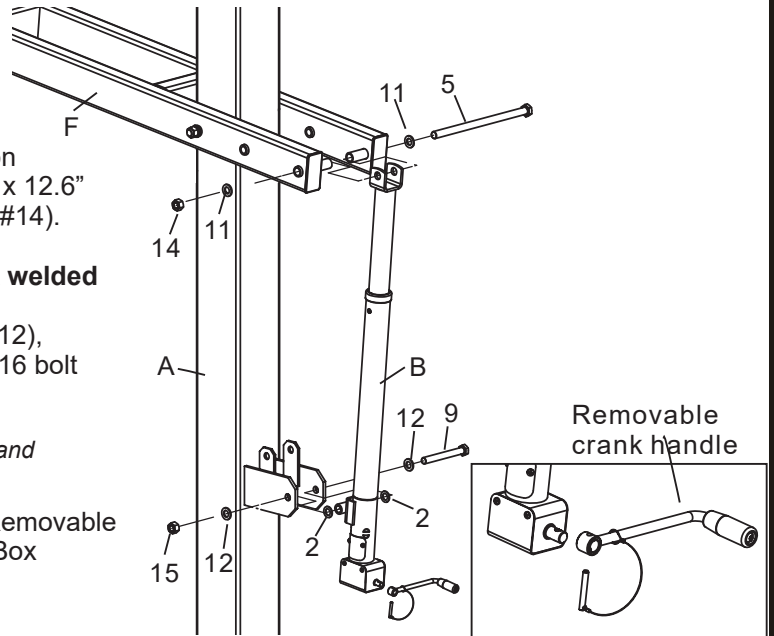

### STEP 4

- A. Slide Steel Sleeve (J) thru both tubes welded at the top end of Spring-Assist Cartridge (C). Place the top of Spring-Assist between Main extension (F), align the Steel Sleeve (J) with the second set of welded tubes on the Main Extension Arm (F), place the Stainless steel Rim Height Indicator (K) beside the Spring-Assist Cartridge (C). Slide one Washer M16 (#12) over one Hex Bolt M16 x 12.6" (#7), and slide this Bolt all the way thru Main Extension Arm (F), one Nylon washer M16(#2), Steel Sleeve (J), Rim Height indicator (K), another Nylon washer (#2), and the other side of Main Extension Arm (F). Secure it with one Flat Washer M16 (#12), one Lock nut M16 (#15). Do not over tighten this bolt because this is the pivot point. Make sure the Rim Height Indicator(K) hang freely along side of Spring-Assist Cartridge (C).

*Nylon washer locates between Steel sleeves (J) and Main Extension Arm (F). They may be factory-assembled already.*

- B. Attach the bottom of Spring-assist Cartridges (C) to the Main post Bracket by using a Hex Bolt M16 x 7.25" (#8), two Flat Washers M16 (#12), one Nylon Washer M16 (#2) and one Hex Nut M16 (#15).

*Note: Nylon washer goes between two Cartridges.*

- C. Remove and discard the Steel spreader bracket from the Spring-Assist Cartridges.

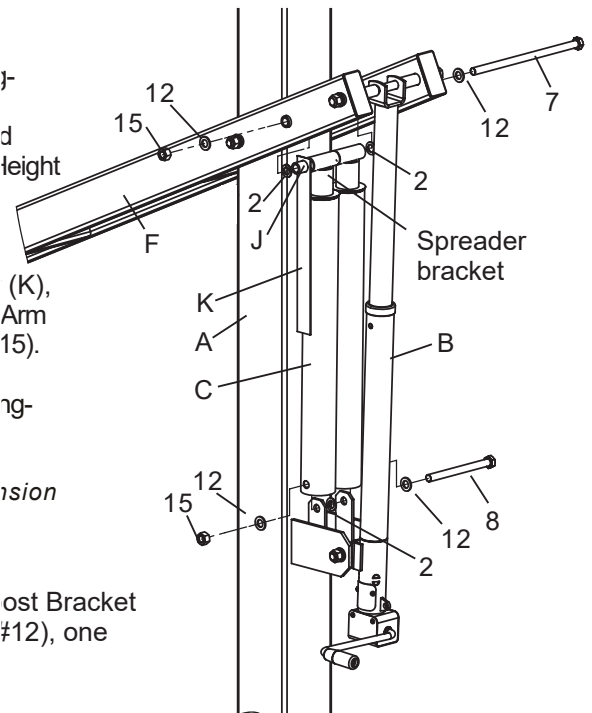

### STEP 5

- A. Attach the Two Upper Extension Arms (G) to Main Post (A) with one Hex Bolt M16 x 11.6" (#6), two Flat Washers M16 (#12), two Nylon washers M16 (#2) and one Lock nut M16 (#15)

*Note: the Nylon washers go between Upper extension arm and Main Post.*

*Do not tighten at this time.*

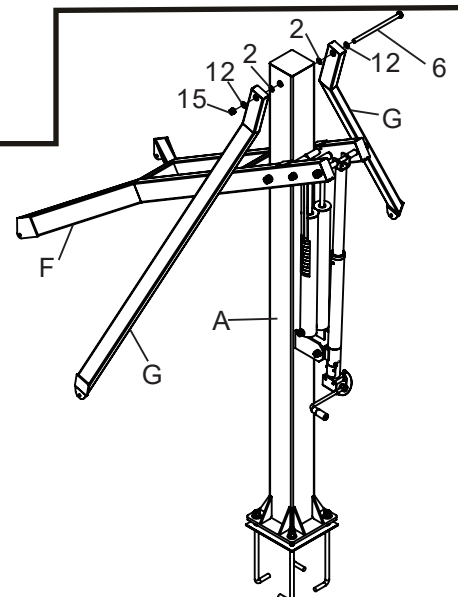



## STEP 6

Crank the Main extension arm as low as possible.

- A. Attach the Backboard to Main Extension Arm (F)** by using two Hex Bolt M12 x 1.57" (#4), four M12 Flat Washers(#13), two Nylon washers (#3) and one Lock Nut M12 (#16).

*Note: Nylon washers go between Main extension arm Bracket (F) and Backboard mounting bracket.*

- B. Connect Upper Extension Arms (G) to Backboard (H),** using 2 Hex bolts M12 x 1.37" (#10), 4 Flat Washers M12 (#13), 2 Nylon washers M12 (#3) and 2 Lock nuts M12 (#16).

*Note: Put Nylon washers between backboard plate and Upper extension connecting plate.*

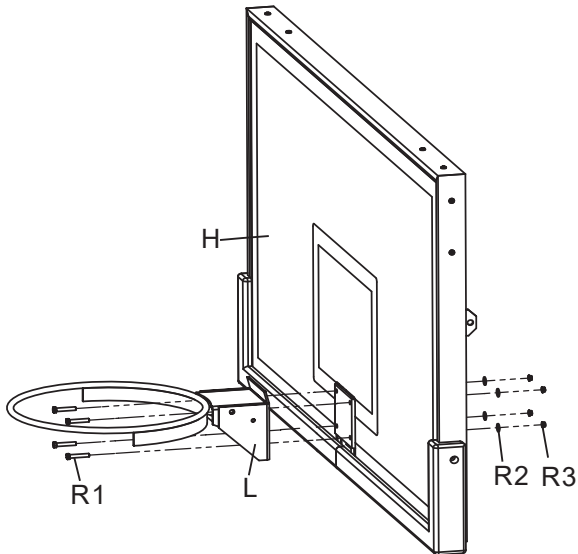
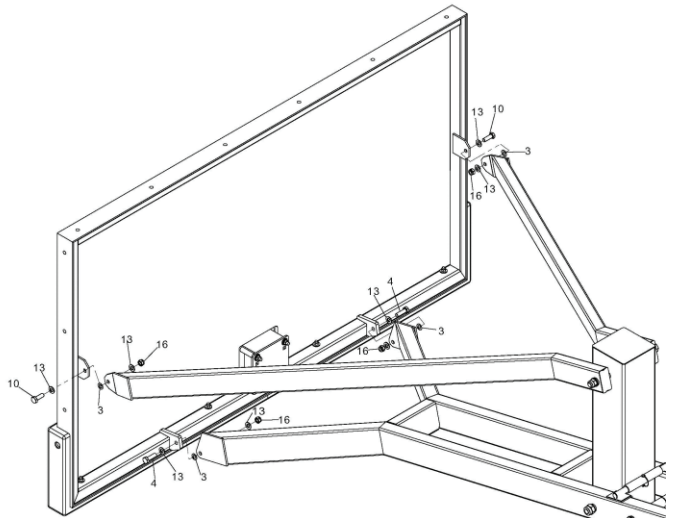

## STEP 7

- A.** Remove the screws on Rim spring box cover, open the Spring box.  
*(Rim Spring Box cover may not be factory-assembled.)*
- B.** Mount the rim to the Mounting bracket on Backboard (H) using the hardware supplied in rim box.
- C.** Re-attach Spring box cover to the Rim with removed screws.

*NOTE: Use a level to make sure rim is level side to side before tightening nuts.*

## STEP 8

- A.** After everything is square, make sure all nuts on the system have been tightened.

*NOTE: But do not over tighten the Nuts, make sure the unit can be adjusted up and down.*

- B.** To apply the Rim Height Sticker(In the manual pack), first use a tape measure to crank rim up to exactly 10' from the playing surface. Use a pencil to make a mark on the Spring-assist Cartridge(C) where the bottom of the Rim Height Indicator(K) stops. Then, peel and apply Rim Height Sticker to outside of Spring-assist Cartridge(C) lining up the pencil mark with the 10' mark on the Rim Height Sticker. See detail A.

- C.** Attach Post Pad and Gusset Pad to Main Post(A) as shown.

