

Installation Instructions

8'-10' Basketball Backstop Height Adjuster by Draper

Caution

- ① Locate and identify all pieces. Please note that clamps are packed separately from main unit.
- ② Do not paint inner slip tubes.
- ③ DO NOT use portable electric winch operator or electric drill to operate manual Height Adjusters.
- ④ For manual units, apply entire tube of lubricant (included) to T-Nut after installing threaded rod assembly.
- ⑤ For electric operators, make sure Actuator Tube is vertically plumb.
- ⑥ Electric Height Adjuster operates on 110-120V, 60-Hz current.
- ⑦ Make sure power is disconnected before wiring electric Height Adjuster.

Attaching to Backstop

- ① If not already attached, bolt any necessary attachment brackets to the height adjuster mounting tubes (see Fig. 1). If height adjuster is attaching to a T-Stem, the saddle portion of the clamp goes over the height adjuster mounting tube so that the tube rests between the saddle and mast. The saddle is held in place by the U-bolt. Nuts that attach to the U-bolts and saddle brackets should be tightened to 85 ft.-lbs. On T-Stem backstops, after the height adjuster is secured in the correct position, drill the mast tube just below the bottom U-bolt and install a $\frac{3}{8}$ "-16 x 1" self-tapping safety screw (see Fig. 2).

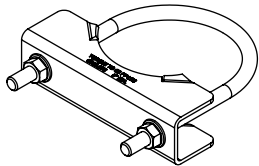

Clamp Attachment for T-Stem Units

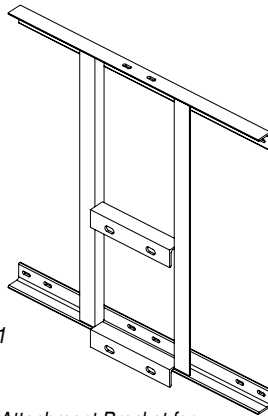
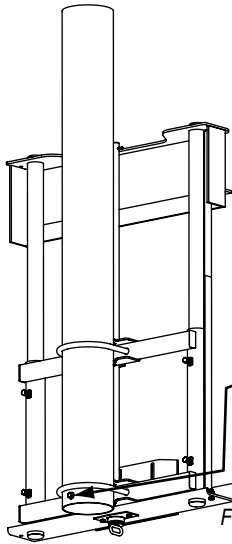

Figure 1

Attachment Bracket for Wall Mount and Double Drop Units



After drilling through Tube, thread a $\frac{3}{8}$ "-16 x 1" long bolt through hole below bottom U-Bolt. Bolts are provided with Height Adjuster.

Figure 2

Manual Height Adjuster Assembly

(May be partially assembled at factory)

- ① Attach Nut Carrier and T-Nut to Height Adjuster.
- ② Install Threaded Rod Assembly through the bearing assembly, lower height adjuster plate and T-Nut (see Fig. 3).

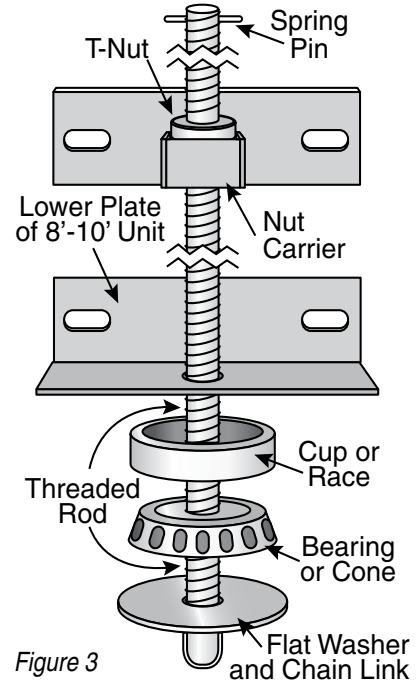

Figure 3

- ③ Apply *entire tube* of lubricant (included) just above and below the T-Nut. As the threaded rod operates through the T-Nut, the lubricant will be spread onto the threaded rod as necessary.

Please Note: Be sure to apply the *entire tube* as described. If the lubricant is missing from your package, contact Draper, Inc.

- ④ Thread nylon bolts into rear mainframe assembly until they just touch the slip tubes. Tighten down nylon jam nuts to secure.
- ⑤ Test operation.

Electric Height Adjuster Assembly

- ① Locate appropriate Actuator Brackets (see Figure 4), and attach to specific backstop frame.
- ② Bolt Electric Actuator to Upper Actuator Bracket.
- ③ Attach Actuator Tube to Lower Actuator Bracket.
- ④ Wire according to wiring diagram.

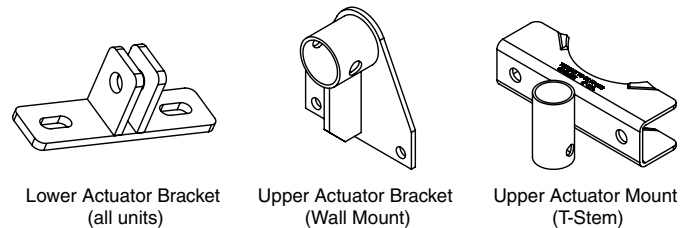

Figure 4

Please Note: Be sure power is disconnected before wiring Height Adjuster.

- ⑤ Verify that Height Adjuster has at least 24" of travel, and that the full "up" position places the goal at 10' above floor. Adjust limit switches as necessary (see "Adjusting Limit Switches" below).
- ⑥ Thread Nylon Bolts into rear mainframe assembly until they just touch the slip tubes. Tighten down nylon jam nuts to secure.

DRAPER

Adjusting Limit Switches

- ① The upper (raised) position is pre-set at the factory.
- ② The upper plastic ring (A) controls the "down" position. Should this need to be adjusted, simply rotate clockwise for more travel and counterclockwise for less travel (see Fig. 5).

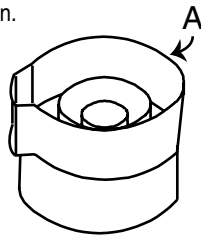

Figure 5

Please Note: The inner tube must be turned out three full turns (1/2") for safe, repeatable operation. It can be turned out more if required by application and if the upper cam is adjusted properly to prevent driving the inner tube against the full extend positive stop.

Attaching Bank Lift Angle & Backboard to Height Adjuster

- ① Locate Bank Lift Angle from the appropriate backboard kit. These will be used to attach the Height Adjuster to the upper mounting holes of the backboard.
- Note: See remaining sections for individual backboards that require the use of special configurations/spacers to be attached before attaching the Lift Angle and/or Backboard.
- ② Bolt Lift Angle to the Height Adjuster.
 - ③ Bolt backboard to completed Height Adjuster.
 - ④ Position Rim to exactly 10' above floor and attach to Scale Mounting Bracket. Bracket pins at the top and bolts to the lower height adjuster plate. Cut a small (1/2" wide) section off of bottom of self-adhesive height indicator scale, then apply self-adhesive height indicator scale.

42" Glass Backboard Spacer Only

- ① Locate 42" Glass Bank Spacer Assembly (see Fig. 6). Only 42" Glass Backboards require this unique spacer between the board and the Height Adjuster.
- ② Attach the 42" Glass Bank Spacer to the Backboard using the bottom holes. Backboard with spacer then attaches to Height Adjuster through top holes when goal is bolted in place.

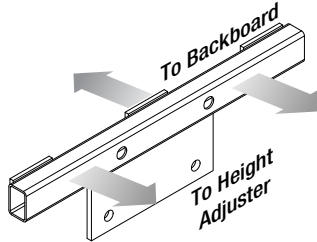

Figure 6

48" Rectangular Bank Spacers

- ① Locate Lift Angle Spacers from the board mounting kit (see Fig. 7).
- Note: All 48" rectangular boards require two Lift Angle Spacers.**
- ② 48" Glass boards require two more spacers at the goal mount in addition to the Lift Angle spacers. If installing 48" Glass bank, locate 7" Glass Bank Spacers.
 - ③ Place Lift Angle Spacers under Lift Angle and bolt through spacer when installing the Lift Angle.
 - ④ Place 7" Glass Bank Spacers between the Height Adjuster's goal mounting plate and the Glass Backboard. Bolt through the spacers for direct goal attachment.

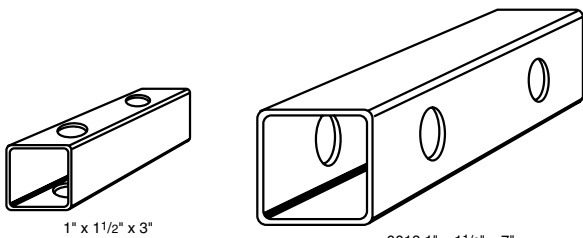

Figure 7

Fan Aluminum Bank Spacers

- ① Locate Lift Angle from the board mounting kit (see Fig. 8).
- ② Bolt Lift Angle to Height Adjuster with the Angle turned down.
- ③ Locate Fan Aluminum Goal Spacer from the board mounting kit.
- ④ Place Goal Spacer between the Backboard and the Height Adjuster, positioning it between the Goal Mounting Bolts.
- ⑤ Apply the 1/2" wide section cut of stationary outer slip tube so that it lines up with 10' marking.

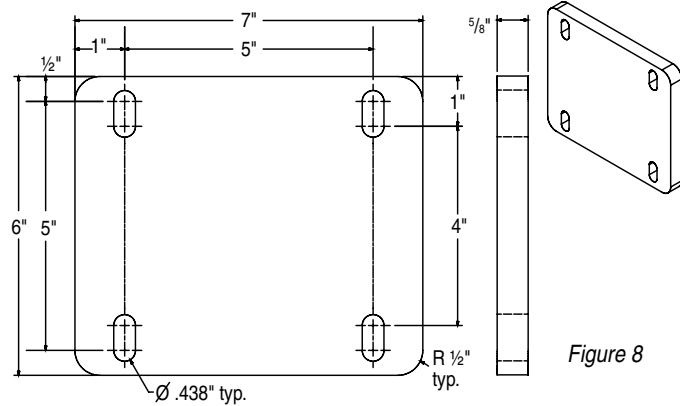
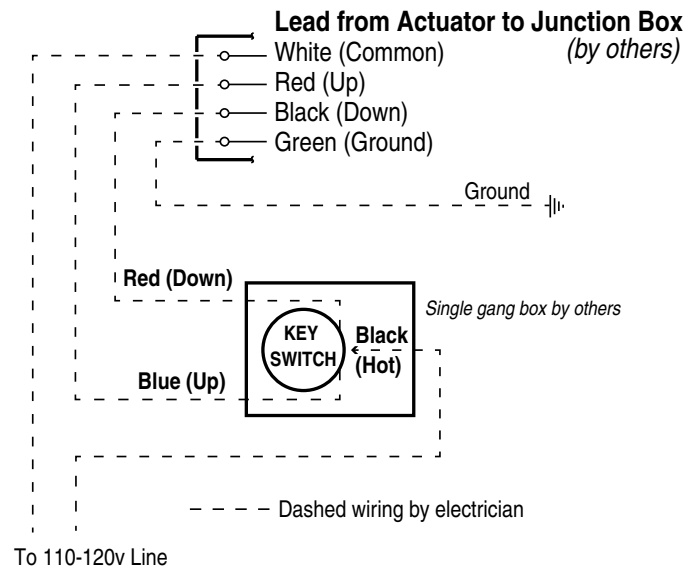

Figure 8

Fan Glass/Fiberglass Lift Angle

- ① Locate Lift Angle from the board mounting kit.
- ② Bolt Lift Angle to Height Adjuster with the Angle turned up.

Wiring Diagram



Draper Key Switch

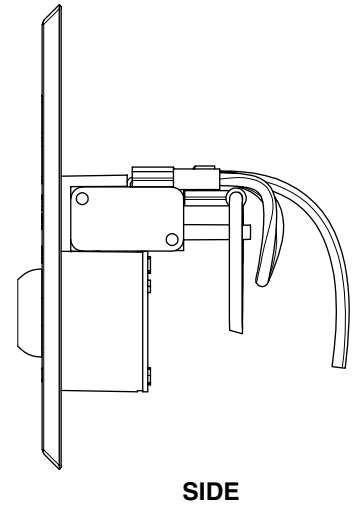
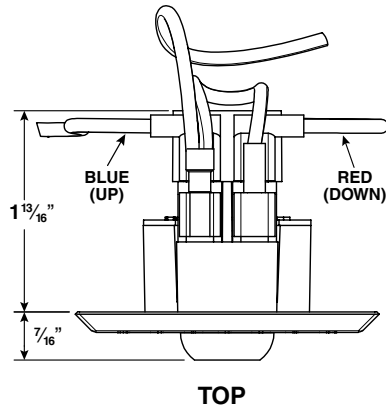
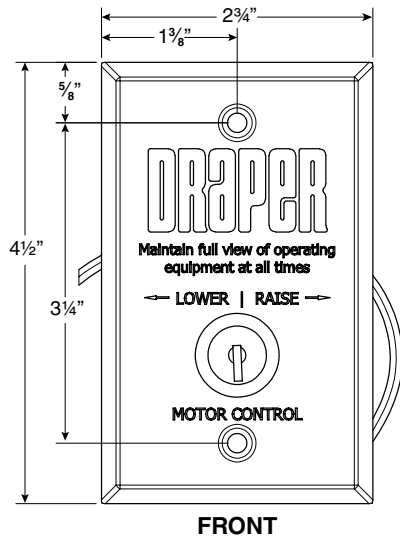

Assembled Height Adjusters

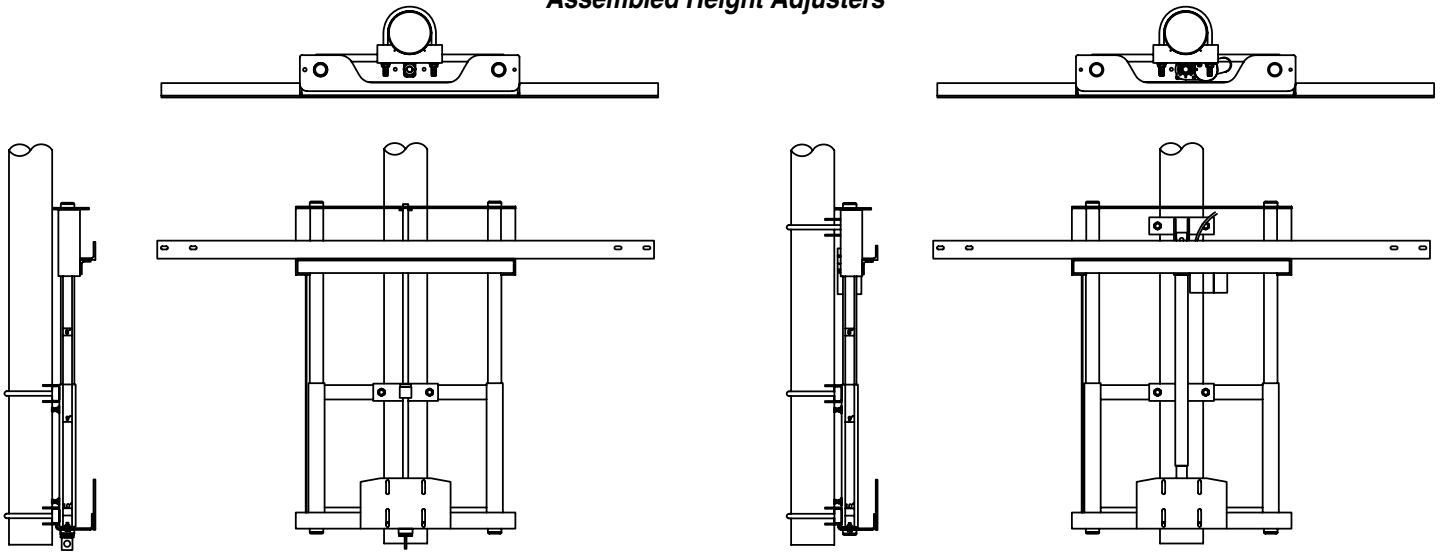

Rectangular Bank Manual Height Adjuster

Rectangular Bank Motorized Height Adjuster

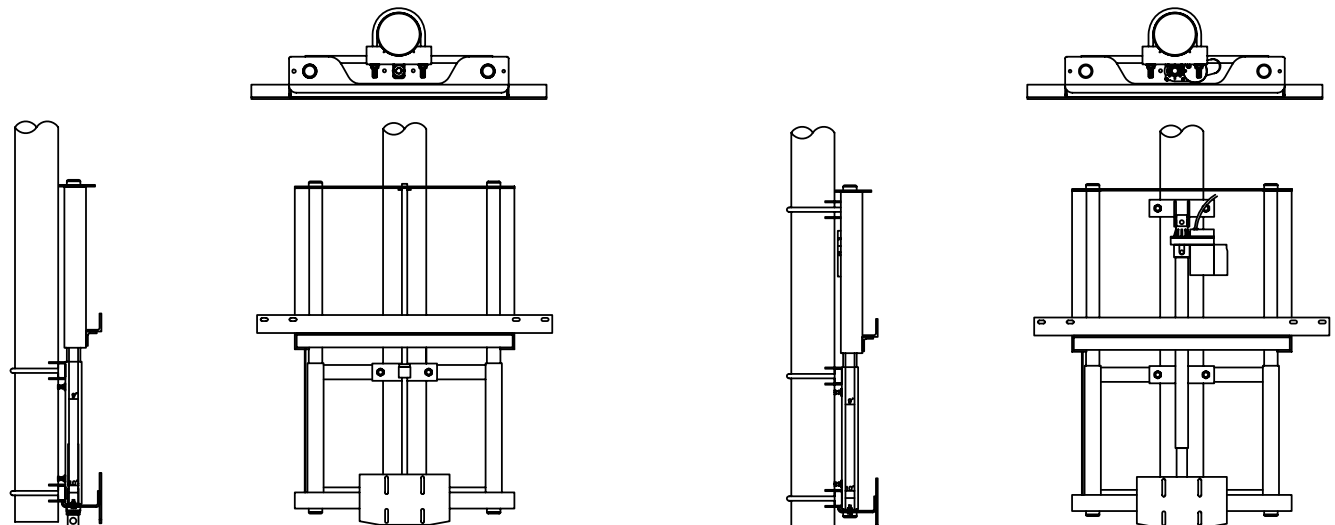

Fan Bank Manual Height Adjuster

Fan Bank Motorized Height Adjuster