

YAKIMA BowDown

US

MINIMUM CROSSBAR SPREAD 24" (61CM)

FOR FACTORY RACKS: Check fitlist notes, or Yakima.com for your vehicle's crossbar spread.

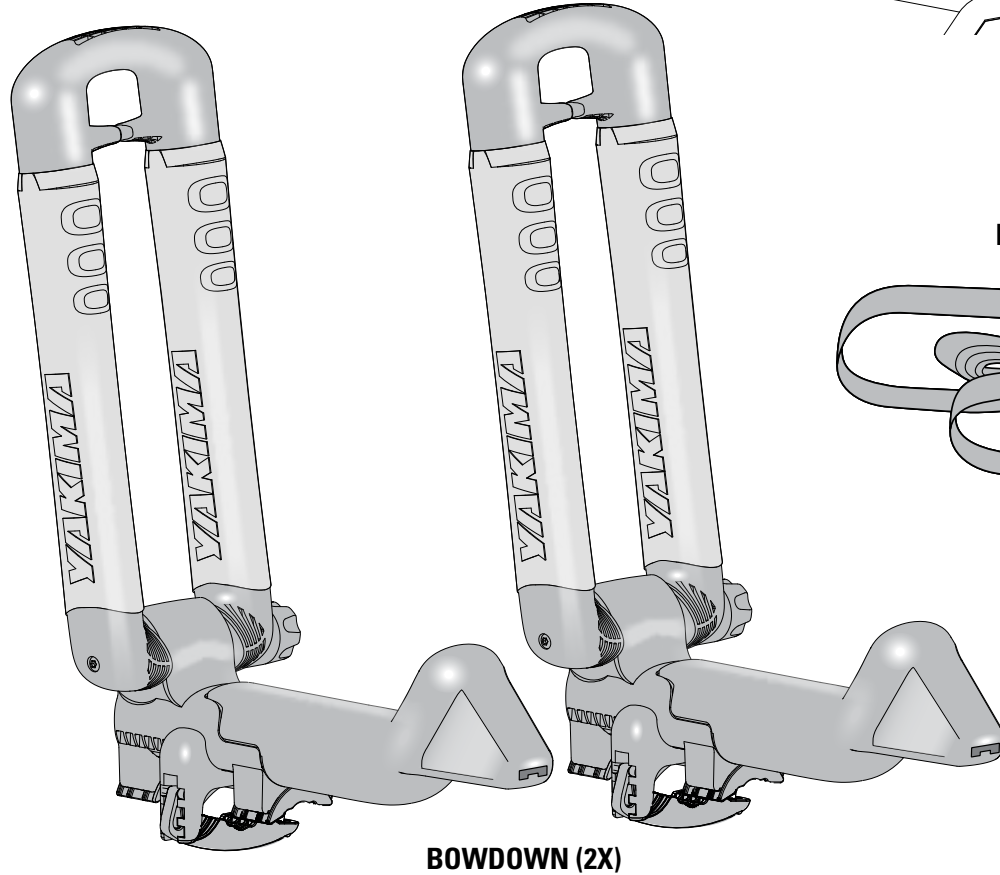
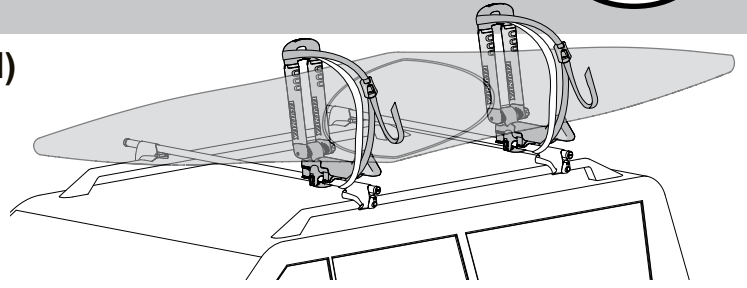

HEAVY DUTY STRAP (2X)

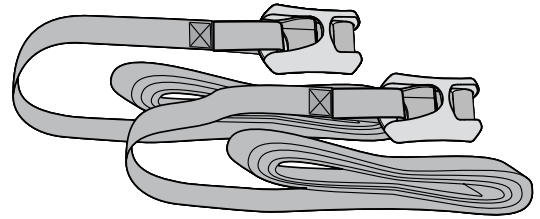

SHORT BLACK T-BOLT (2X)

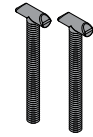

BOWDOWN (2X)

BOW STERN TIE DOWN

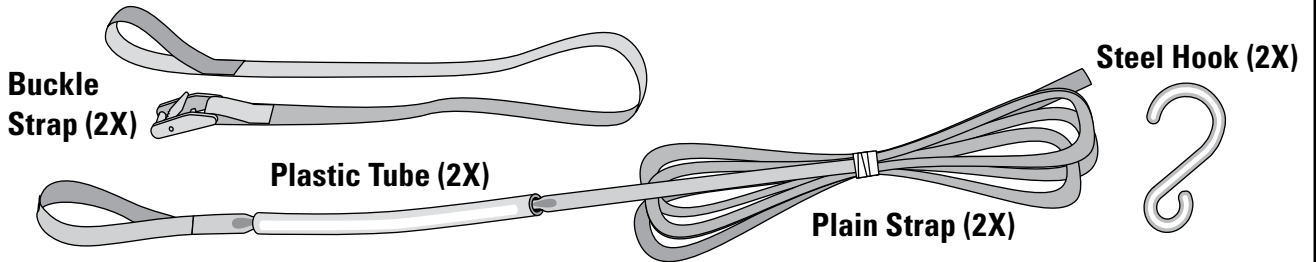

IMPORTANT WARNING

IT IS CRITICAL THAT ALL YAKIMA RACKS AND ACCESSORIES BE PROPERLY AND SECURELY ATTACHED TO YOUR VEHICLE. IMPROPER ATTACHMENT COULD RESULT IN AN AUTOMOBILE ACCIDENT, AND COULD CAUSE SERIOUS BODILY INJURY OR DEATH TO YOU OR TO OTHERS. YOU ARE RESPONSIBLE FOR SECURING THE RACKS AND ACCESSORIES TO YOUR CAR, CHECKING THE ATTACHMENTS PRIOR TO USE, AND PERIODICALLY INSPECTING THE PRODUCTS FOR ADJUSTMENT, WEAR, AND DAMAGE. THEREFORE, YOU MUST READ AND UNDERSTAND ALL OF THE INSTRUCTIONS AND CAUTIONS SUPPLIED WITH YOUR YAKIMA PRODUCT PRIOR TO INSTALLATION OR USE. IF YOU DO NOT UNDERSTAND ALL OF THE INSTRUCTIONS AND CAUTIONS, OR IF YOU HAVE NO MECHANICAL EXPERIENCE AND ARE NOT THOROUGHLY FAMILIAR WITH THE INSTALLATION PROCEDURES, YOU SHOULD HAVE THE PRODUCT INSTALLED BY A PROFESSIONAL INSTALLER.

PREPARE FOR INSTALLATION

1

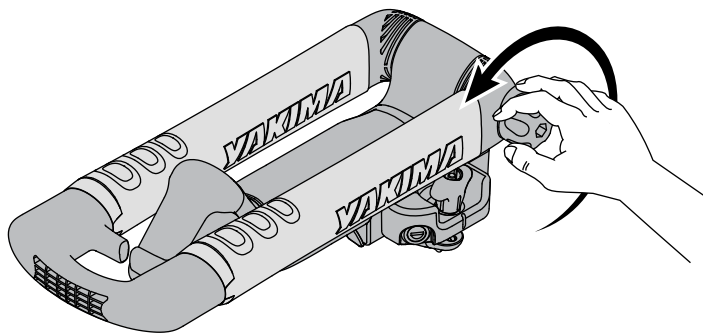

Loosen the knob 6 to 8 turns. Do not remove knob.

2

Raise BowDown up, then tighten the knob with firm pressure.

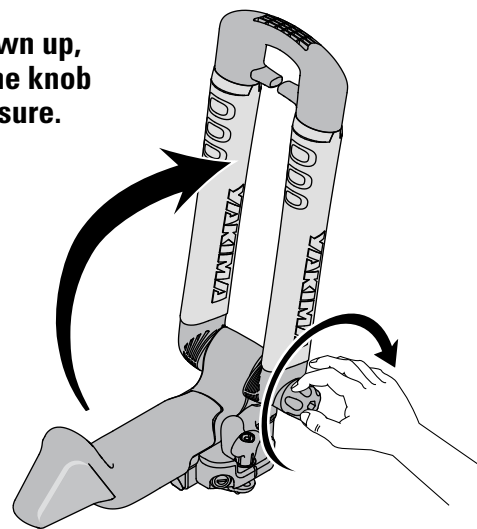

3 ADJUST BAIL POSITION (IF NECESSARY)

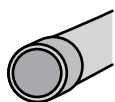

Middle notch for round bars.

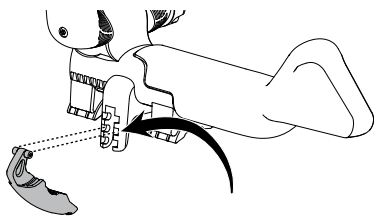

ROUND BAR

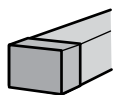

Upper notch for square bars.

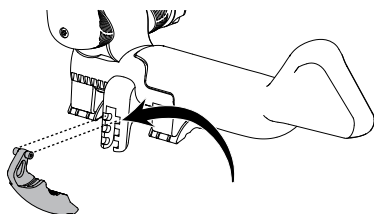

SQUARE BAR

FACTORY BAR ONLY

Choose best position for most secure grip.

NOTE: Some smaller factory bars may require the short, black T-bolts included with this product.

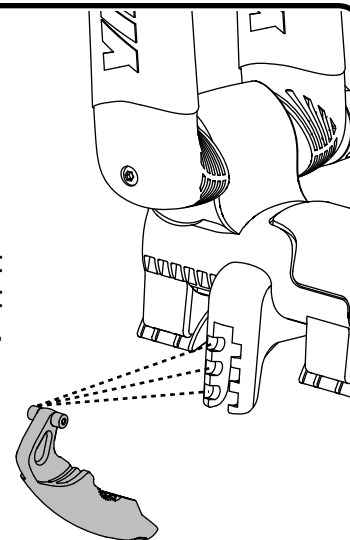

INSTALL BOWDOWN

4 POSITION BOWDOWN ON VEHICLE

Position BowDown on the crossbar.

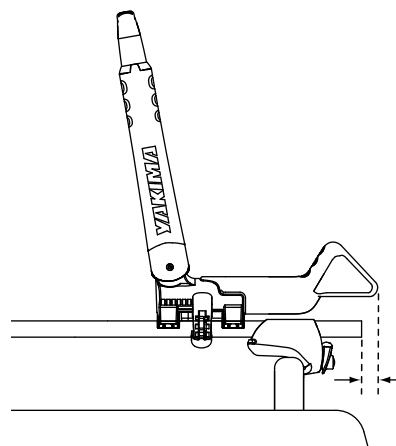
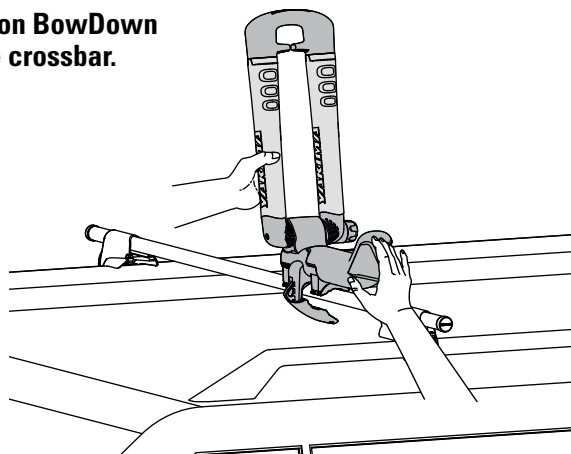

Position the tip of BowDown so that it protrudes slightly further than the crossbars.

5 SET BOWDOWN TO BE VERTICAL

BowDown should be as close to vertical as possible. If necessary adjust mounts.

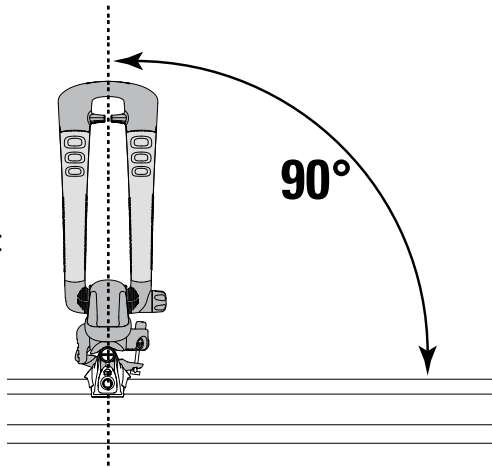

If necessary adjust the waffle blocks.

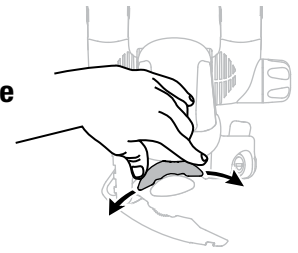

Blocks will self tighten when BowDown is tightened.

6 SECURE BOWDOWN TO CROSSBAR

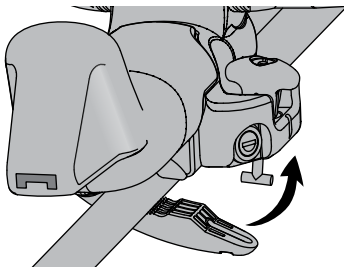

Close bail around crossbar, passing t-bolt through bail.

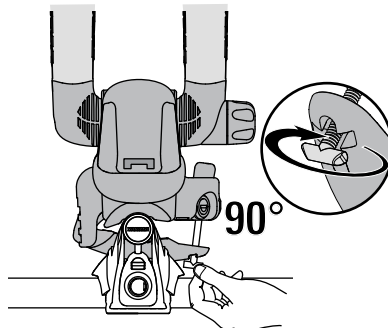

Rotate t-bolt.

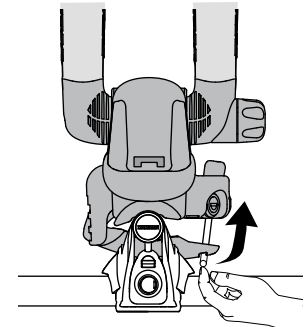

Push t-bolt to rest in slot.

NOW COMPLETELY TIGHTEN THE BOWDOWN USING FIRM PRESSURE.

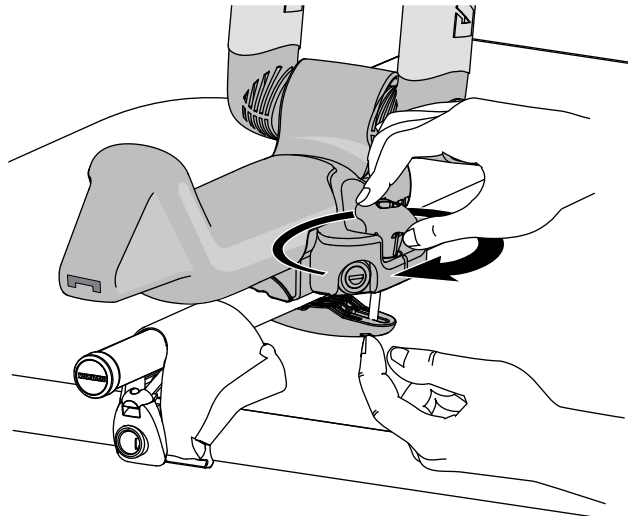

7 INSTALL SECOND BOWDOWN

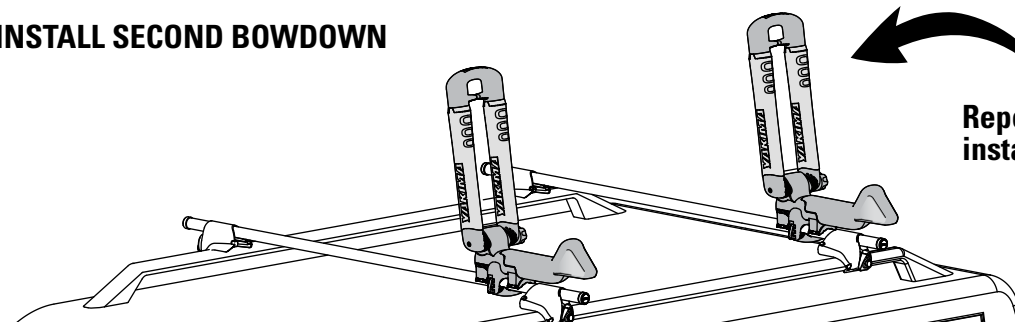

Repeat Steps 1 through 6 to install second BowDown.

8 LOAD THE BOAT— TIE IT DOWN WITH STRAPS

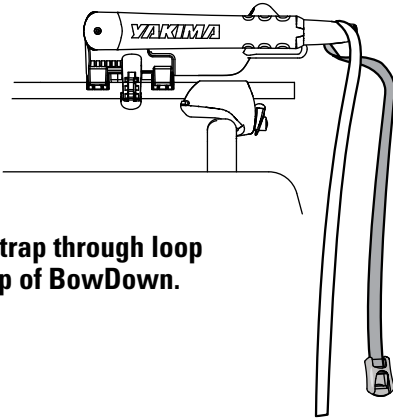

Pass strap through loop at top of BowDown.

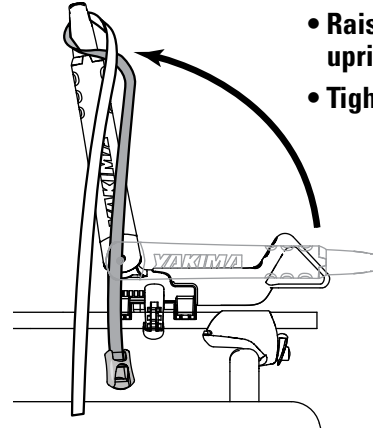

- Raise BowDown to upright position.
- Tighten the red knob.

LOOP STRAP AROUND BOWDOWN POST.

Cross lines and set aside.

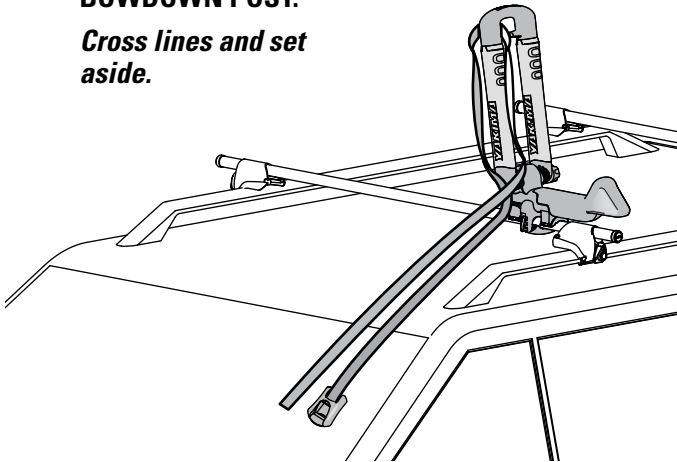

LOAD BOAT.

- Bring straps up and over boat.
- Hang to the side.

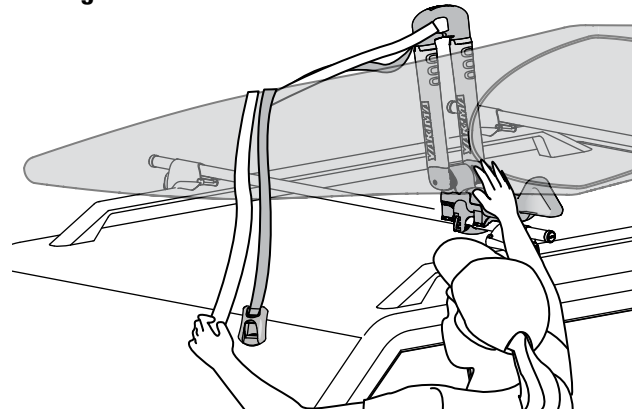

- Slide the strap to the top of the padded arm as shown.
- Slide buckle up so that it hangs at top edge of boat.

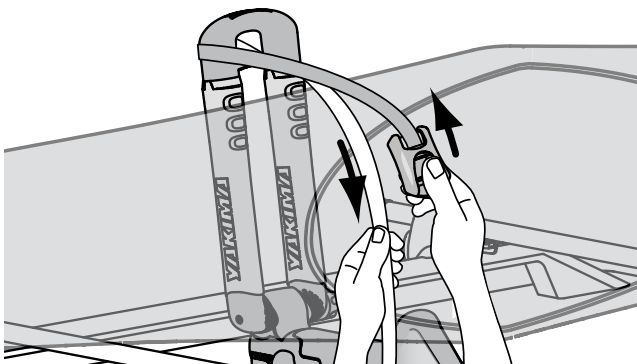

- Bring strap under the CROSSBAR, and INSIDE of tower.

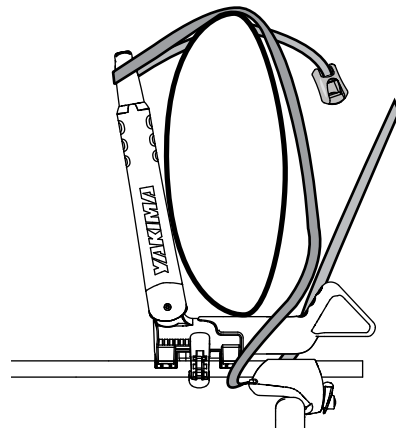

CONTINUE TO TIE IT DOWN WITH STRAPS

CONNECT AND TIGHTEN

- Insert end of strap into buckle as shown.

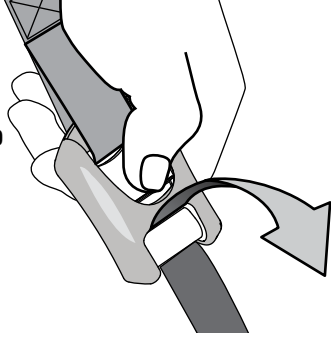

TIGHTEN STRAPS:

- To tighten straps, hold and pull.
- Secure extra strap.

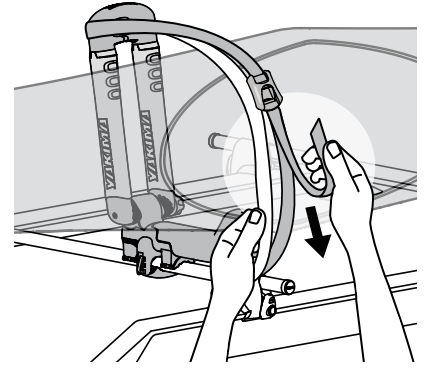

ALWAYS THREAD STRAP THROUGH UPPERMOST OPENING IN BOWDOWN.

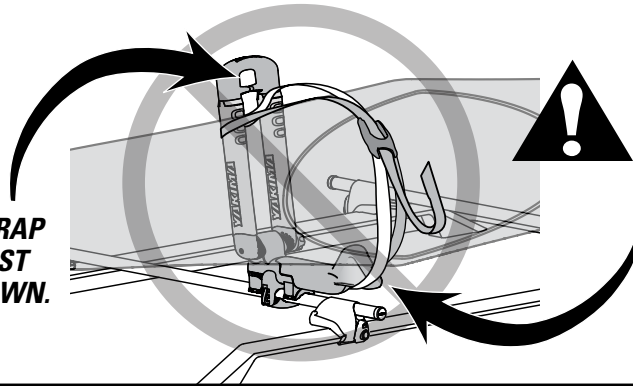

NEVER LOOP STRAP UNDER BOWDOWN!
Strap must be looped under crossbar.

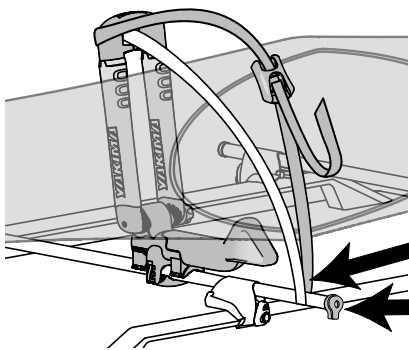

Strap outside of tower.

Use Strap Cap.

NOTE: Straps are to be inside of towers. If straps must be outside of tower due to tower/bar position, use **STRAP CAPS** (Yakima part number 8005015) to prevent straps from sliding off the end of the crossbars.

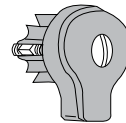

Yakima part number 8005015 (sold separately).

9

INSTALL SKS LOCKS ACCORDING TO LOCK INSTRUCTIONS

(Purchased separately).

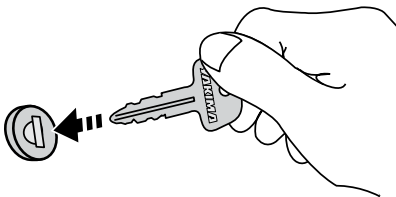

Lines on adjustment knob and BowDown base must be aligned to lock the BowDown.

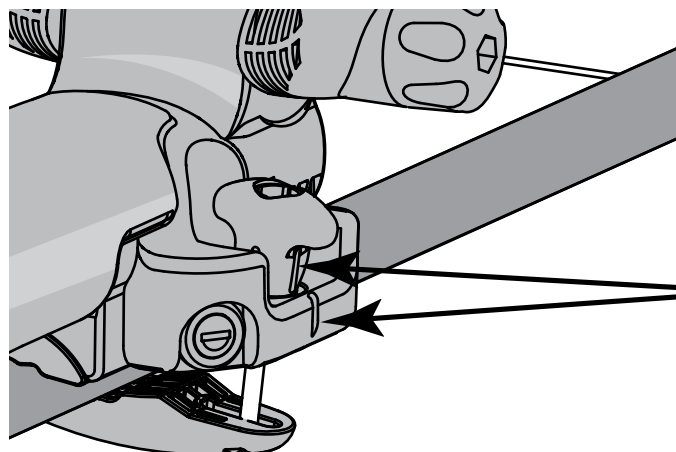

Align

BOW STERN TIE DOWN ATTACHMENT

10 Attach buckle strap to boat.

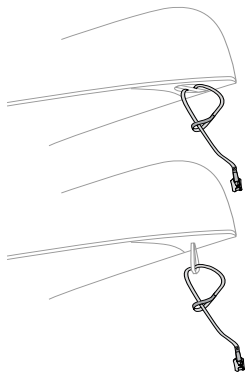

Attach strap to *grab handle* or *rescue bar* and pull tight.

11 Attach hook to plain strap loop.

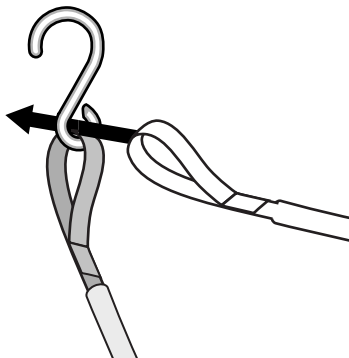

12 Hook the strap to a metal surface on the bumper, tow loop, or frame hole using hook.

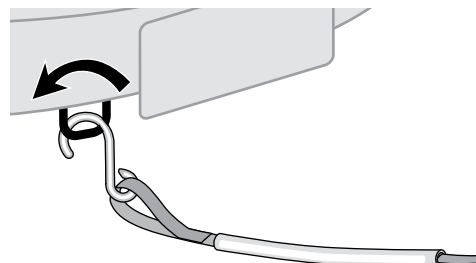

13 Slide plastic tube to protect vehicle at contact point.

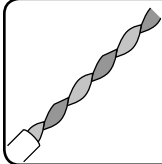

NOTE: Twisting the strap will help reduce wind vibration.

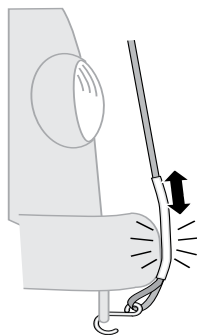

15 Adjust strap tension by pulling plain end.

- Apply even pressure to front and rear straps.
- Bind up and tie off any excess strap.

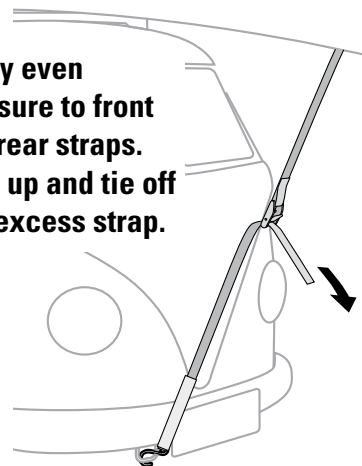

14 Insert end of plain strap into buckle.

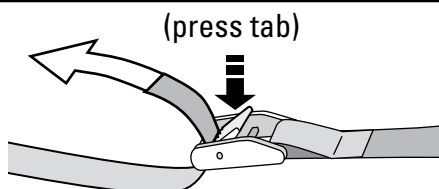

Failure to secure front and rear of long loads to ends of vehicle can result in property damage, personal injury, or death.



Check straps periodically during travel and tighten if necessary. Replace any straps that are worn or frayed before using (see your Yakima dealer).

Now that you've installed your BowDown take a moment to enjoy your beverage of choice.

Use the built in bottle opener to crack open a cold one.

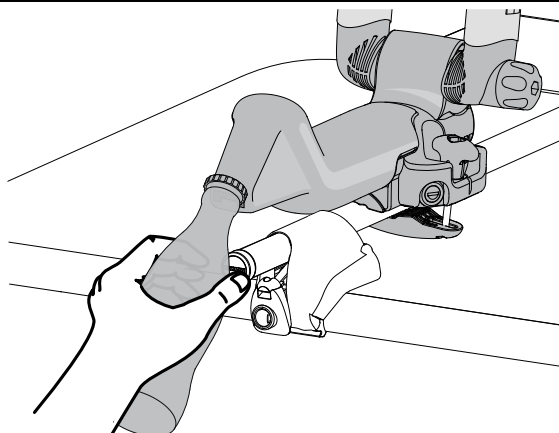

- Do not drink alcohol and drive.
- Do not drink alcohol and boat.



BEFORE DRIVING AWAY

- Test movement by rocking boat.
- Tighten again if loose.
- Make sure knob is tight.
- **READ ALL CAUTIONS AND LIMITS.**

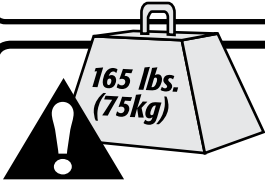

WEIGHT LIMITS

Follow the YAKIMA Fit List or check online at Yakima.com for your rack's weight limit. Do not exceed the weight limit of your vehicle's racks.

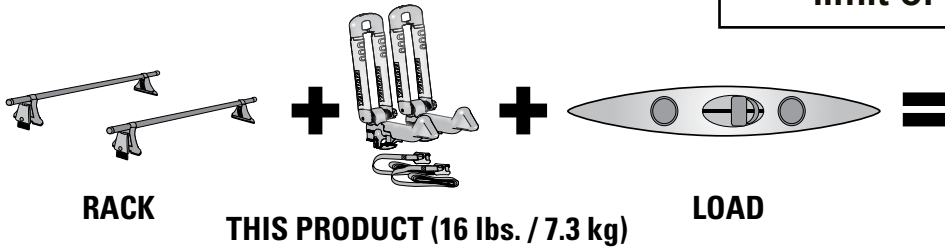

**(Some vehicles will be rated lower than 165 lbs. (75 kg))*

IF YOU REMOVE YOUR CARRIER, FOLLOW INSTRUCTIONS TO INSTALL AGAIN.

Follow safety checks in accessory instructions before every installation.

REAR HATCH

Some longer loads may prevent the rear hatch from fully opening.

ALWAYS USE CAUTION WHEN OPENING YOUR HATCH.

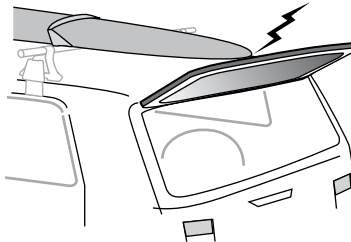

ANTENNA

Antenna on the roof may need to be removed to prevent interference with long loads.



WARNING: BE SURE ALL HARDWARE IS SECURED ACCORDING TO INSTRUCTIONS. ATTACHMENT HARDWARE CAN LOOSEN OVER TIME. CHECK BEFORE EACH USE, AND TIGHTEN IF NECESSARY.

MAINTENANCE: Use non-water soluble lubricant on screws. Use a soft cloth with water and mild detergent to clean plastic parts.

REMOVE ACCESSORY BEFORE ENTERING AN AUTOMATIC CAR WASH.

TECHNICAL ASSISTANCE OR REPLACEMENT PARTS
Contact your dealer, or visit www.yakima.com, or call (888)925-4621
Monday through Friday, 7:00 AM to 5:00 PM, PST



This product is covered by YAKIMA's "Love It Till You Leave It" Limited Lifetime Warranty. To obtain a copy of this warranty, go online to www.yakima.com or email us at yakwarranty@yakima.com or call (888) 925-4621

KEEP THESE INSTRUCTIONS!

YAKIMA BowDown

FR

DISTANCE MINIMALE ENTRE LES BARRES TRANSVERSALES : 61 CM (24 POUCHES)

PORTE-BAGAGES D'ORIGINE : Consulter les notes de la liste de compatibilité ou le site Yakima.com pour trouver la distance à employer entre les barres transversales.

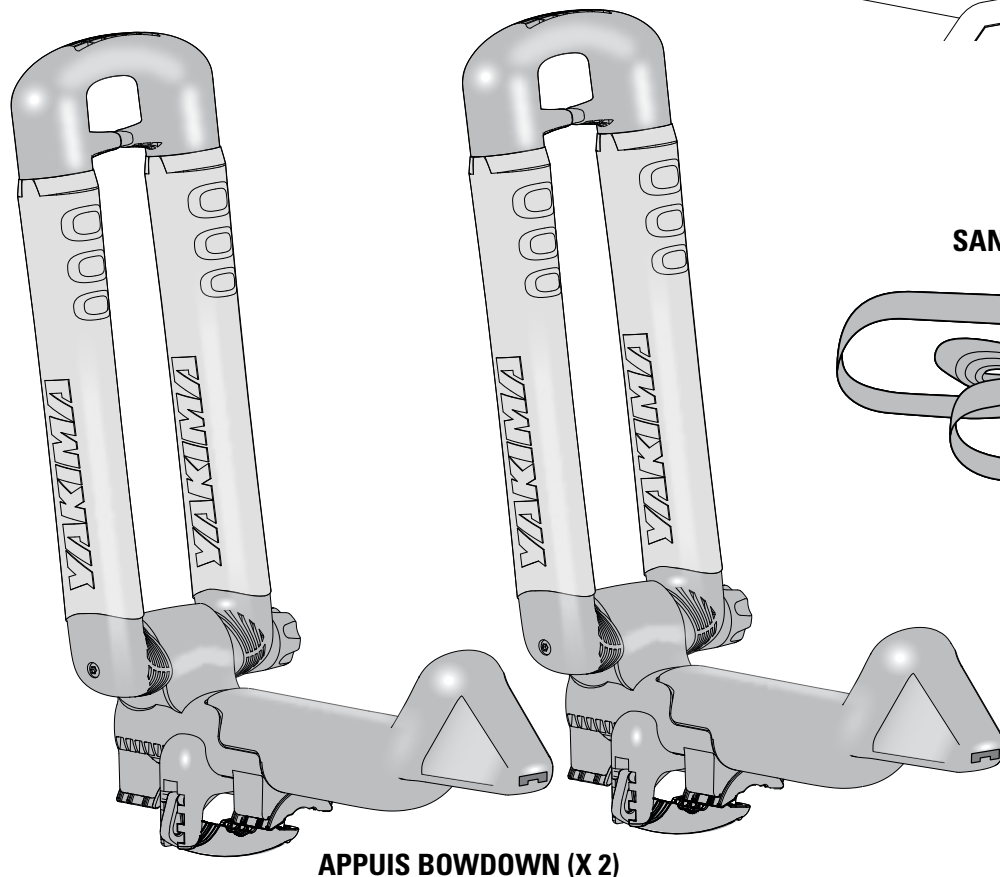
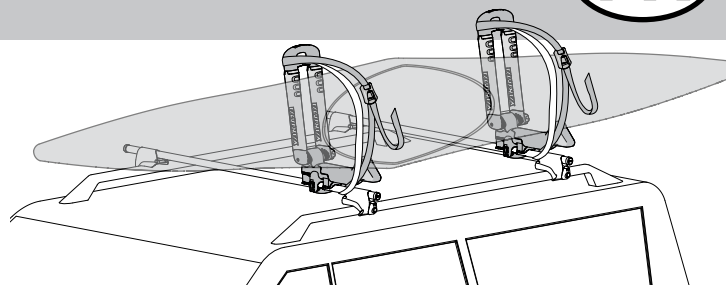

APPUIS BOWDOWN (X 2)

SANGLES RÉSIDANTES (X 2)

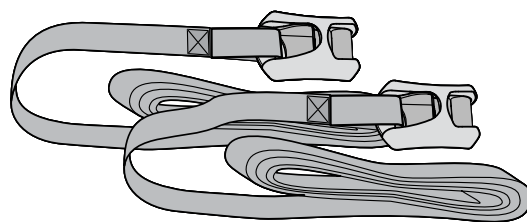

BOULONS EN T NOIRS COURTS (X 2)

SANGLES D'ARRIMAGE AVANT/ARRIÈRE

Sangles avec boucle (x 2)

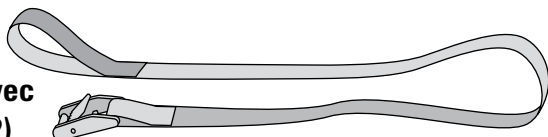

Manchons en plastique (x 2)



Crochets en acier (x 2)



Sangles sans boucle (x 2)



AVERTISSEMENT IMPORTANT

IL EST ESSENTIEL QUE TOUTS LES SUPPORTS ET ACCESSOIRES YAKIMA SOIENT FIXÉS ET ATTACHÉS SOLIDEMENT À VOTRE VÉHICULE. **UNE ATTACHE INADÉQUATE PEUT CAUSER UN ACCIDENT DU VÉHICULE ET DES BLESSURES GRAVES OU MORTELLES POUR VOUS OU POUR LES AUTRES. IL VOUS INCOMBE DE FIXER LES SUPPORTS ET ACCESSOIRES À VOTRE VÉHICULE, DE VÉRIFIER LES ATTACHES AVANT D'UTILISER LE DISPOSITIF, DE VÉRIFIER RÉGULIÈREMENT QUE LE PRODUIT EST AJUSTÉ, ET QU'IL N'EST PAS USÉ OU ENDOMMAGÉ. IL VOUS FAUT DONC LIRE ET COMPRENDRE TOUTES LES DIRECTIVES ET MISES EN GARDE FOURNIES AVEC VOTRE PRODUIT YAKIMA AVANT DE L'INSTALLER OU DE L'UTILISER. SI TOUTES LES INSTRUCTIONS ET MISES EN GARDE NE SONT PAS COMPRIS, OU SI L'ON N'A AUCUNE EXPÉRIENCE EN MÉCANIQUE ET QUE L'ON N'EST PAS TRÈS FAMILIER AVEC LES PROCÉDURES D'INSTALLATION, FAIRE INSTALLER LE PRODUIT PAR UN INSTALLATEUR PROFESSIONNEL COMME UN GARAGISTE QUALIFIÉ OU RÉPARATEUR DE CARROSSERIE.**

PRÉPARER LE MONTAGE

1

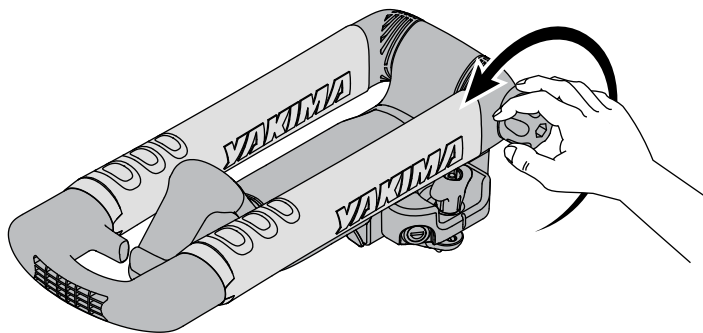

Desserrer le bouton de 6 ou 8 tours, mais sans l'enlever.

2

Relever l'appui à la verticale et serrer ensuite le bouton avec une bonne pression.

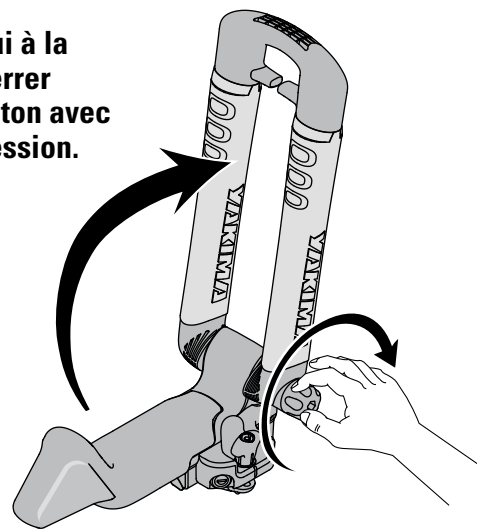

3 RÉGLER LA POSITION DE LA MÂCHOIRE (SI NÉCESSAIRE)

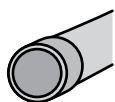

Encoche du milieu pour les barres rondes.

BARRES RONDES

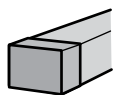
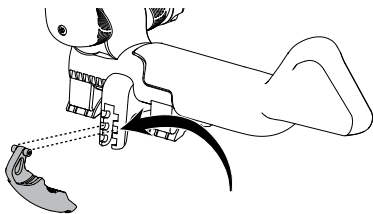

Encoche du haut pour les barres carrées

BARRES CARRÉES

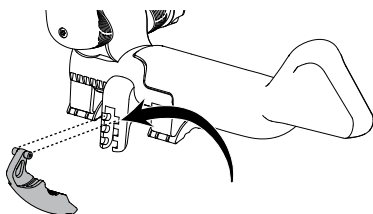

BARRES D'ORIGINE SEULEMENT

Choisir l'encoche offrant le montage le plus solide.

REMARQUE : pour certaines barres d'origine plus petites, il faudra peut-être employer les boulons en T noirs courts inclus avec le produit.

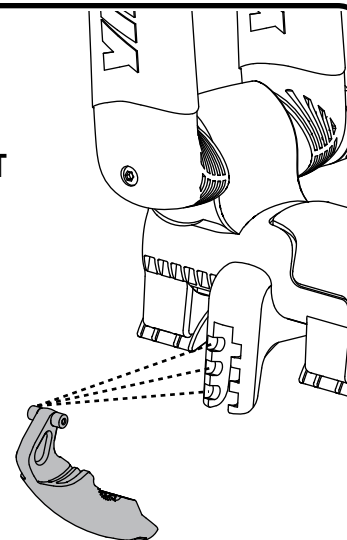

POSER LES APPUIS BOWDOWN

4 POSITIONNER LES APPUIS SUR LE VÉHICULE

Positionner l'appui sur la barre transversale.

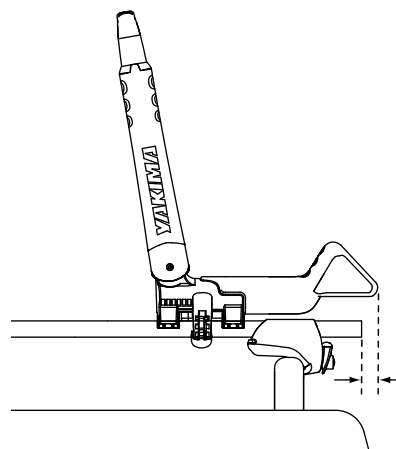
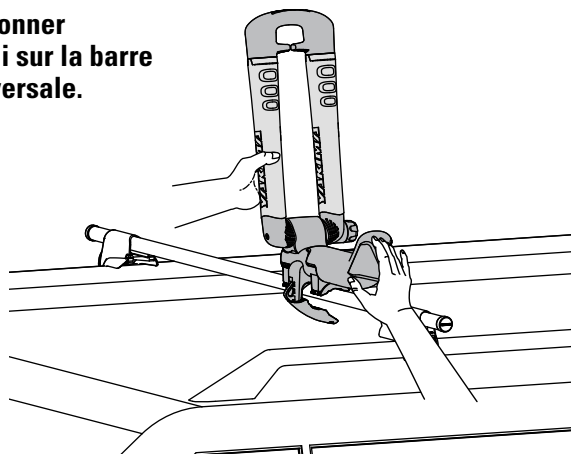

Positionner le bout de l'appui de manière qu'il dépasse légèrement au-delà de la barre transversale.

5 RÉGLER L'APPUI À LA VERTICALE

L'appui devrait être le plus proche possible de la verticale. Au besoin, corriger le montage.

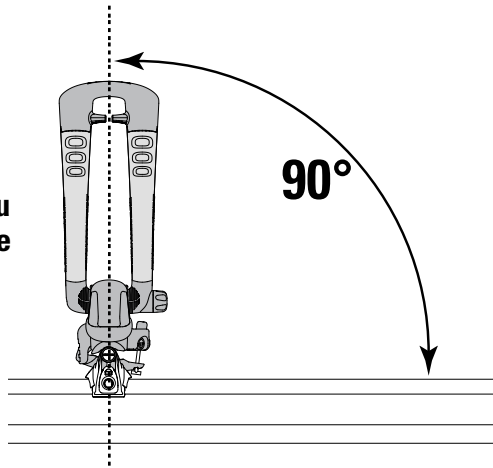

Au besoin, modifier la position des coussinets.

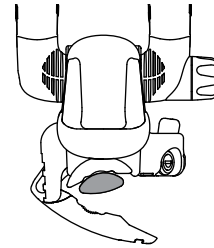
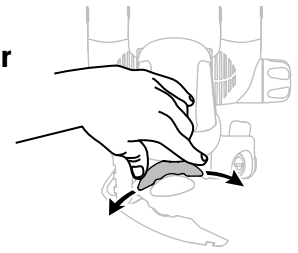

Il se bloqueront d'eux-mêmes quand on serrera la mâchoire.

6 SERRER L'APPUI SUR LA BARRE TRANSVERSALE

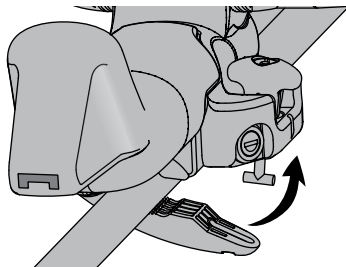

Fermer la mâchoire sur la barre, en enfilant le boulon en T à travers la mâchoire.

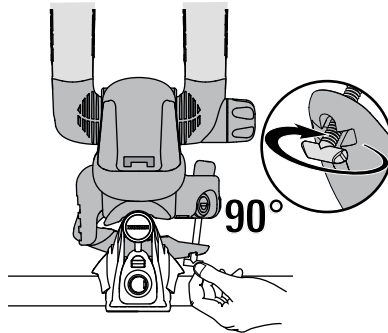

Faire pivoter le boulon en T.

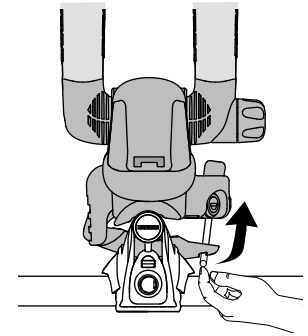

Enfoncer le boulon en T dans sa fente.

SERRER MAINTENANT L'APPUI COMPLÈTEMENT EN APPLIQUANT UNE PRESSION FERME.

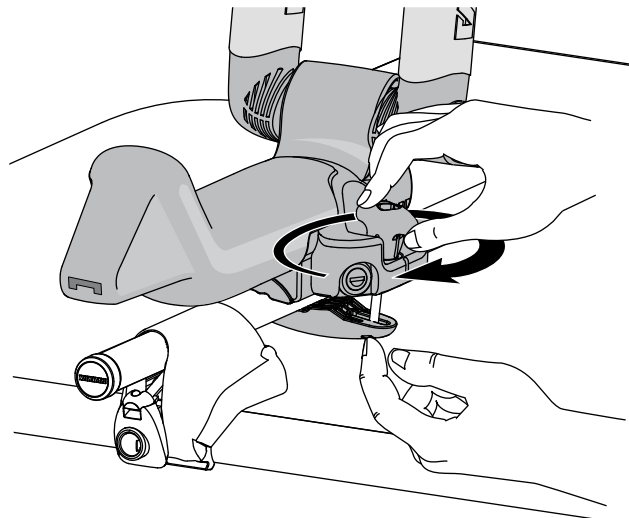

7 POSER LE DEUXIÈME APPUI

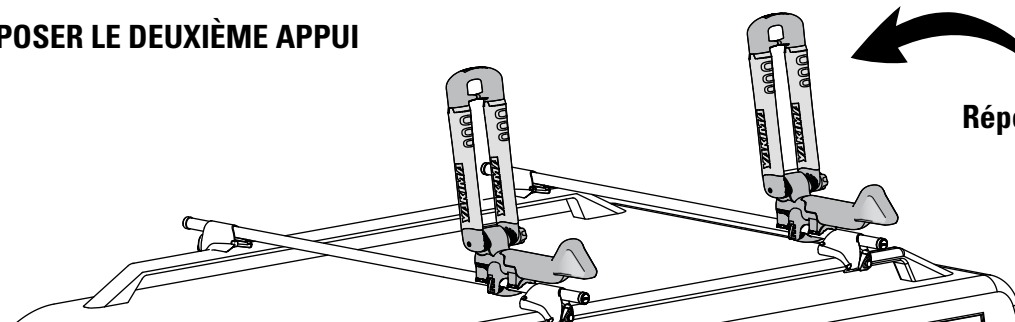

Répéter les opérations 1 à 6.

8 CHARGER L'EMBARCATION ET L'ARRIMER AVEC LES SANGLES

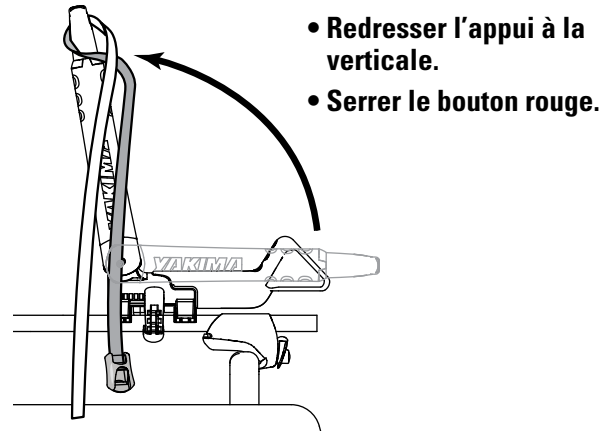
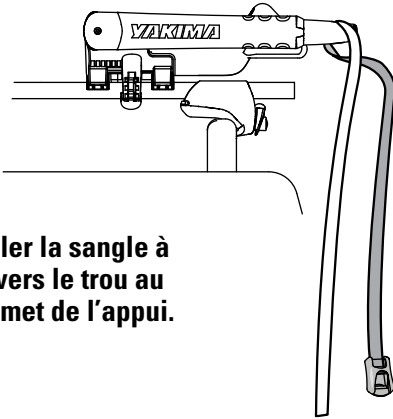

PASSER LA SANGLE AUTOUR DE L'APPUI.

Croiser les deux brins et les mettre sur le côté.

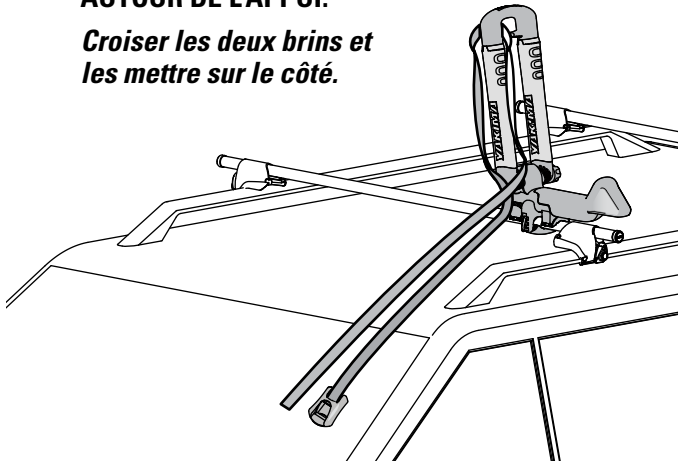

CHARGER L'EMBARCATION.

- Ramener les deux brins par-dessus l'embarcation.
- Les mettre sur le côté.

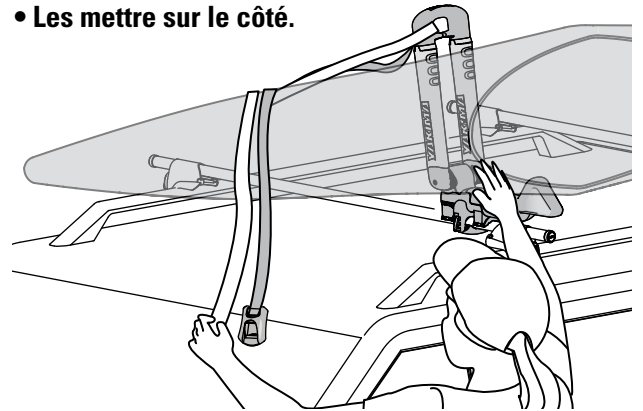

- Faire glisser la sangle pour l'amener au sommet de l'appui tel qu'illustré.
- Tirer sur la sangle pour que la boucle se retrouve près du haut du kayak.

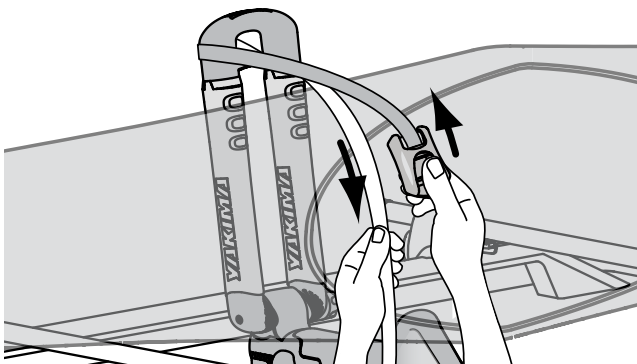

- Passer la sangle sous la BARRE TRANSVERSALE et À L'INTÉRIEUR du pied.

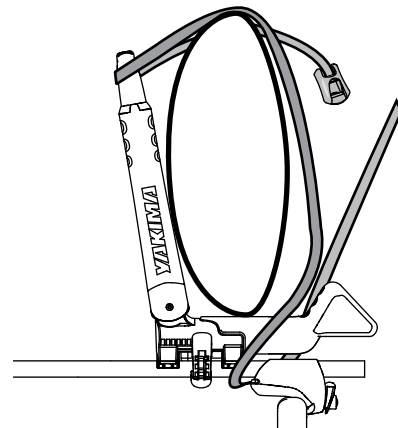

ARRIMAGE DE L'EMBARCATION (SUITE)

RÉUNIR LES DEUX BOUTS DE LA SANGLE ET SERRER

- Enfiler le bout de la sangle dans la boucle tel qu'illustré.

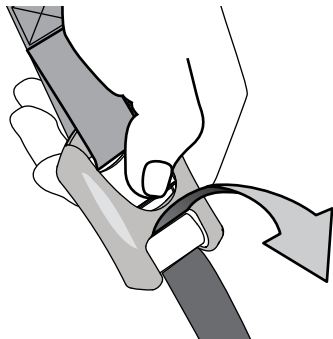

SERRER LES SANGLES :

- Pour serrer les sangles, tirer vers le bas en retenant l'autre brin.
- Attacher l'excédent.

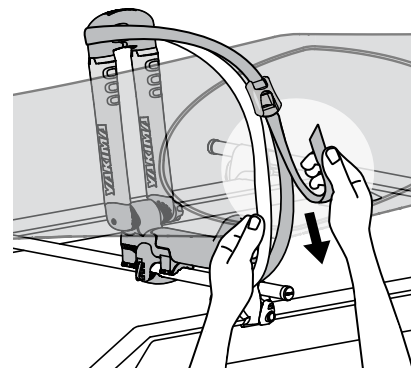

TOUJOURS ENFILER LA SANGLE À TRAVERS DANS LE TROU SUPÉRIEUR DE L'APPUI.

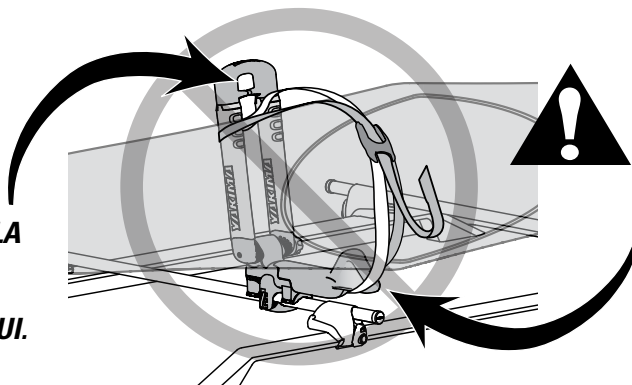

NE JAMAIS PASSER LA SANGLE SOUS LA BASE DE L'APPUI !

La sangle doit passer sous la barre transversale.

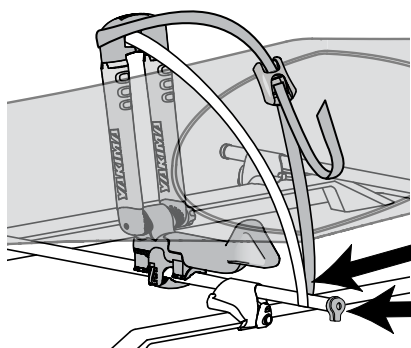

Si la sangle est à l'extérieur des pieds...

... employer les butées STRAP CAP

REMARQUE : les sangles doivent passer à l'intérieur des pieds. Si l'on est obligé de faire passer les sangles à l'extérieur des pieds à cause de la position des barres ou des pieds, employer les butées STRAP CAP (article Yakima n° 8005015) pour empêcher les sangles de glisser par-dessus le bout des barres.

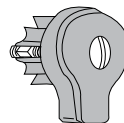

Article Yakima n° 8005015
(vendu à part)

9

POSER LES SERRURES SKS EN SUIVANT LES INSTRUCTIONS QUI LES ACCOMPAGNENT (vendues à part)

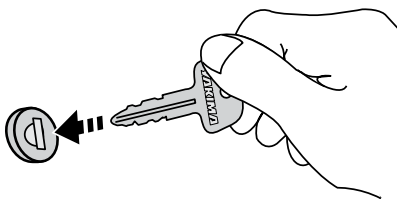

Les lignes du bouton de serrage et de la base de l'appui doivent être alignées pour pouvoir verrouiller.

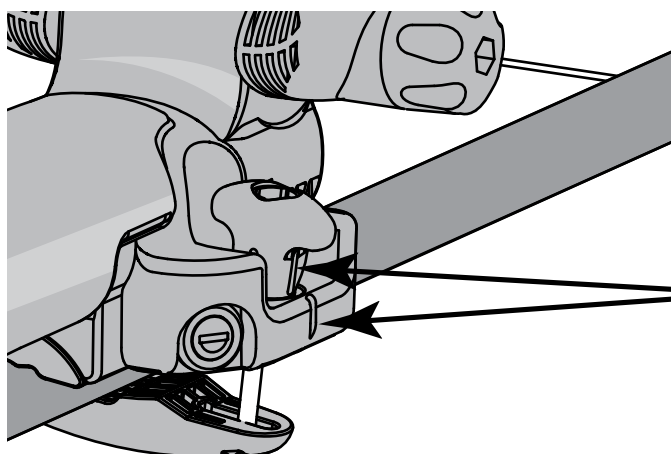

Aligner

INSTALLATION DES SANGLES D'ARRIMAGE AVANT/ARRIÈRE

- 10** Attacher la sangle avec boucle à l'embarcation.

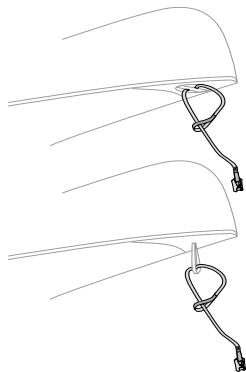

Fixer la sangle à la poignée ou à la barre de transport et bien serrer.

- 11** Fixer le crochet dans l'anneau de la sangle sans boucle.

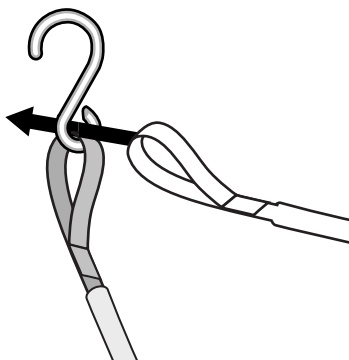

- 12** Accrocher la sangle à un rebord métallique du pare-chocs, à un anneau de remorquage ou dans un trou du châssis.

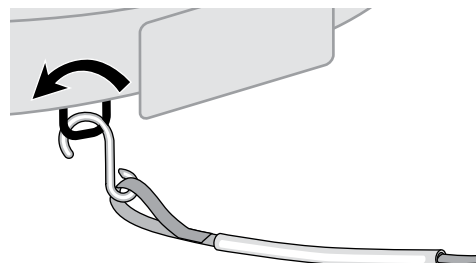

- 13** Faire coulisser le manchon en plastique pour protéger le véhicule au point de contact.

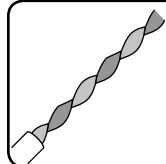

REMARQUE : si l'on donne plusieurs tours à la sangle elle vibrera moins dans le vent.

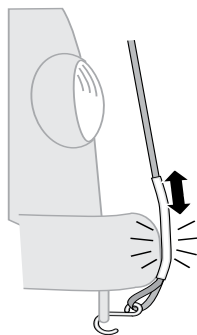

- 15** Régler la tension de la sangle en tirant sur le bout libre.

- Tendre également les sangles avant et arrière.
- Enrouler et attacher l'excédent des sangles.

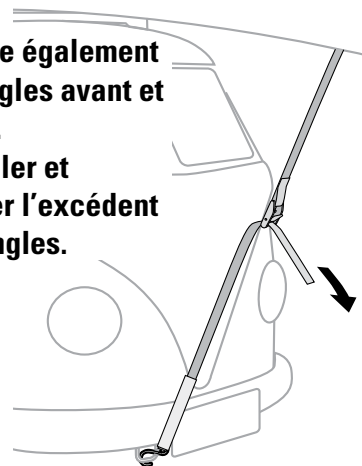

- 14** Enfiler le bout de la sangle sans boucle dans la boucle.

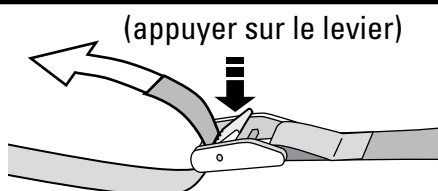

Toujours attacher le bout des charges longues à l'avant et à l'arrière du véhicule, sous peine de risquer de provoquer des dommages, des blessures ou même la mort.



Vérifier les sangles régulièrement durant le trajet et les serrer au besoin. Si une sangle est usée ou effilochée, la remplacer (consulter le dépositaire Yakima).

Maintenant que les appuis Bowdown sont installés, on peut prendre un moment pour se rafraîchir avec la boisson de son choix !

On peut se servir du décapsuleur incorporé pour s'en déboucher une bien fraîche !

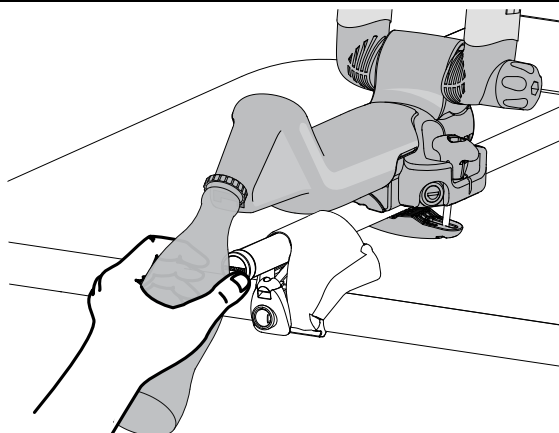

- Ne pas conduire si l'on a bu de l'alcool.
- Ne pas faire du bateau si l'on a bu de l'alcool.



AVANT DE PRENDRE LA ROUTE

- Vérifier la solidité du montage en balançant l'embarcation.
- Serrer les sangles ou les boulons un peu plus s'il y a du jeu.
- LIRE TOUS LES AVERTISSEMENTS ET RESPECTER LES LIMITES.

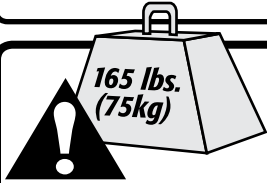

LIMITE DE CHARGEMENT

Consulter la liste de compatibilité YAKIMA ("Fit list") ou le site yakima.com pour connaître la limite de chargement. Ne pas dépasser la limite de chargement fixée pour le porte-bagages d'origine.

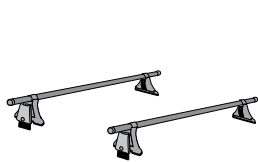

PORTE-BAGAGES

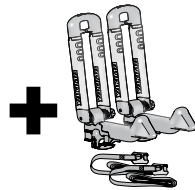

CE PRODUIT (16 lbs. / 7.3 kg)

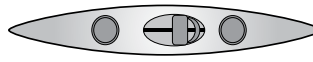

CHARGE

= Ne pas dépasser 75 kg (165 lb) à moins d'indication contraire.

**Certains véhicules acceptent moins de 75 kg (165 lb)*

SI L'ON ENLÈVE LE PORTE-EMBARCATION, SUIVRE LES INSTRUCTIONS POUR LE REMETTRE EN PLACE.
Respecter les consignes de sécurité figurant dans les instructions avant chaque montage.

HAYON

Certaines charges particulièrement longues pourraient empêcher d'ouvrir complètement le hayon.
TOUJOURS OUVRIR LE HAYON AVEC PRUDENCE.

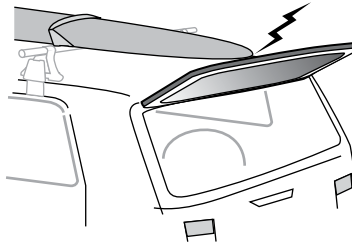

ANTENNE

Il faudra peut-être enlever l'antenne du toit si elle gêne les charges longues.



ATTENTION : S'ASSURER QUE LE MONTAGE EST SOLIDE ET CONFORME AUX INSTRUCTIONS. LES DISPOSITIFS DE FIXATION PEUVENT SE DESSERRER À LA LONGUE. LES INSPECTER AVANT CHAQUE UTILISATION ET LES RESSERRER AU BESOIN.

ENTRETIEN : lubrifier les boulons avec un lubrifiant non soluble à l'eau. Nettoyer les pièces en plastique avec un chiffon, de l'eau et un savon doux.

ENLEVER L'ACCESSOIRE AVANT DE PASSER DANS UN LAVE-AUTO AUTOMATIQUE.

RENSEIGNEMENTS TECHNIQUES OU PIÈCES DE RECHANGE, prière de contacter votre dépositaire ou appeler au (888) 925-4621, du lundi au vendredi entre 7h et 17h, heure du Pacifique.

LOVE IT TILL YOU LEAVE IT
LIFETIME
WARRANTY

Ce produit est couvert par la garantie limitée « Tant que durera notre histoire d'amour » YAKIMA. Pour se procurer une copie de cette garantie, aller en ligne à www.yakima.com ou nous envoyer un courriel à yakwarranty@yakima.com ou appeler au (888) 925-4621.

CONSERVER CES INSTRUCTIONS!

YAKIMA BowDown

ES

SEPARACIÓN MÍNIMA ENTRE TRAVESAÑOS: 24" (61CM)

PARA LOS BASTIDORES DE ORIGEN: Verifique las notas en la lista de compatibilidad, o visite el sitio Yakima.com para conocer la separación entre las barras transversales de su vehículo.

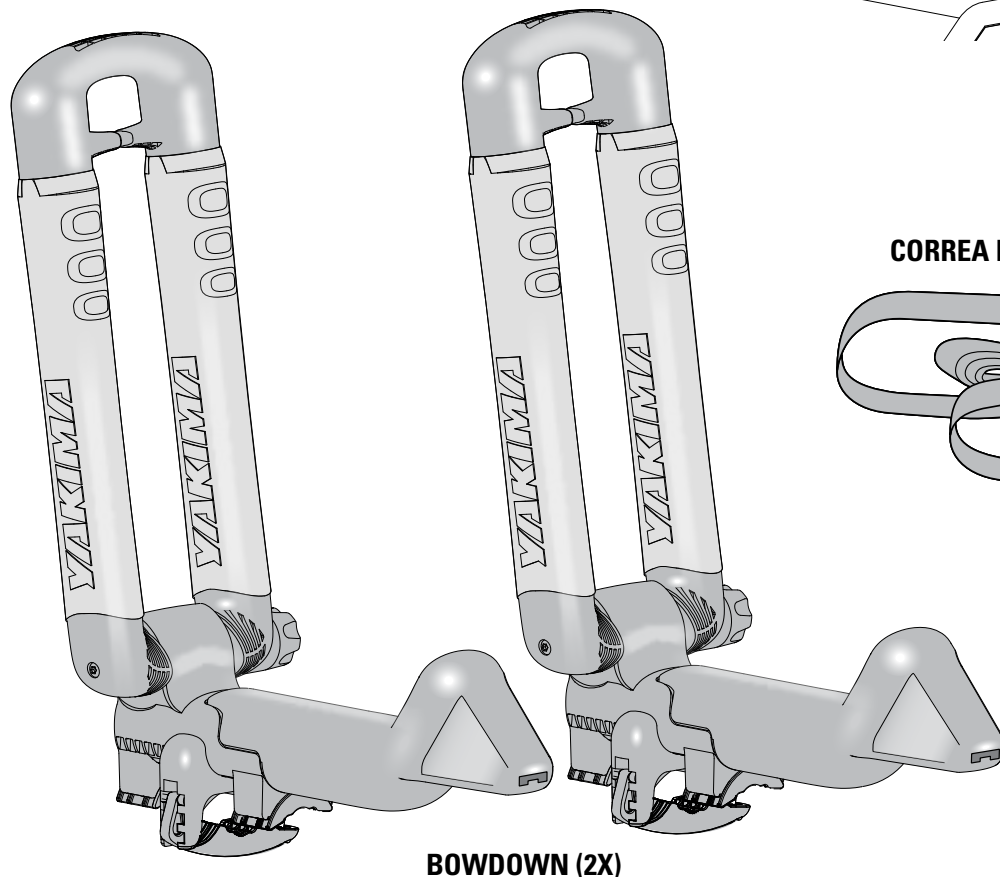
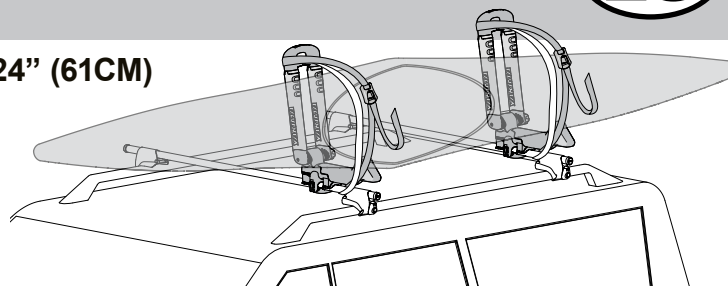

BOWDOWN (2X)

CORREA EXTRA RESISTENTE (2X)

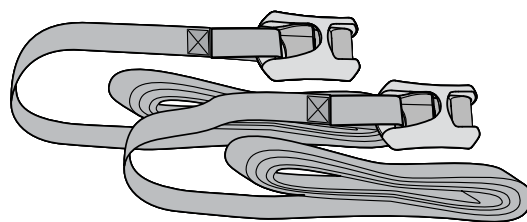

TORNILLO NEGRO EN T CORTO (2X)

AMARRE PARA PROA Y POPA

Correa con hebilla (2X)

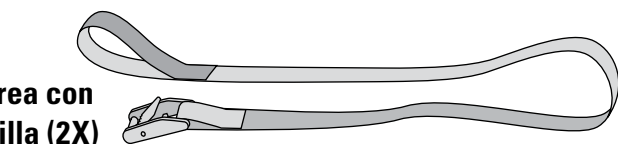

Tubo plástico (2X)

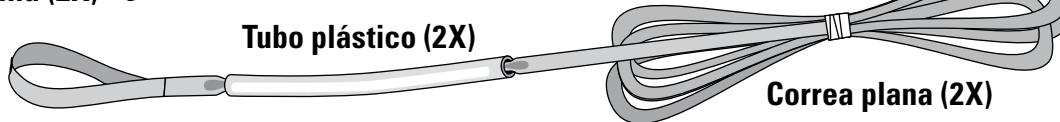

Correa plana (2X)

Gancho de acero (2X)



ADVERTENCIA IMPORTANTE

ES FUNDAMENTAL QUE TODOS LOS BASTIDORES Y ACCESORIOS YAKIMA ESTÉN FIJADOS DE MANERA CORRECTA Y SEGURA AL VEHÍCULO. UNA INSTALACIÓN DEFICIENTE PODRÍA CAUSAR UN ACCIDENTE AUTOMOVILÍSTICO Y PROVOCAR HERIDAS GRAVES O LA MUERTE A USTED O A TERCEROS. USTED ES RESPONSABLE DE LA FIJACIÓN SEGURA DE LOS BASTIDORES Y ACCESORIOS AL VEHÍCULO. VERIFICANDO LAS UNIONES Y AMARRES ANTES DE UTILIZARLOS E INSPECCIONANDO PERIÓDICAMENTE EL AJUSTE DE LOS PRODUCTOS, SU DESGASTE Y POSIBLES DAÑOS. POR ELLO, DEBE LEER Y COMPRENDER TODAS LAS INSTRUCCIONES Y ADVERTENCIAS QUE VIENEN CON LOS PRODUCTOS YAKIMA ANTES DE INSTALARLOS O USARLOS. SI NO ENTIENDE TODAS LAS INSTRUCCIONES Y ADVERTENCIAS, O NO TIENE EXPERIENCIA EN MECÁNICA O NO ESTÁ FAMILIARIZADO CON LOS PROCEDIMIENTOS DE INSTALACIÓN, HAGA INSTALAR EL PRODUCTO POR UN PROFESIONAL.

PREPARE LA INSTALACIÓN.

1

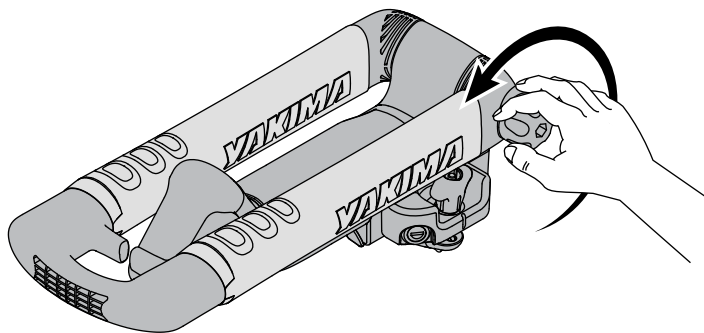

Afloje la perilla 6 a 8 vueltas. No retire la perilla.

2

Levante el BOWDOWN y luego apriete la perilla con una presión firme.

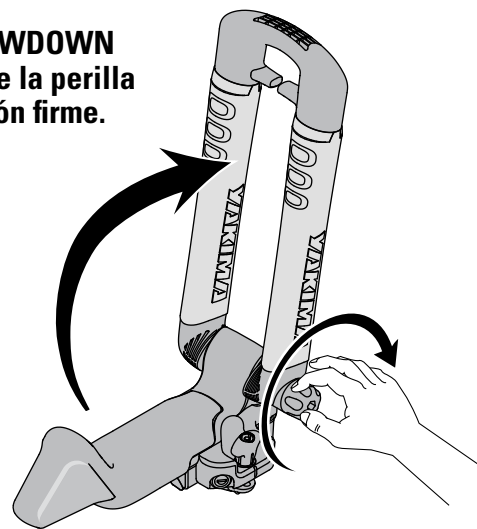

3 AJUSTE LA POSICIÓN DE LA MORDAZA (SI ES NECESARIO)

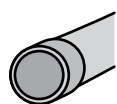

Ranura del medio para las barras cilíndricas.

BARRA CILÍNDRICA

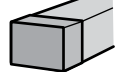
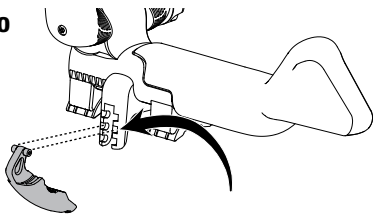

Ranura superior para las barras cuadradas.

BARRA CUADRADA

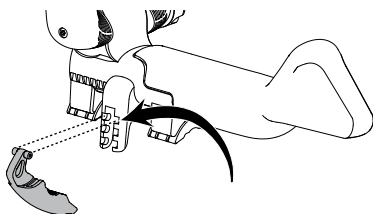

BARRA DE ORIGEN SOLAMENTE

Elija la mejor posición que garantice el agarre más seguro.

NOTA: Es posible que ciertas barras de origen más pequeñas necesiten el uso de tornillos negros en T cortos, incluidos con este producto.

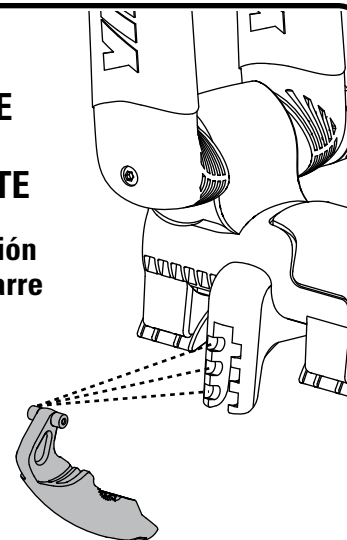

INSTALE EL BOWDOWN.

4 COLOQUE EL BOWDOWN EN EL VEHÍCULO.

Coloque el BowDown en la barra transversal.

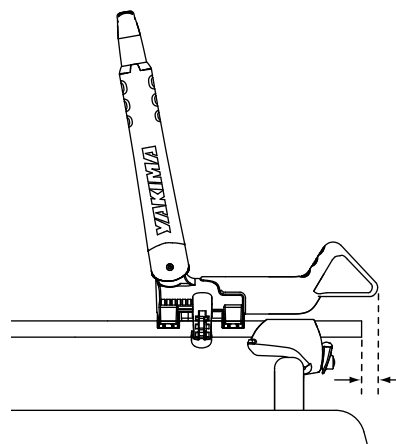
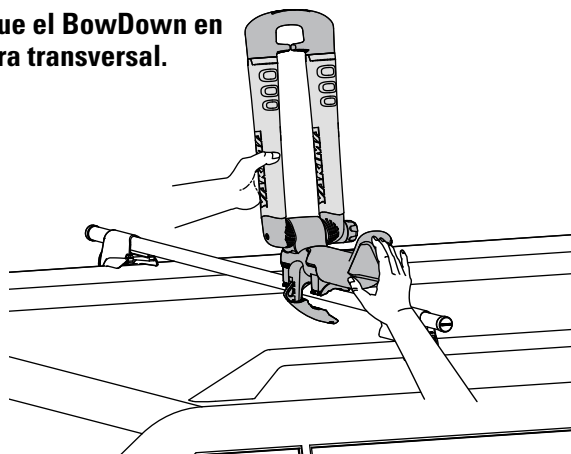

Coloque el extremo del BowDown de modo que sobresalga un poco hacia fuera de las barras transversales.

5 COLOQUE EL BOWDOWN EN POSICIÓN VERTICAL.

El BOWDOWN debe estar lo más vertical posible. En caso de necesidad, ajuste los broches.

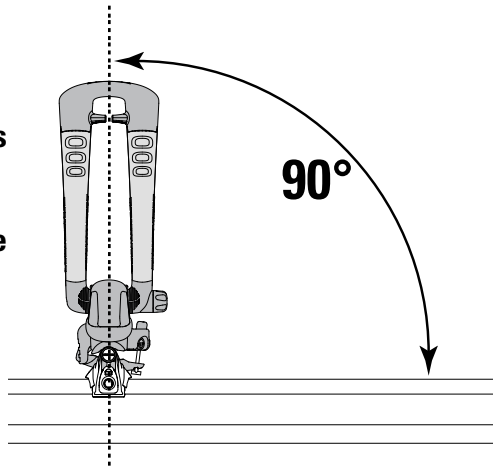

En caso de necesidad ajuste la piezas de relleno.

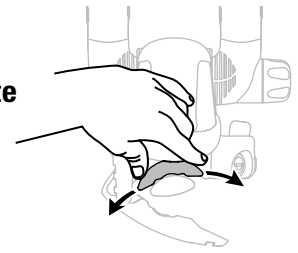

Las piezas de relleno se autoajustarán al apretar el BOWDOWN.

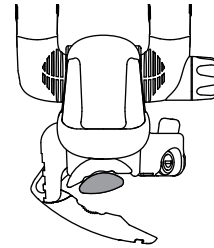

6 ASEGURE EL BOWDOWN A LA BARRA TRANSVERSAL.

Cierre la mordaza alrededor de la barra transversal, pasando el tornillo en T a través de la mordaza.

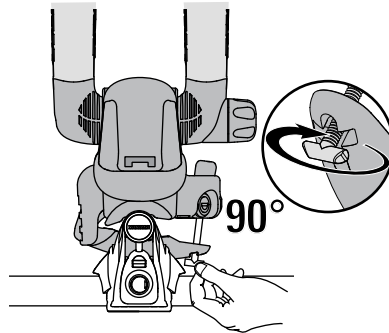
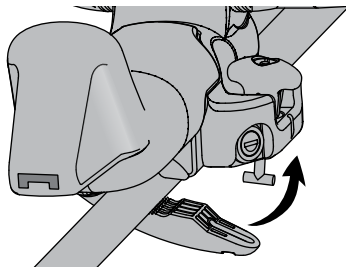

Gire el tornillo en T.

Empuje el tornillo en T para que quede en la ranura.

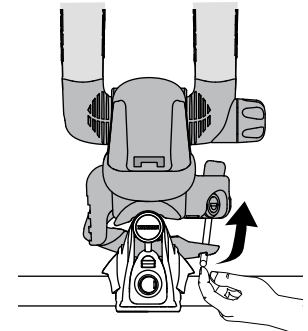

AHORA, APRIETE COMPLETAMENTE EL BOWDOWN EJERCIENDO UNA PRESIÓN FIRME.

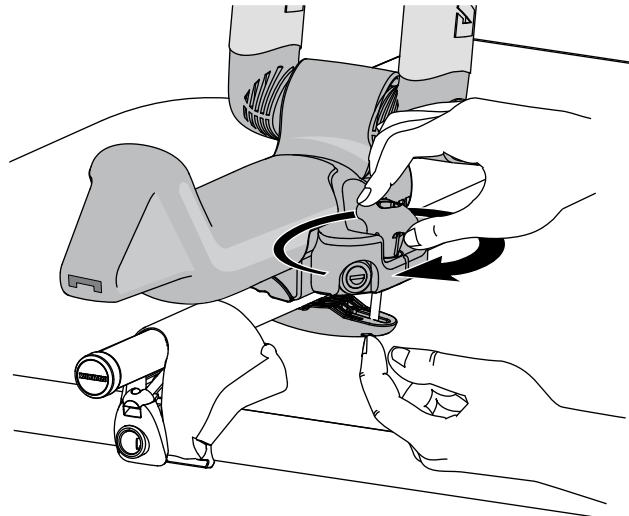

7 INSTALE EL SEGUNDO BOWDOWN.

Repita los pasos 1 a 6 para instalar el segundo BowDown.

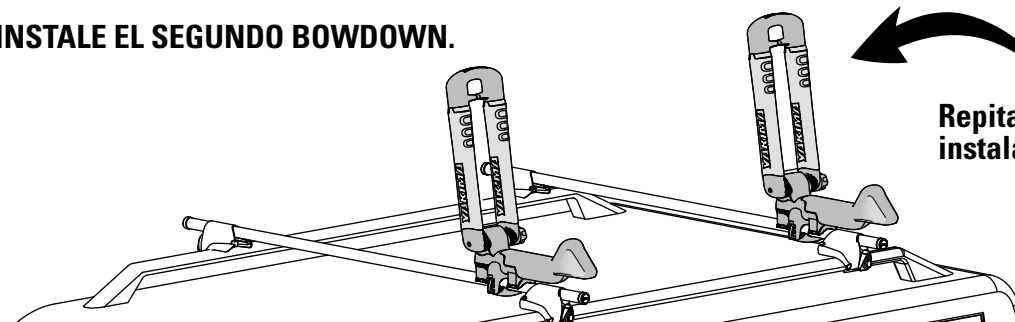

8 CARGUE LA EMBARCACIÓN— ÁTELA CON LAS CORREAS.

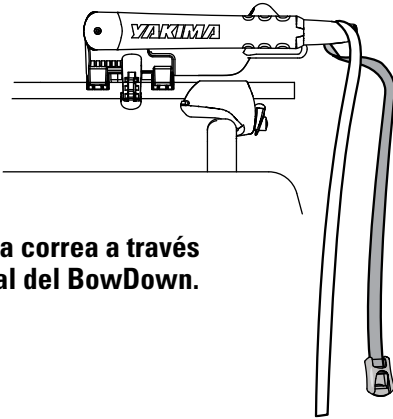

Pase la correa a través del ojal del BowDown.

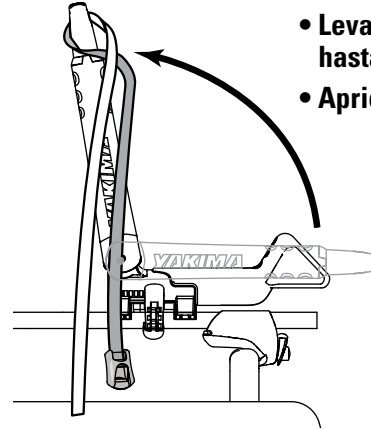

- Levante el BowDown hasta que quede vertical.
- Apriete la perilla roja.

PASE LA CORREA A CADA LADO DEL BOWDOWN .

Cruce los dos extremos de la correa y déjelos a un costado.

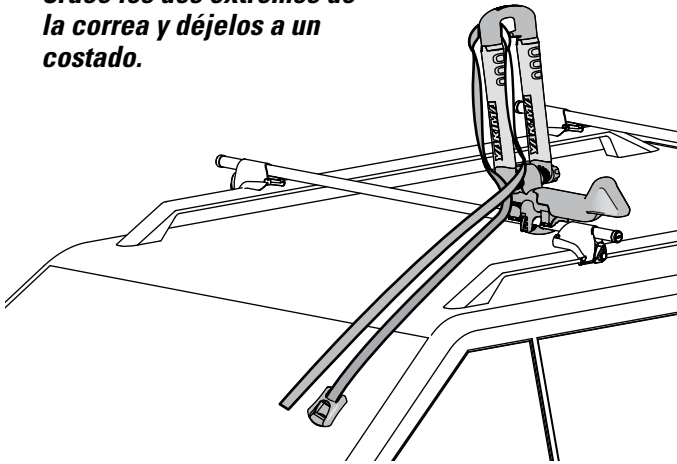

CARGUE LA EMBARCACIÓN.

- Lleve las correas hacia arriba y sobre la embarcación.
- Déjela caer a un lado.

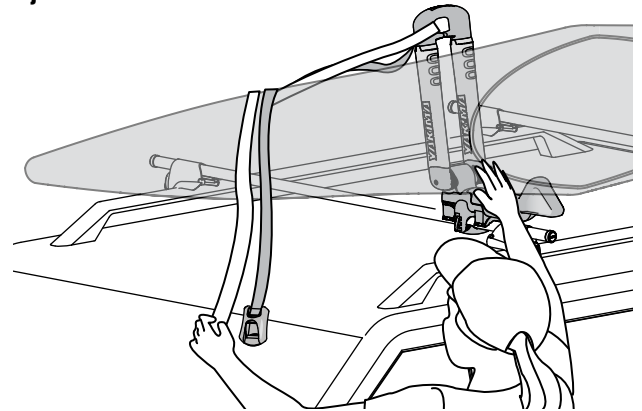

- Deslice la correa hacia la parte superior del brazo acolchado, tal como se ilustra.
- Deslice la hebilla hacia arriba de modo que quede colgando de la parte superior del borde de la embarcación.

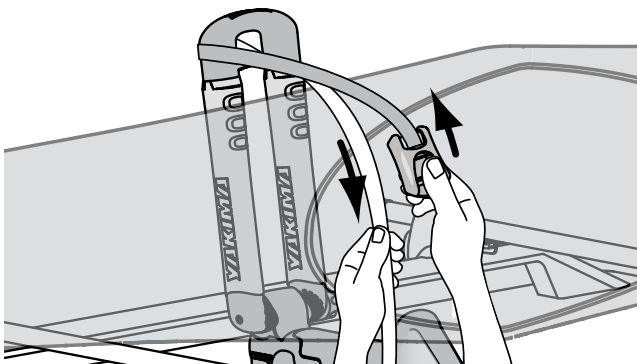

- Pase la correa por debajo de la BARRA TRANSVERSAL y por el INTERIOR de la torre.

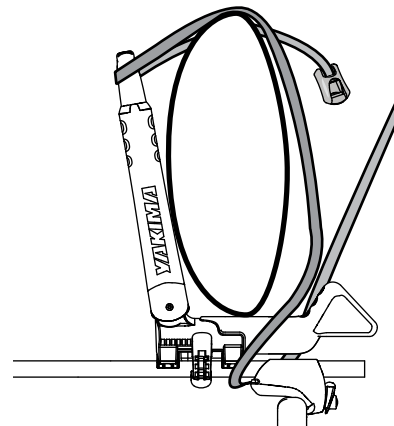

CONTINUE ATANDO LAS CORREAS.

CONECTE Y AJUSTE.

- Inserte el extremo de la correa en la hebilla, como se ilustra.

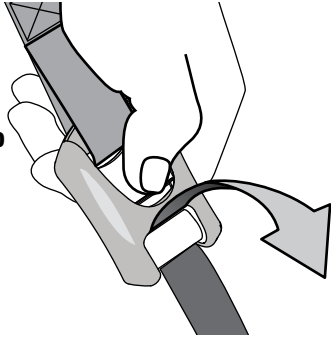

AJUSTE LAS CORREAS:

- Para ajustar las correas, sujete y tire.
- Asegure la correa extra.

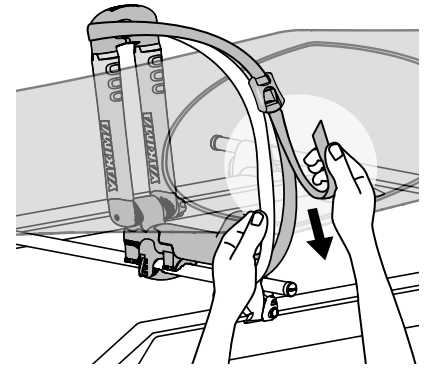

PASE SIEMPRE LA CORREA A TRAVÉS DEL OJAL MÁS ALTO DEL BOWDOWN.

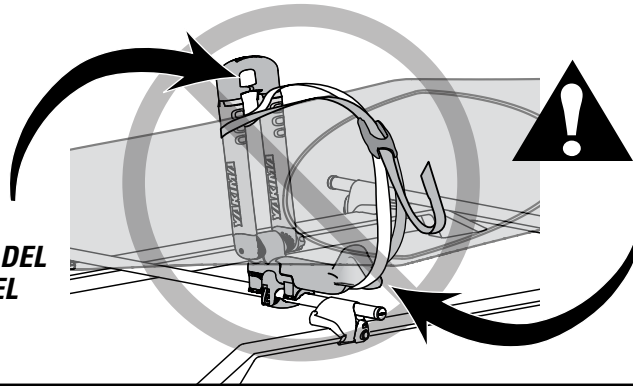

¡NUNCA PASE LA CORREA POR DEBAJO DEL BOWDOWN!

La correa se debe pasar por debajo de la barra transversal.

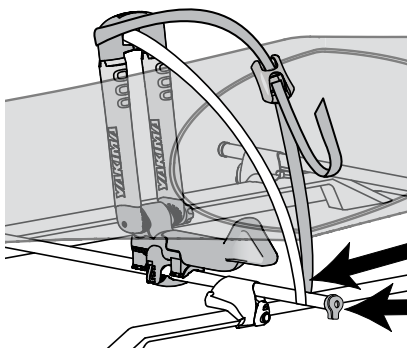

Correa fuera de la torre.

Utilice el Strap Cap.

NOTA: Las correas deben estar dentro de las torres. Si las correas deben quedar fuera de la torre debido a la posición de la torre/barra, utilice los STRAP CAPS (pieza número 8005015 de Yakima) para evitar que las correas resbalen del extremo de las barras transversales.

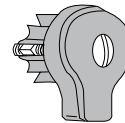

Pieza número 8005015 de Yakima (vendida por separado).

9

INSTALE LAS CERRADURAS SKS SIGUIENDO LAS INSTRUCCIONES.
(Vendidas por separado).

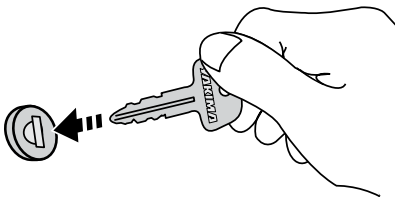

Las líneas de la perilla de ajuste y de la base del BowDown deben estar enfrentadas para que el BowDown quede trabado.

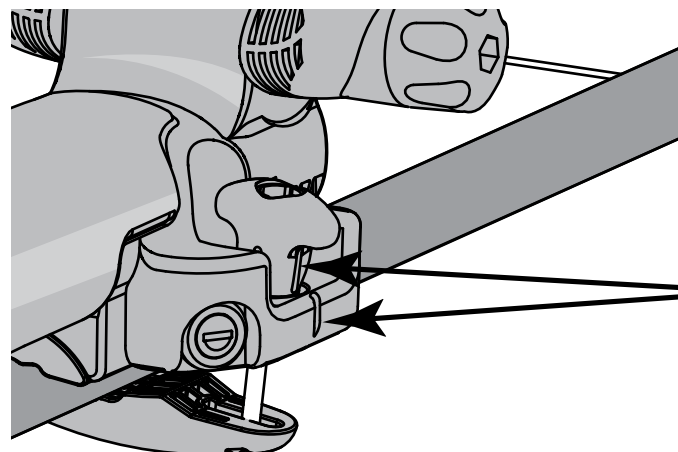

Alinear

ATE LAS AMARRAS DE PROA Y POPA.

- 10** Ate la correa con hebilla a la embarcación.

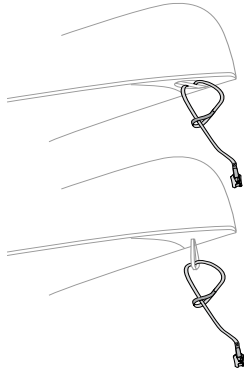

Ate la correa a la manija de agarre o a la barra de rescate y tire firmemente.

- 11** Pase la correa plana por el ojal del gancho.

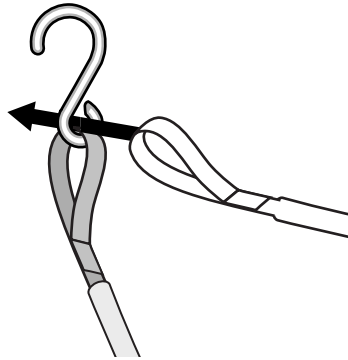

- 12** Use el gancho para enganchar la correa en alguna parte metálica del paragolpes, en el gancho de remolque o en algún agujero de la carrocería.

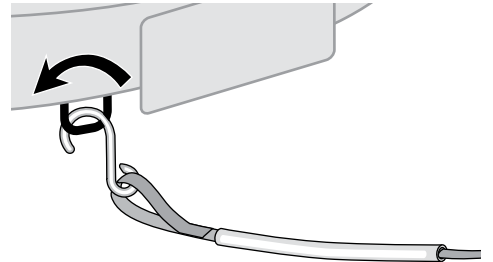

- 13** Deslice el tubo de plástico para proteger el vehículo en el punto de contacto.

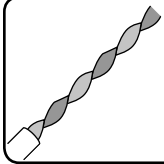

NOTA: Retuerza la correa para reducir la vibración debida al viento.

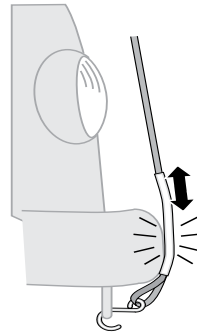

- 14** Inserte el extremo de la correa plana en la hebilla.

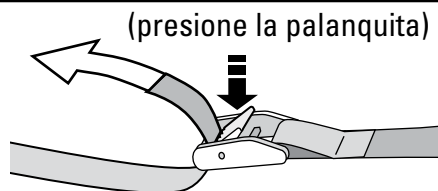

- 15** Ajuste la tensión de la correa tirando del extremo libre.

- Aplique una presión uniforme en las correas de la parte delantera y trasera.
- Enrosque y ate todo exceso de correa que pudiera quedar.

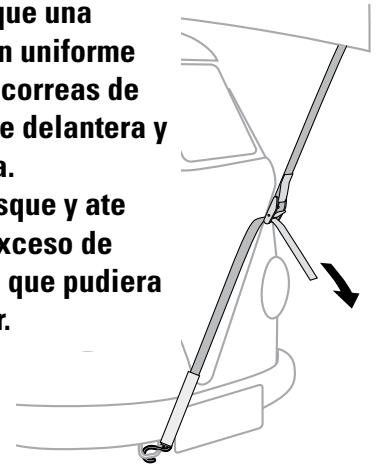

La falta de una fijación adecuada en la parte delantera y trasera de una carga larga a los extremos del vehículo, puede provocar daños materiales, heridas corporales o la muerte.



Verifique las correas periódicamente durante un viaje y apriételas en caso de necesidad. Reemplace toda correa que esté gastada o deshilachada antes de utilizarla (consulte un representante de Yakima).

Ahora que ya instaló su BowDown, tómese un momento para gozar su trago preferido.

Utilice el destapador de botellas incorporado para destapar una bien fría.

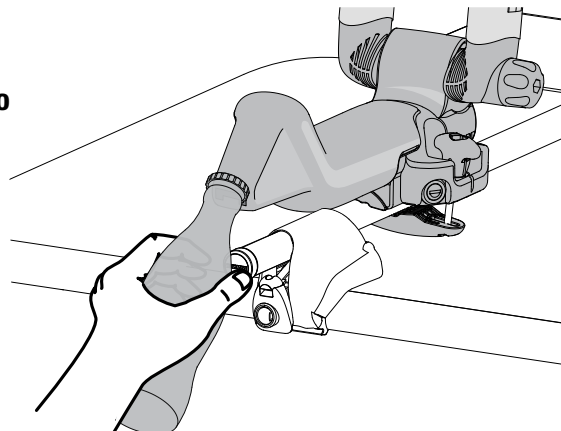

- No beba alcohol mientras conduce.
- No beba alcohol sobre una embarcación.



ANTES DE SALIR DE VIAJE:

- Verifique el movimiento meciendo la embarcación.
- Ajuste nuevamente si hay indicios de movimiento.
- Asegúrese de que la perilla está apretada.
- LEA TODAS LAS PRECAUCIONES Y LIMITACIONES.

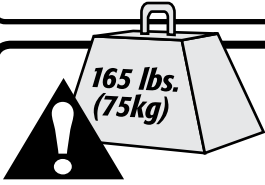

LÍMITES DE PESO

Respete la lista de compatibilidad de Yakima, o visite el sitio Yakima.com para conocer el límite de peso de su bastidor. No exceda el límite de peso de los bastidores para su vehículo.

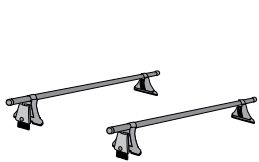

BASTIDOR

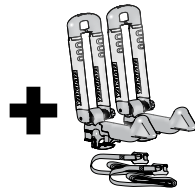

ESTE PRODUCTO

(16 lbs. / 7.3 kg)

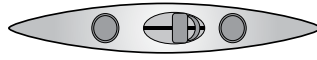

CARGA



No más de 165 lbs
(75 kg), a menos que se
indique lo contrario.

*(Ciertos vehículos están clasificados para menos de 165 lbs. (75 kg)).

SI RETIRA SU PORTAEQUIPAJE, SIGA LAS INSTRUCCIONES PARA INSTALARLO NUEVAMENTE.

Respete las consignas de seguridad incluidas en las instrucciones de los accesorios antes de cada instalación.

PORTEZUELA TRASERA

Algunas cargas largas pueden impedir que la portezuela trasera se abra completamente.

ABRA SIEMPRE LA PORTEZUELA CON CAUTELA.

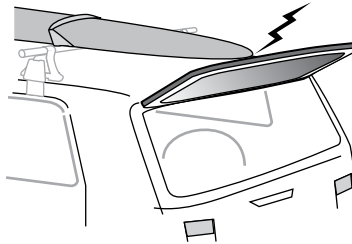

ANTENA

Quizá sea necesario quitar la antena del techo para evitar interferencia con las cargas largas.



ATENCIÓN: CERCÍOARSE DE QUE TODO EL EQUIPO ESTÁ ASEGURADO SEGÚN LAS INSTRUCCIONES. LAS PIEZAS DE MONTAJE PUEDEN AFLOJARSE CON EL TIEMPO. VERIFIQUE ANTES DE CADA USO Y AJUSTE SI ES NECESARIO.

MANTENIMIENTO: Use un lubricante no soluble en agua en los tornillos. Use un paño blando con agua y detergente suave para limpiar las partes plásticas.

QUITTE LOS ACCESORIOS ANTES DE ENTRAR EN UN LAVADERO AUTOMÁTICO DE VEHÍCULOS.

SI NECESITA ASISTENCIA TÉCNICA O REPUESTOS

Contacte un vendedor, visite el sitio www.yakima.com o llame al (888) 925-4621.

De lunes a viernes,
de 7:00 AM a 5:00 PM, hora del Pacífico.

GARANTÍA LIMITADA A VIDA "MIENTRAS DURE EL ROMANCE"

Este producto está cubierto por la garantía limitada a vida "mientras dure el romance" de Yakima. Para obtener una copia de esta garantía, visítenos en www.yakima.com, envíenos un correo electrónico a yakwarranty@yakima.com o llámenos al (888) 925-4621.

LOVE IT TILL YOU LEAVE IT
LIFETIME
WARRANTY

¡ CONSERVE ESTAS INSTRUCCIONES !