

Heavy Duty Yoke Puller

MODEL 40314

ESCO

PRO
SERIES

NEW
ARRIVAL!



Designed to withstand rigorous and daily usage in any environment, capable of generating over 25,000 lbs. of pulling force using a one-inch impact.



BENEFITS & FEATURES:

- ▶ Safe & Fast solution for the removal of commercial yokes, driveshafts, transmissions and rear-end differentials.
- ▶ Generates up to 25,000 lbs. of pulling force.
- ▶ Designed to be use with up to a 1 inch. impact tool.
- ▶ Made of high quality heavy duty steel capable of withstanding rigorous and daily use in shop environments.
- ▶ Application: Commonly found on class 6-8 transportation trucks and equipment.

(More Details on Back)

Specifications:

MODEL 40314

The **ESCO Heavy Duty Yoke Puller - For Spicer & Meritor 1610, 1760, 1810 (MODEL 40314)** streamlines the removal of heavy-duty commercial yokes on driveshafts, transmissions and rear-end differentials, while eliminating any potential for damage to yokes or other components by using other methods of removal. Manufactured with heavy-duty commercial high-grade steel, the ESCO Heavy Duty Yoke Puller is designed to withstand rigorous and daily usage in any environment, capable of generating over 25,000 lbs. of pulling force using a one-inch impact. Universally designed to handle a wider range of 6-8 class transportations vehicles and comes complete with transportation case for easy storage.

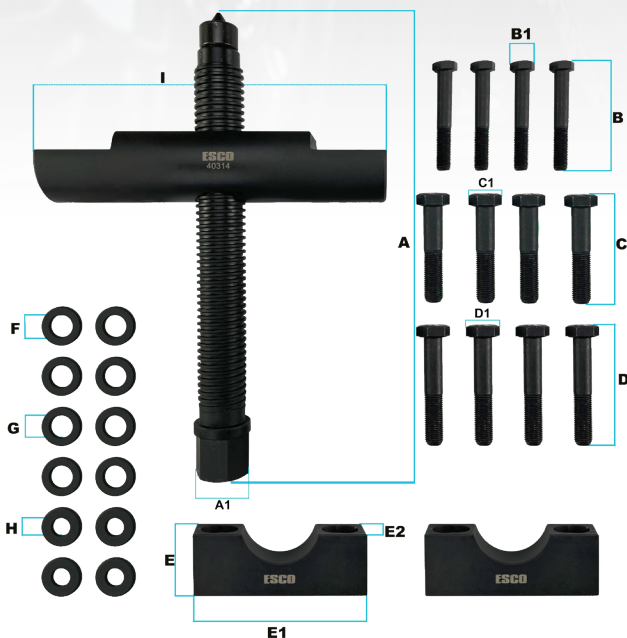

SPECIFICATIONS:

A	11 in.	E	1 1/2 in.
A1	1 1/4 in.	E1	4 1/8 in.
B	2 11/16 in.	E2	13/16 x 11/16 in.
B1	5/8 in.	F	5/8 in.
C	2 11/16 in.	G	5/8 in.
C1	3/4 in.	H	1/2 in.
D	2 11/16 in.	I	8 in.

Drive Size [in.]	1 1/4 in.
Weight [lbs.]	13.7 lbs.
Product Dimensions (L x W X H)	See specifications above
Packaging Dimensions (L x W X H)	12 x 13.5 x 3 in.

Material	CR-MO (Chromium-Molybdenum) alloy steel
-----------------	---

Application	Application Commonly found on class 6-8 transportation trucks and equipment.
--------------------	--

UPC	816904025151
Warranty	Limited Lifetime

NOTE: ESCO reserves the right to change, alter, or modify product(s) without notice. This includes but is not limited to product: color, design, parts, accessories, etc.

sales@esco.net **WWW.ESCO.NET** 1.800.352.9852



COPYRIGHT 2022 • 15270 Flight Path Drive • Brooksville, FL 34604

