

OPERATION & SERVICE MANUAL

SL SERIES SEMI-ELECTRIC STACKER WITH MANUAL DRIVE & POWERED LIFT



Vestil Manufacturing Corp.
2999 North Wayne St., Angola, IN 46703
Ph: 260-665-7586 . Fax: 260-665-1339
E-mail: Sales@vestil.com
Website: www.vestil.com

CONTENTS

General	3
Specification	4
Receiving instructions	5
Safety Notes	6
Product description	7
Designated use	7
Signs on the Truck	8
Removing from the pallet	9
Operation	10
Operation	
Operating elements	11
Lifting and lowering	12
Parking Brake	13
Lifting & Transporting the load.....	14
Maintenance and repair	15
Trouble shooting	15-16
Changing batteries	17-18
Maintenance daily/before use, monthly, annually	19
Maintenance and care of the load chains	20
Chain inspections	21
Temporary lay-up	22
Warranty	23
Parts drawing & Parts list	24-32

Introduction

Read and follow the instructions contained in this operating manual.

Only trained, well-informed personnel, who have been instructed in accordance with this operation manual, may use or work on the stacker.

Liability or guarantee is waived if:

- The instructions in this operating manual are not observed.
- The high-lift stacking truck is operated, cleaned or maintained incorrectly.
- Alterations to the functions are carried out without the consent of manufacturer.
- Original spare parts are not used.

Safety instructions

This chapter informs the user about residual dangers relating to the correct use of the products. It contains generally valid safety instructions which must be observed.

Safety instructions relating to specific actions or situations are listed prior to the respective action and/or description of the situation in the chapter.

Principles

This product complies with state-of-the-art technical standards and recognized safety regulations, but there are still dangers which may occur which must be considered.

Only operate the product in a perfect condition and observing the information contained in the operating manual.

The operator is responsible for integrating the product with as little risk as possible into his working environment. This obligation continues through every phase of the products lifespan, beginning at the planning stage. Residual dangers are to be minimized.

Only trained, competent personnel who have been instructed using the operating manual and the product are permitted to work with the truck.

The operating manual must be understood (responsibility, checking)

Declaration:

I have read this manual and, in particular, have taken note of the caution.

Name	Date	Signature

Specification

SPECIFICATION

	SL-63-AA/FF	SL-118-AA/FF	SL-137-AA
Capacity	2000 lbs.	2000 lbs.	2000 lbs.
Fork Lift Height	62"	118"	137"
Capacity	2000 lbs. @ 62"	1500 lbs (62"-118")	b)1500 lbs. @ (62-118") c)1000 lbs. @ (118-137")
Fork Dimension			
FF	42x5.9 x2 3/8"	42x5.9x2 3/8"	None
AA	42x4 x1 1/4"	42x4 x1 1/4"	42x4 x1 1/4"
Overall Fork Width	26 3/4"	26 3/4"	26 3/4"
Ground Clearance	1"	1"	1"
Lowered Fork H.			
FF	3 1/4"	3 1/4"	None
AA	2 1/8"	2 1/8"	2 1/8"
H. Overall Extended	81 7/8"	140"	159"
Head Dimension	29 1/8x19 5/8x37"	29 1/8x19 5/8x37"	29 1/8x19 5/8x37"
Loading Center	21"	21"	21"
Wheel Base			
FF	39 3/4"	39 3/4"	None
AA	40 1/2"	40 1/2"	40 1/2"
Turning Radius	51"	51"	51"
Steering Wheel	Φ7x2"	Φ7x2"	Φ7x2"
Front Wheel			
FF	Ø3x3 1/4"	Ø3x3 1/4"	None
AA	Ø4x2.9"	Ø4x2.9"	Ø4x2.9"
Overall Size			
FF	67 5/16x29 1/8x81 7/8"	67 5/16x29 1/8x81 7/8"	None
AA	66 1/8x29 1/8x81 7/8"	66 1/8x29 1/8x81 7/8"	66 1/8x29 1/8x877/8"
Lift Speed			
Speed	Load	2.74"/s	2.95"/s
	Unload	4.84"/s	4.72"/s
Lower Speed	Load (1 spd.)	2.42"/s	2.45"/s
	Load (2 spd.)	4.5"/s	4.53"/s
	Unload (1 spd.)	2.42"/s	2.45"/s
	Unload (2 spd.)	4.2"/s	4.21"/s
Lift Motor	12V/1.5KW	12V/1.5KW	12V/1.5KW
Amperage (Loaded)	165 amps.	165 amps.	177 amps.
Amperage (Unloaded)	65 amps.	105 amps.	107 amps.
Battery	12V/140Ah	12V/140Ah	12V/140Ah
Battery Charger	12VDC/5A	12VDC/5A	12VDC/5A
Weight			
FF	830 lbs.	1020 lbs.	None
AA	870 lbs.	1070 lbs.	1140 lbs.
Width of Aisle	72"	72"	72"

FF: FIXED FORKS OVER SUPPORT LEGS

AA: ADJUSTABLE FORKS OVER ADJUSTABLE LEGS

Note: The load capacity is based on the situation when the center of the gravity is located at the center of length of forks. When the center of gravity of goods is out of the center of forks, the load capacity will be lessened compared to the center.

Receiving Instructions

Every unit is thoroughly tested and inspected prior to shipment. However, it is possible that the unit may incur damage during transit. If you see damage when unloading, make a note of it on the SHIPPER RECEIVER.

Remove all packing & strapping material, inspect for damage. IF DAMAGE IS EVIDENT, FILE A CLAIM WITH THE CARRIER IMMEDIATELY! Also, check fork size, type of power unit, etc., to see that the unit is correct for the intended application.

Warnings & Safety Instructions

Insure that all employees understand and follow the following instructions

- Read and understand the owner's manual before using or servicing the stacker.
- Do not use the stacker if any damage or unusual noise is observed.
- Improper use of this lift truck could result in injury and damage to load or equipment.
- Always watch the stacker and any load on it carefully when it is being used or moved.
- DO NOT load beyond rated capacity.
- DISTRIBUTE load evenly
- Avoid sudden stops or quick turns to prevent accidental tipping of the load.
- Load must be centered and evenly distributed on the forks.
- Park the truck on level surfaces and not in the way of other products
- When parked, lower the load fork completely.
- When parked, push E-switch push-button down.
- Do not perform any modifications to the stacker without the manufacturer's approval. Failure to receive authorization for changes to the equipment could void the warranty.
- Do not use brake fluid or jack oil in the hydraulic system. If oil is needed, use an anti-wear hydraulic oil with a viscosity grade of 150 SUS at 100°F, (ISO 32 @ 40°C), or a non-synthetic transmission fluid.
- Use only replacement parts either supplied or approved by the manufacturer.

Safety notes

Symbols and pictures

In addition to the text and illustrations, this operating manual contains various symbols which should draw attention to the safety requirements.











They generally have the following appearance:

Signal wording	Explanation
DANGER	Warning of an imminent danger! Non-observance cause death or serious injury
WARNING	Warning of a possibly incoming dangerous situation. Non-observance may cause death or serious injury.
CAUTION	Warning of a possibly incoming dangerous situation. May also be used for warnings of major damage to property.

Other definitions:

DIRECTION	Marks recommendations for use and other useful information. Does not warn of dangerous situations.
IMPORTANT	Warns of a harmful situation. Non-observance may cause damage to material.

USE SYMBOLS & PICTURES

	Possible danger to file and limb or machine!		Do not step onto when load is raised!
	Danger of crushing!		It is forbidden to ride on the truck!
	Do not reach into running motor!		Suspension points for transport of truck!
	Wear safety shoes		Important
	Wear helmet		Suspended warning! load

Product description

Designated use

- ❖ The stacker is designated for lifting, lowering and transportation of loads according to the specifications of the identification plate.
- ❖ The stacker is to be used on hard level surfaces.
 - To move the stacker between buildings, warehouses etc
 - The gradient of the slope is 0%
 - Make sure load is not loose or unstable.
 - Do not pick up loads on tips or forks or edge of platform.
 - Do not overload.
 - The road surfacing must be solid and have a good grip.
- ❖ Travel routes must offer sufficient load-bearing capacity for the loaded truck.
- ❖ The stacker is not suitable for continuous use in cool-houses!

Ambient conditions				
Temperature	From To	14 113	° F ° F	
Degree of humidity		≤70	%	
Permitted floor incline				
• Loaded		Max. 0	%	
• Unloaded ¹		Max. 0	%	
Dimensions and weights				
Mass (dead weight)	m	1058/1653	lbs	



WARNING!

The user is responsible for determining the actual load bearing capacity of a high-lift stacking truck. This can depend on the user, the condition of both the floor and the high-lift stacking truck and the regularity of the maintenance intervals.

Product description

Signs on the Stacker



Removing from the pallet



CAREFUL

To pick up the unit only use overhead hoist, or forklift with sufficient carrying capacity & take into consideration the center of gravity of the unit. Use top crossmember to lift the equipment. Be careful of the stacker swinging once fully lifted off the pallet or skid. Remove the pallet or skid from below the lift & lower the stacker on the ground.

Refer to the identification plate for the weight of stacker.



Lifting belt specification— Use polyester lifting sling or nylon sling and hoist with a minimum of 2,000 lb. capacity.



DANGER

When unloading the truck, all personnel should be cleared from the area.

OPERATION

Visually inspect stacker for damaged and worn parts, before stacker is taken into operation. Authorized person should read and understand all instructions

The lifting truck is ready for immediate use once the packaging has been removed.

- ◆ The battery is full and charged.
- ◆ The hydraulic tank is full.
- ◆ The steering roller and the running rollers are equipped with bearings which do not require maintenance; all mast rollers are also free from maintenance.



Caution!

Pedestrian controlled industrial trucks may only be operated by persons who have been satisfactorily instructed in operating the truck and have proved their ability to operate the truck to the responsible representative of the operating company.

The first driving attempts should take place on level and spacious surfaces.

Recommendation:

The operator who is to maneuver the truck and is to control the lifting mechanism should be allowed to practice, when unloaded, until they can safely operate these functions.

Only then should they undertake the loading, transporting and unloading of load.

Operation
Operating Elements

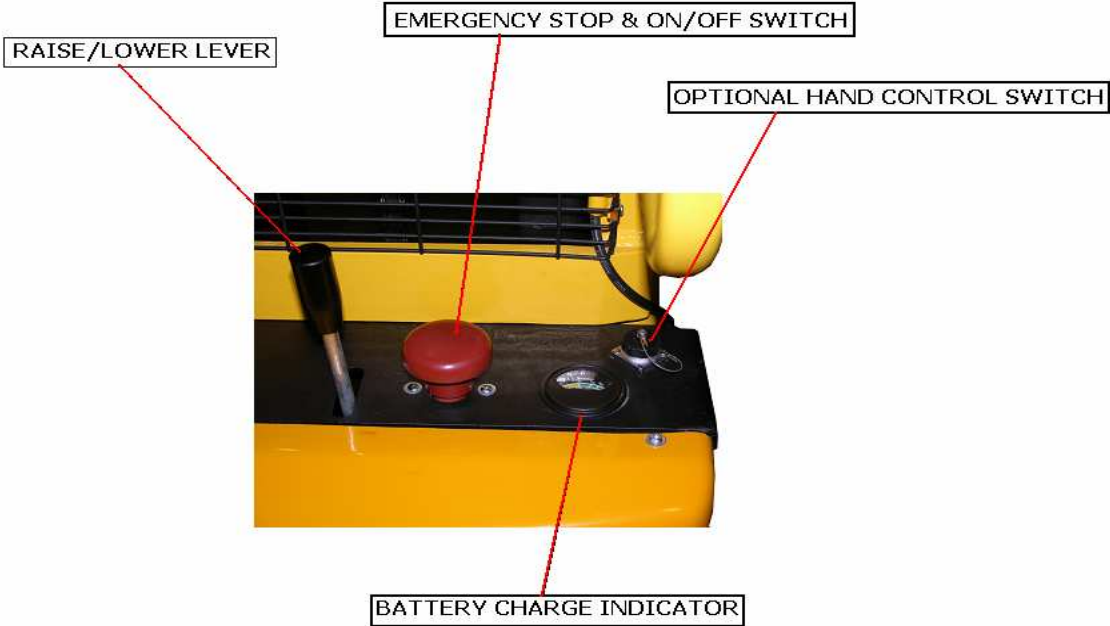

To raise and lower

The following are generally valid for the lifting and lowering procedure:

- The red operating button of the EMERGENCY STOP pushbutton must be pulled upwards
- Lifting and lowering movements are initiated by pushing & pulling a lever on the power unit.



Operation

Parking Brake:

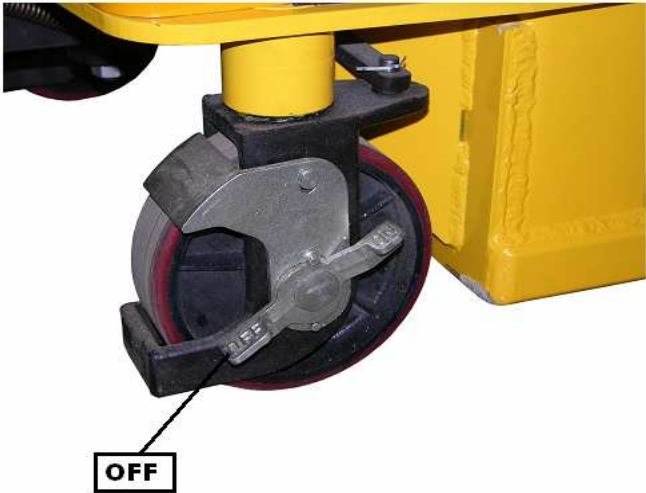

To activate the parking brake, press down on the brake pedal

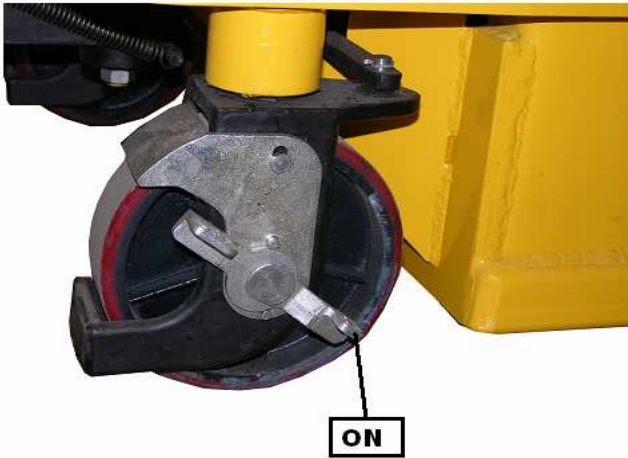

To release the parking brake, press down on the brake pedal

Operation

Lifting the load



CAUTION!

- Before lifting a load to be transported, ensure that the load does not exceed carrying capacity of the stacker.
- The nominal carrying capacity and lifting heights can be viewed in the load diagram.
- Ensure that the load can be lifted up in a compact and stable manner. Slipping or falling of the load must be avoided.
- Load must not project into the lifting frame.
- Load must be centered and evenly distributed on the forks.
- The load must not extend more than 2" over the end of the forks.



Transporting the load



CAUTION!

- Raise the load slightly (3") above the ground to transport
- For safety reasons (view) transport only in a forward direction
- Only when lifting or lowering down the load it is permissible to move the stacker forward or in reverse with a raised load
- Lift up or lower down the loads on level surface
- When unloaded, move stacker only with forks lowered.

When stacker not in use

- Park the stacker on a level surface
- Lower down the forks completely
- Push down ON/OFF switch



Maintenance and repair

TROUBLESHOOTING GUIDE --

Warning: Before performing any task, always block drive wheel off of the ground.

Consult the factory for problems at time of installation, or for any problems not addressed below.

<u>Problem:</u>	<u>Possible cause(s):</u>	<u>Action:</u>
Unit will not charge	Charger malfunction Bad batteries	Verify output voltage on charger, will only get a reading when connected to batteries; should be approximately 28 volts. Load test batteries
Unit will not raise; motor does not run	Loose wire Bad solenoid Upper limit switch out of adjustment Blown fuse Batteries discharged	Verify 24 volts at coil when raise is pushed, if no voltage; trace wiring back to tiller head looking for voltage on each side of the connectors until the bad connection is found. If voltage is present at the solenoid and the unit does not rise, remove the two wires to the coil and measure the coil resistance. It should be around 19 ohms. If it's open, or shorted replace the solenoid. Bypass upper limit switch and see if the unit raises...DO NOT TAKE IT ALL THE WAY UP... If it does rise, verify the limit switch is normally closed and will open when activated. If the limit switch is ok, try to adjust the switch accordingly so that the units raise height is approximately 7 to 8" Check fuses above motor controller Re-charge batteries
Unit will not raise; motor runs	Lower solenoid stuck on No hydraulic oil	Check to see if the lowering switch is stuck on. If it is, remove the tiller head via 3 screws on bottom and replace switch, or tap on switch to see if it can be freed up. Re-fill hydraulic oil
Unit will not lower	Loose wire; bad coil	Verify 24 volts at coil when lower is pushed, if no voltage, trace wiring back to tiller head looking for voltage on each side of the connectors until the bad connection is found. If voltage is present at the coil and

	Upper limit switch out of adjustment	<p>the unit does not lower, remove the connector to the coil and measure the coil resistance. It should be around 39 ohms. If it's open, or shorted replace the coil.</p> <p>Loosen hydraulic line at pump to relieve pressure build up. Re-adjust limit switch so unit stops at 7 to 8 inches above the ground.</p> <p>Look for binding in chain or rollers</p>
Unit keeps blowing fuses when the raise lever is pressed	Shorted solenoid for motor raise	Remove the wire to the solenoid coil on the pump motor. Measure the resistance; it should be around 19 ohms. If it is nearly zero ohms replace the solenoid.
Lifting height is not longer achieved	Hydraulic oil level is too low	Re-fill hydraulic oil when forks are lowered.
Unit jerks when lifting	Air in the system	Open vent screw on the lift cylinder with forks lowered all the way down. Lift forks with vent screw open until oil is free from air bubbles. Close the vent screw
Forks raise, then drift down	Check valve or Solenoid valve leaking (contamination holding open the lowering valve or the check valve)	<p>Remove & inspect.</p> <ul style="list-style-type: none"> . Remove any load from the forks. . Remove the nut holding solenoid coil on the valve stem, and then unscrew the valve from the manifold. . Inspect the valve for contaminants, and the valve's o-rings and back-up washers for cuts, tears, and other damage. . With valve immersed in mineral spirits or kerosene, use a thin tool such as a small screwdriver or a small hex wrench to push the poppet in and out several times from the bottom end of the valve. The valve should move freely, about 1/16" from closed to open position. If it sticks in, the valve stem could be bent and will need to be replaced if it doesn't free up after cleaning. <p>Blow the valve off with a compressed-air gun while again pushing the poppet in and out.</p>

Instructions for Changing the Batteries, estimated time, 15 min.

READ ALL INSTRUCTIONS BEFORE PROCEEDING!
Only qualified personnel should work on this equipment!

Lock out all potential energy sources before attempting this installation; turn off the unit.

Warning!

- ! Working with or near lead acid batteries is dangerous. Batteries contain sulfuric acid and produce explosive gases. A battery explosion could result in loss of eyesight or serious burns.
- ! Do not smoke or allow a spark or flame near batteries. Charge batteries in locations which are clean, dry, and well-ventilated. Do not lay tools or anything metallic on top of any battery. All repairs to a battery must be made by experienced and qualified personnel.
- ! When working with batteries, remove personal items such as rings, bracelets, necklaces, and watches. Batteries can produce enough energy to weld jewelry to metal, causing a severe burn.
- ! Always have fresh water and soap nearby in case battery acid contacts skin, clothing, or eyes.
- ! Operating the battery with a low battery voltage can cause premature motor contact failure.
- ! Do not expose the lift or charger to rain or adverse conditions.
- ! Replace defective cords or wires immediately.
- ! Check the battery's water level frequently if this applies to your battery type.
- ! Make sure the battery charger is unplugged from 115vac source.

Battery Charger Operating Instructions

Plug the charger into a standard 115V receptacle. If an extension cord must be used, keep it as short and as large as possible. A small cord will decrease the output of the charger due to the voltage drop in the line. This will increase the charging time. It can also cause the 115V cord to overheat.

When properly connected, the charge LED will indicate the status of charge current flowing to the battery, as follows: Power LED is always green when charger is plugged in. The status light is as follows:

Red only – the charger is providing full output to the battery.

Yellow – the charger is “topping off” the battery.

Green – the charger is providing a “float,” or maintenance, charge.

Remember to unplug the charger before moving the equipment. Failure to do so could cause damage to cords, receptacles and other equipment.

Troubleshooting:

If the unit does not operate, check all of the wiring connections to make sure they're both mechanically and electrically sound – specifically at the battery, and the motor.

A fully-charged lead acid battery in good condition at room temperature should read 12.65 volts. At 11.9 volts it is considered to be fully discharged and in need of charging. When checking battery voltage, wait at least 1\2 hour after the charger has been turned off before checking the battery's voltage.

If the batteries aren't being charged by the charger, check the output charger fuse. Verify fuse is good with an ohmmeter, or close visual (ohm meter best). Fuse is a 10Amp 250 Volt; GBD 10A. If it is good, check the battery's state of charge with a voltmeter. The charger must be connected to the battery in order to read the output voltage of the battery charger. Depending on the state of charge of the batteries, the voltage should be somewhere around 27 to 28 volts dc.

If it is determined the batteries are dead, and need replaced, change the batteries.

Tools Required:

14mm wrench, or crescent wrench

Regular flat bladed screw driver

Maintenance and repair

(A) BEFORE EACH USE INSPECT FOR THE FOLLOWING:

- 1) Frayed wires
- 2) Oil leaks
- 3) Pinched or chafed hoses
- 4) Damage or structural deformation to the structural members, the cylinder brackets, etc.
- 5) Unusual noise or binding, or evidence thereof.
- 6) Proper functioning of all limit switches, including those on the perimeter pinch point guard (if applicable)
- 7) Load chain, check for mechanical damage, check for play (slack in chain)
- 8) Battery, keep the surface of battery clean and dry. Make sure battery is secured against slipping

(B) INSPECT MONTHLY FOR:

- 1) The oil level. Oil should be 1-1/2" to 2" below the reservoir's fill hole with the lift in the fully raised position
- 2) Worn or damaged hydraulic hoses and electrical wires
- 3) Pivot point wear
- 4) Roller's looseness and wear
- 5) Integrity of retaining rings on all the rollers and at all pivot points
- 6) Looseness, wear, or damage to the front rollers & drive wheel, bearings, mounting hardware, or surface material
- 7) Proper functioning of any hand-or foot-operated mechanisms
- 8) Proper water level in the battery
- 9) Unusual noises or movement during operation
- 10) All the information, safety, and wearing labels being in place and in good condition
- 11) The need to clean off dirt and debris

(C) YEARLY INSPECTIONS

- 1) The oil should be changed if the oil darkens, becomes gritty, or turns a milky color (indicating the presence of water). Replace with anti-wear hydraulic oil with a viscosity grade of 150sus at 100°F, (ISO 32 at 40° C). Ex:AW 32 or HO 150 hydraulic oil, or a non-synthetic transmission fluid. You may use a synthetic transmission fluid if you flush the system with the synthetic fluid before filling the reservoir.
- 2) Check chain and chain connections for any mechanical damage
- 3) Clean upright channels and mast rollers, & grease slightly.
- 4) Check magnetic brake travel, & if necessary change brake rotor
- 5) Check carbon brushes for any wear in the lift motor, & if necessary change carbon brushes.

Maintenance and repair

Maintenance and care of the load chains

In normal use the load chains should be re-lubricated every 250 operating hours; in the event of heavy soiling, moisture and very high prolonged loading, re-lubrication should be effected after 100 operating hours. If subject to corrosive media the chain should be cleaned and lubricated immediately.

Chain lubrication, chain conservation

Flyer chains are correctly lubricated and are in a perfect state if:

The chain is free of exterior soiling.

When touching the chain, your finger is wetted with oil. This assures that the lubrication of the chain links is sufficient.

Type of lubricant

A low-viscosity mineral – machine – or engine oil or synthetic oil should be used. The viscosity of the lubricating oil is to selected so that it remains low viscose at all ambient temperatures encountered.

Under normal temperature conditions, lubricating oils with a viscosity of SAE 20 to SAE 40 would be appropriate.

Lubricating methods

The lubricant can be applied by means of brush, paint brush or also using compressed air spray devices. When using spray cans, please make sure the following basic requirement is fulfilled:

- After the thinner has vaporized, a viscosity conforming to the above-mentioned recommendation (type of lubricant) must be met.

Cleaning the chain

If operation leads the chain to suffer so heavily from soiling that the penetration of the lubricating oil cannot be guaranteed, the chain must be cleaned.

This is only to be effected with paraffin derivatives such as diesel fuel, petroleum, cleaner's naphtha etc.

Do not clean with steam injectors, cold cleaners or even corrosive and acidic substances. They can directly lead to chain damage.

If the chains have to be cleaned with steam injectors, please contact our customer service.

Maintenance and repair

◆ Chain inspections

Chains used in stackers should be inspected at least once a year or every three months if exposed to severe contamination or high continuous loading stress.

We recommend that attention be paid to the following points:

1. Unusual noise
2. Surface rust
3. Linkage rust
4. Stiff links
5. Distorted pins
6. Loose link pins
7. Damage
8. Broken link plates
9. Broken pins
10. Contamination
11. Stretching

Even with the optimum amount of lubrication, it is impossible to prevent a chain from stretching.

Wear extends only to that part of the chain which is led over the chain sprocket/guide sprocket. Thus, when checking for wear, only check the area need be inspected.

According to the regulations currently in force, a chain is deemed to be worn if it has stretched by 3%.

If safety issues are particularly critical or a potential hazard is dependent on a single chain, we consider it necessary to replace it if it is stretched by even 2%.

Measuring procedure

To measure elongation through wear, that part of the chain which runs over the chain sprocket/guide sprocket must be positioned in the stretched area. With the aid of a measuring rod, measure a section approximately 1 meter in length. The number of divisions in the measured area, multiplied by the chain divisions, gives the nominal measurement. The length extending beyond this measurement represents the wear, which is limited to a maximum of 3% over the nominal length.

An elongation through wear of 3% is reached if 33 links of the chain in use measure the same length as 34 links of a new chain.

◆ Chain replacement

If two chains are used as a pair on the affected machine, both should always be changed at the same time.

The installation and removal of chains should be carried out with all the care appropriate to any item of safety equipment.

Chains may only be repaired by authorized specialist personnel.

We do not recommend the lengthening of safety-type lifting chains, since the inserted chain link will not have been pre-stretched.

Our product liability will be invalidated if a repaired chain is assembled from sections bearing different silver label numbers.

Maintenance and repair

◆ Temporary lay-up

If, for operating reasons, the stacker is laid up for more than two months, the following instructions are to be carried out:

- * Place the stacker on blocks so that all the wheels are raised from the floor.
In this way, they will be prevented from becoming permanently misshapen.
- * Clean the stacker thoroughly.
- * It may be necessary to support the lifting gear in a suitable manner, so as to relieve any stress on the load chains.
- * Check the hydraulic fluid level, replenish if necessary.
- * Grease the stacker thoroughly.
- * Clean all bright and moving parts with a thin film of oil and grease respectively.
- * Store the stacker in a dry, frost-proof, dust-free place.
- * Do not use plastic sheeting to cover the stacker otherwise condensation could form under it.

Additional operations for vehicles with integral electrical systems

- * Disconnect the batteries from the stacker electrical system.
- * Charge the batteries.
- * Clean the top of the battery case and terminals.
- * Grease the terminals lightly with terminal grease.
- * Check the electrolyte level, top up if necessary (not applicable to maintenance-free or gel batteries).
- * Recharge the batteries every 90 days; gel batteries every 6 months.
- * Spray a suitable contact spray on unattached electrical contacts.

Return to service after a lay-up

- * Thoroughly clean and grease the stacker.
- * Remove the film of protective grease.
- * Check the hydraulic fluid tank and hydraulic fluid for condensation, if necessary carry out a fluid change.
- * Inspect hydraulic hose lines for brittleness.
- * Test the functions of the vehicle, particularly the safety equipment.

Serial No. _____

Model: _____

LIMITED WARRANTY

Vestil Manufacturing Corporation (Vestil) warrants each model SE/HP, S-CB, SL-series or S-series Stacker to be free of defects in material and workmanship during the warranty period. Our warranty obligation is to provide a replacement for a defective original part (a part used to make the product as shipped to the warrantee) after we receive a proper request for warranty service. "Proper request" means that we must receive: 1) a photocopy of your Customer Invoice that displays the shipping date; AND 2) a written request for warranty service that includes your name and phone number. Send requests by any of the following methods:

Mail

Vestil Manufacturing Corporation
2999 North Wayne Street, PO Box 507
Angola, IN 46703

Fax

(260) 665-1339

Phone

(260) 665-7586

Email

sales@vestil.com

In the written request, list the parts you believe are defective and include the address where replacements should be delivered. After Vestil receives your request, an authorized representative will contact you to determine whether your claim is covered by the warranty (also see "If a defective part is covered..." below). Before providing warranty service, Vestil may require you to send the entire product or the defective part or parts to its facility in Angola, Indiana.

Who may request service?

Only the warrantee may request service. *You are a warrantee if* you purchased the product from Vestil or from an authorized distributor AND Vestil has been fully paid.

What is covered under the warranty?

The warranty covers the following *original* drive and lift components: drive motors and lift motors, hydraulic pumps, electronic controllers, switches and cylinders. It also covers *original* parts that wear under normal usage conditions ("wearing parts"): bearings, hoses, wheels, seals, brushes, batteries, and the battery charger. The warranty period for drive and lift components is 1 year. For wearing parts, the warranty period is 90 days. Both warranty periods begin on the date when Vestil ships the product to the warrantee. If you purchased the product from an authorized distributor, the periods begin when the distributor ships the product, which extends the warranty by up to an additional 30 days.

If a defective part is covered by the warranty, what will Vestil do to correct the problem?

Vestil will provide an appropriate replacement for any *covered* part. An authorized representative of Vestil will contact you to discuss your claim.

What is not covered by the warranty?

1. Labor costs or Freight;
2. Any of the following automatically void the warranty:
 - Product misuse;
 - Negligent operation or repair;
 - Corrosion or use in corrosive conditions;
 - Inadequate or improper maintenance;
 - Failure to exercise good judgment;
 - Damage sustained during shipping;
 - Accidents involving the product;
 - Unauthorized modifications: Do NOT modify the product IN ANY WAY without first receiving written authorization from Vestil. Modifications may render the pallet truck or stacker unsafe to use or might cause excessive and/or abnormal wear.

Do any other warranties apply to the product?

Vestil Manufacturing Corp. makes no other express warranties. Any warranty implied-by-law is limited in duration to the warranty period.



PARTS DRAWING & PARTS LIST

Electric wiring diagram

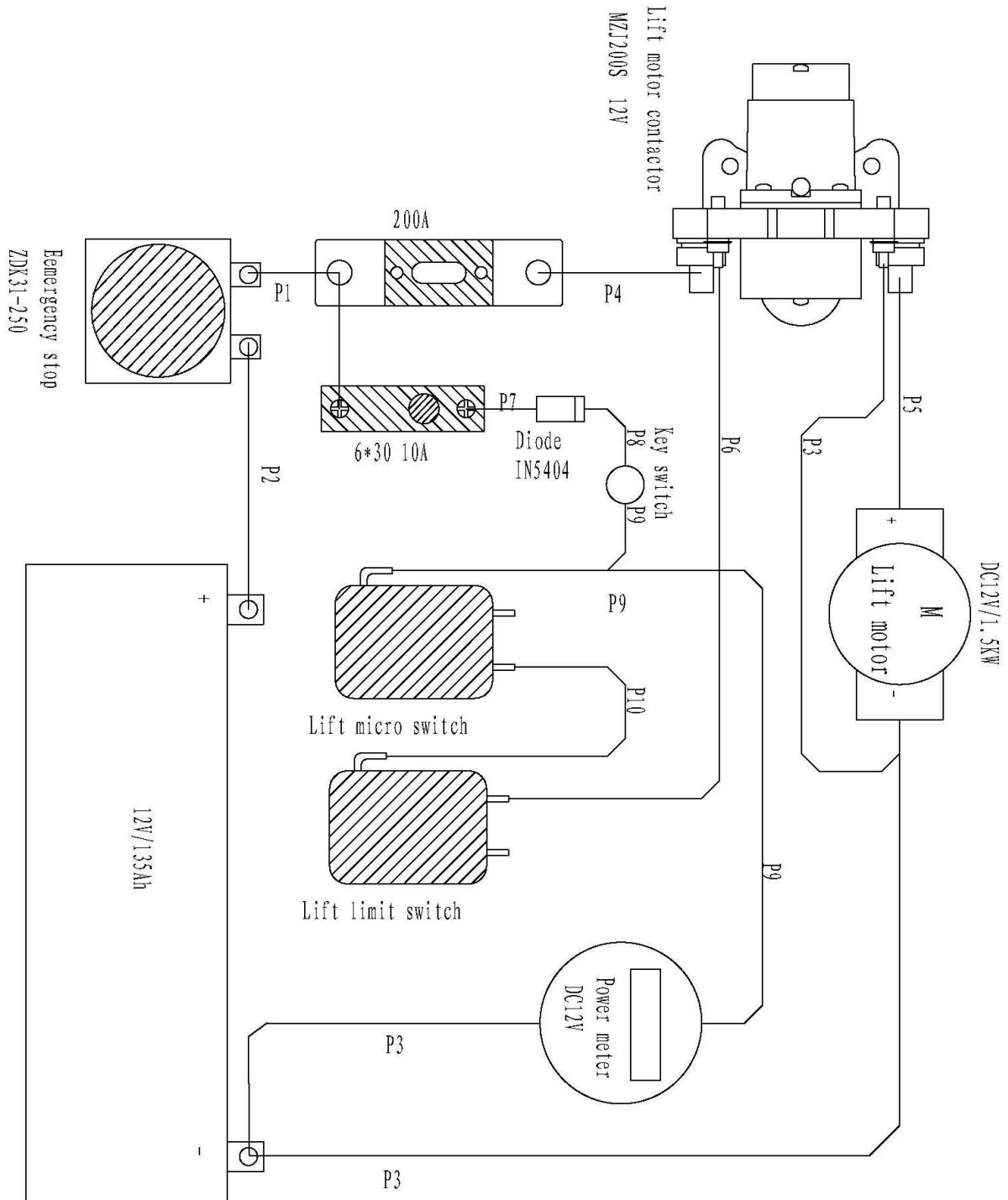

Electric circuit diagram and component list

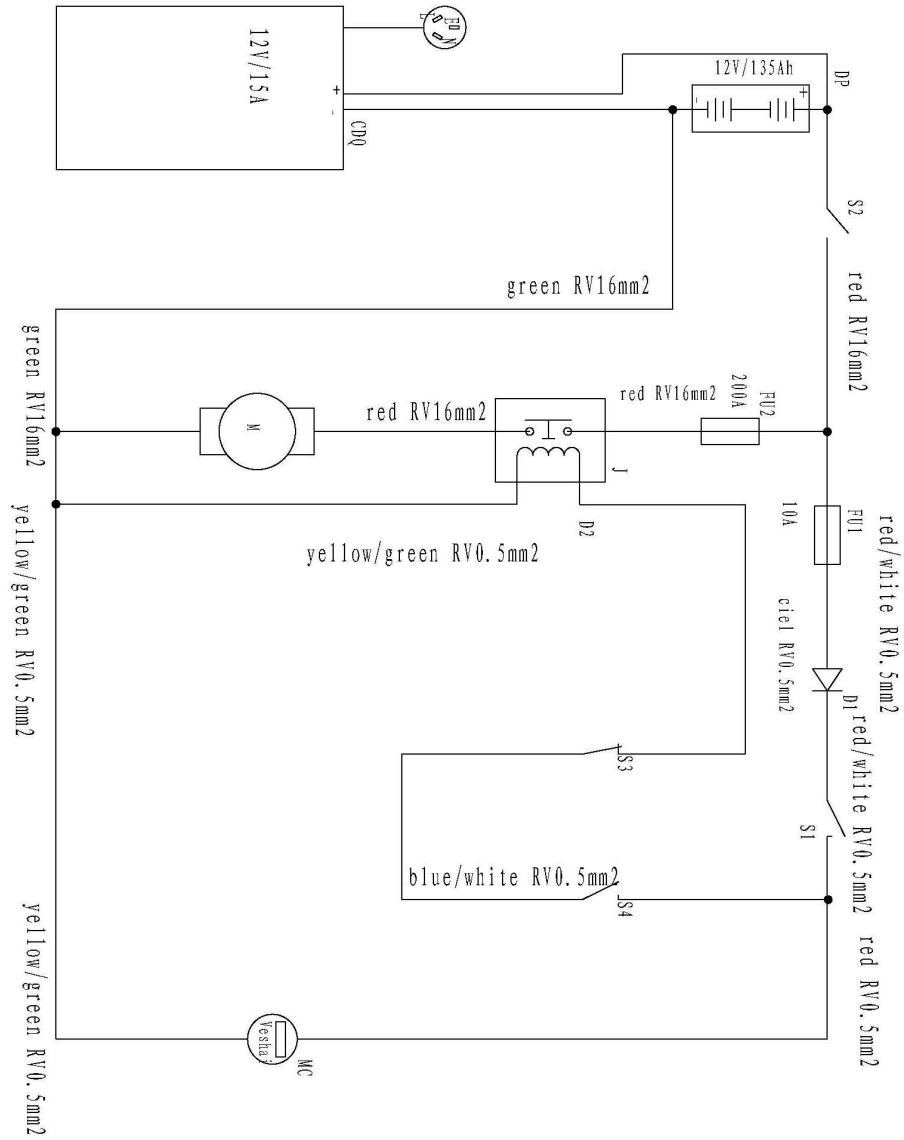

NO	Name	Code	Specification	Qty
1	Power meter	MC	DC12V	1PC
2	Lift motor	M	DC12v/1.5KW	1PC
3	Battery	DP	12V/135Ah	1PC
4	Lift motor contactor	J	MZJ200S 12V	1PC
5	Control circuit fuse	FU1	FS-10 10A	1PC
6	Hydraulic circuit fuse	FU2	200A	1PC
7	Key switch	S1	JT-001	1PC
8	Emergency stop	S2	ZDK31-250	1PC
9	Lift limit switch	S3	TM1703	1PC
10	Lift micro switch	S4	YBLXW-5/11M	1PC
11	Diode	D1	IN5404	1PC
12	Diode	D2	IN4007	1PC
13	Battery charger	CDQ	12V/15A	1PC

Parts drawing

Assembly Explode Drawing

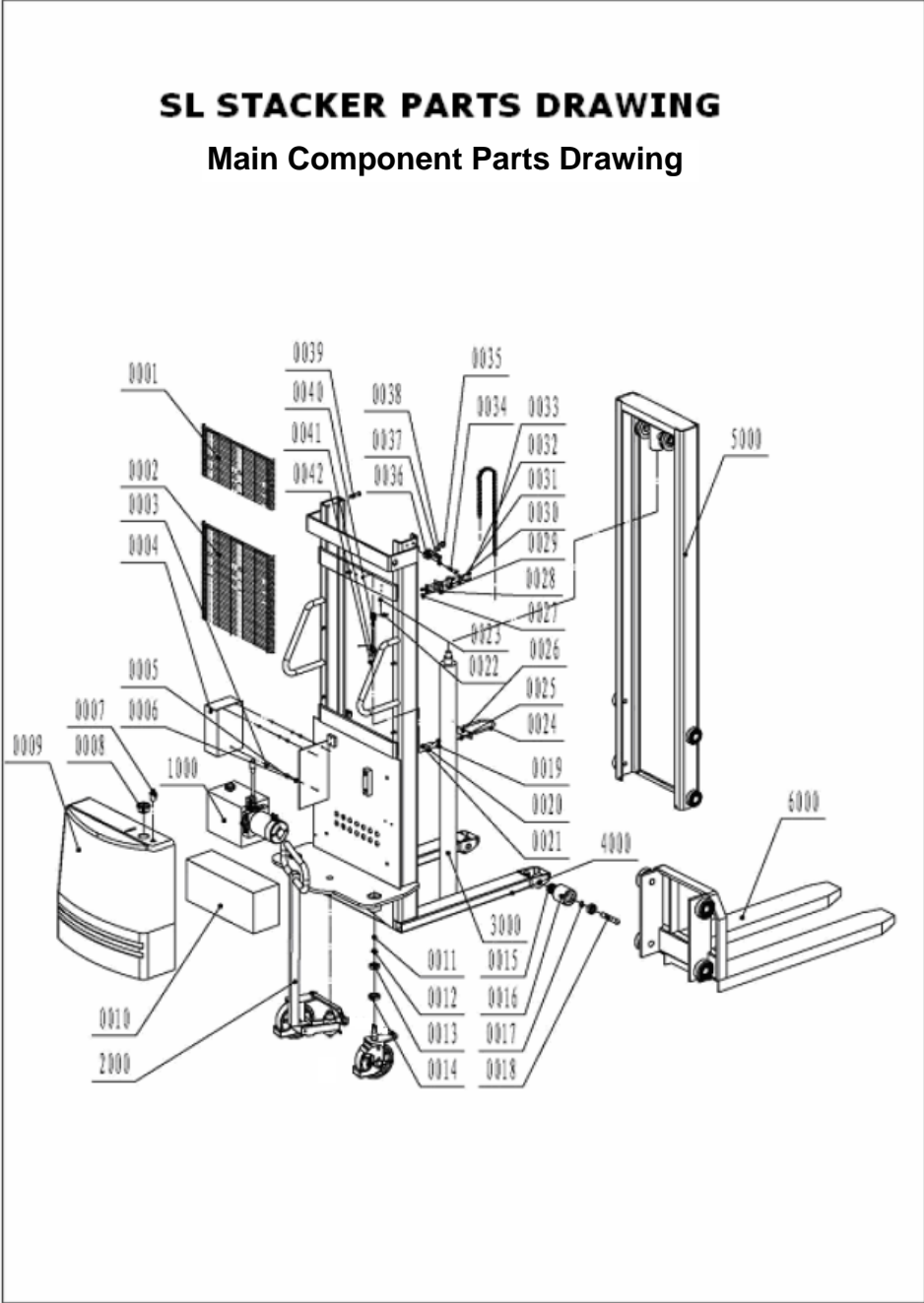

Main Component Assembly - Parts List

Part Number	Description	Qty.	Part Number	Description	Qty.
SL-0001	Mesh, Top	1	SL-0026	Washer, Flat	2
SL-0002	Mesh, Lower	1	SL-0027	Screw M6x12	2
SL-0003	Washer, Flat	3	SL-0028	Nut, Hex	1
SL-0004	Charger - Soneil	1	SL-0029	Patch	1
SL-0005	Washer, Lock (M6)	3	SL-0030	Switch, Limit	1
SL-0006	Screw, Pan Head	3	SL-0031	Washer, Flat	2
SL-0007	E-Stop, Mushroom	1	SL-0032	Screw	2
SL-0008	Gauge, Battery, Charge Indicator	1	SL-0033	Chain	2
SL-0009	Cover, Machine	1	SL-0034	Washer, Flat	2
SL-0010	Battery, 12V/110 - 140Ah	1	SL-0035	Bearing	1
SL-0011	Nut, Castle	2	SL-0036	Adjust Bolt	2
SL-0012	Washer, Spider	2	SL-0037	Nut, Hex	2
SL-0013	Bearing, Ball	2	SL-0038	Nylon wheel	2
SL-0014	Bearing, Ball	2	SL-0039	Screw, Hex Head	2
SL-0015	Bearing, Ball	4	SL-0040	Shaft	2
SL-FF-0016	Wheel, Front (78x85mm)	2	SL-0041	Washer, Flat	2
SL-AA-0016	Wheel, Front (100x74mm)	2	SL-0042	Nut, Hex	4
SL-0017	Washer, Lock	2	SL-1000	Power unit	1
SL-0018	Pin	2	SL-2000	Steering Assembly	1
SL-0019	Nut, Hex	3	SL-3000-63	Cylinder Assembly	1
SL-0020	Nut, Hex	2	SL-3000-118	Cylinder Assembly	1
SL-0021	Bolt, Hex Head	1	SL-3000-137	Cylinder Assembly	1
SL-0022	Pin	2	SL-4000	Main Frame	1
SL-0023	Cotter Pin	4	SL-5000	Inner Mast Assembly	1
SL-0024	Cylinder, U Bracket	1	SL-6000-AA	Fork Assembly	1
SL-0025	Press Block	1	SL-6000-FF	Fork Assembly	1

Parts drawing & Parts list

Inner mast drawing

SL INNER MAST

Part Number	Description	Qty.	Part Number	Description	Qty.
SL-5101	Washer, Flat	4	SL-5202	Bolt, Hex Head	2
SL-5102	Washer, Lock	4	SL-5203	Wheel	4
SL-5103	Bolt, Socket head	4	SL-5204	Ball Bearing 6305	4
SL-5104	Chain Wheel protector	1	SL-5205	Snap Ring 35mm	4
SL-5105	Chain wheel	2	SL-5100	Chain Wheel Assembly	1
SL-5106	Snap ring 30mm	2	SL-5200	Inner Mast Assembly	1
SL-5201	Underside Bracket	1			

Parts drawing & Parts list

Fork drawing

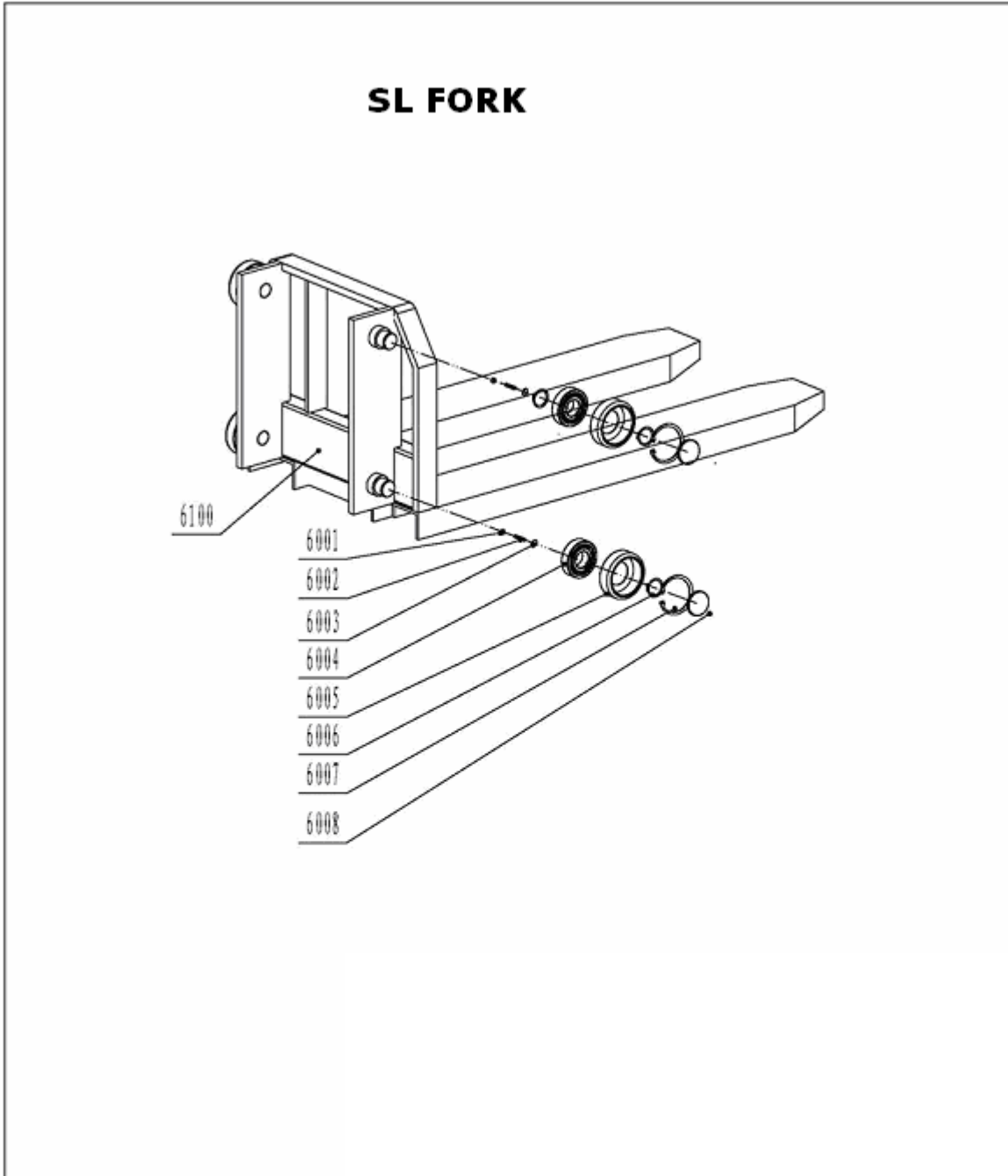

Part Number	Description	Qty.	Part Number	Description	Qty.
SL-FF-6001	Nut, Hex	4	SL-AA-6001	Nut, Hex	4
SL-FF-6002	Screw, Socket Head	4	SL-AA-6002	Screw, Socket	4
SL-FF-6003	Middle Tag	4	SL-AA-6003	Middle Tag	4
SL-FF-6004	Ball Bearing 6305	4	SL-AA-6004	Ball Bearing 6305	4
SL-FF-6005	Carriage Roller	4	SL-AA-6005	Carriage Roller	4
SL-FF-6006	Snap ring 35mm	4	SL-AA-6006	Snap ring 35mm	4
SL-FF-6007	Spring washer 80	4	SL-AA-6007	Spring washer 80	4
SL-FF-6008	Block	4	SL-AA-6008	Block	4
SL-FF-6100	FF Fork Assembly	1	SL-AA-6100	AA Fork Assembly	1

Parts drawing

Steering assembly drawing

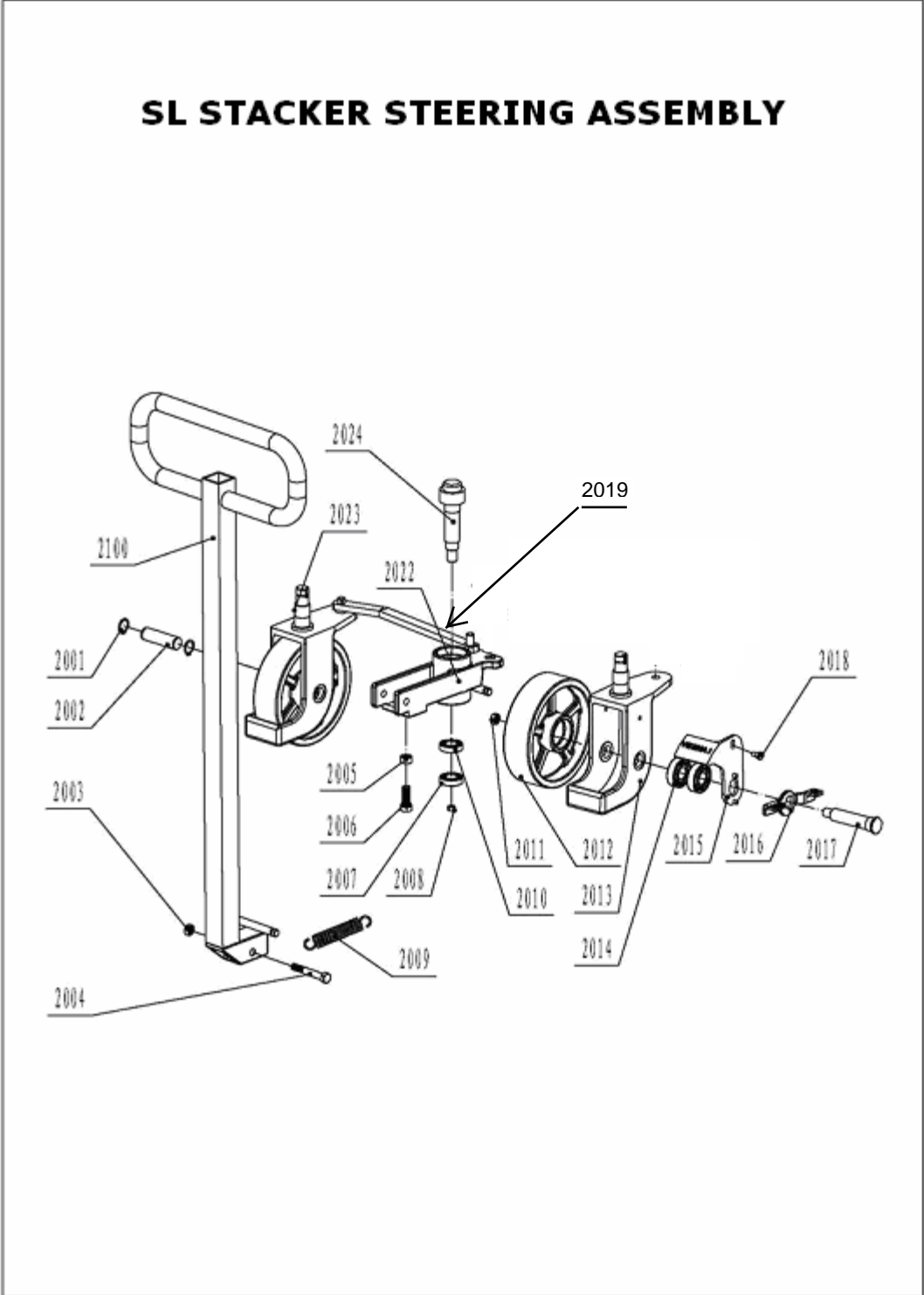

Steering Assembly - Parts List

Part Number	Description	Qty.
SL-2100	Handle	1
SL-2001	Ring, Retaining	2
SL-2002	Pin 20 x 112mm	1
SL-2003	Nut, Hex	1
SL-2004	Bolt, Socket Head	1
SL-2005	Nut, Hex	1
SL-2006	Hex Bolt M12 x 30	1
SL-2007	Bearing, Ball	1
SL-2008	Nut, Hex	1
SL-2009	Spring	2
SL-2010	Bearing, Ball	2
SL-2011	Nut, Hex	1
SL-2012	Steering Wheel	2
SL-2013	Swivel Wheel Frame	1
SL-2014	Bearing, Ball	4
SL-2015	Skid Plate (Brake Shoe)	1
SL-2016	Pedal	1
SL-2017	Pin	1
SL-2018	Screw	1
SL-2019	Link bar	1
SL-2020	Cotter Pin	4
SL-2021	Pin	4
SL-2022	Turning Assembly	1
SL-2023	Steering Wheel Assembly	1