



EX-CELL KAISER
 11240 MELROSE AVENUE
 FRANKLIN PARK, IL 60131
 PHONE: (847) 451-0451
 FAX: (847) 261-9448
 www.ex-cell.com

SELECT DESIRED POWDERCOAT FINISH:

- BRONZE
- MALACHITE
- CUSTOM (ANY RAL COLOR MATCH)



PERSPECTIVE

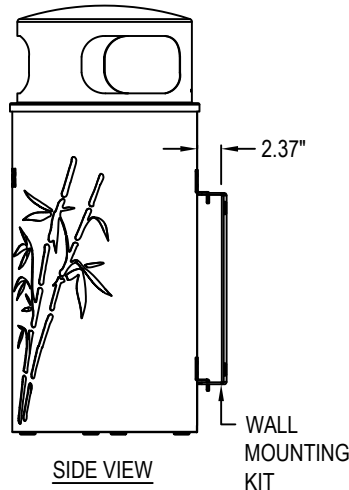

SIDE VIEW

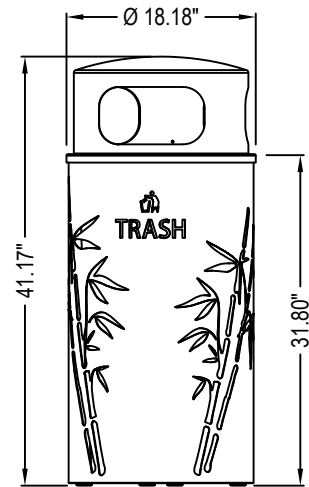

FRONT VIEW

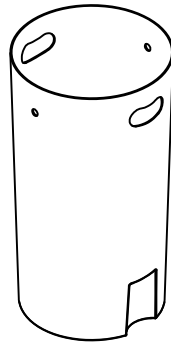

33 GALLON LINER

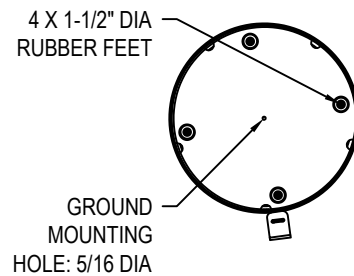

BOTTOM VIEW

MANUFACTURER NOTES:

1. BODY: 16 GA CRS; BOTTOM: 16 GA CRS. COMPLETELY WELDED CONSTRUCTION.
2. LID: ALUMINUM, PREPARED IN 5 STAGE PRETREATMENT AND ELECTROSTATICALLY POWDER COATED WITH TGIC POLYESTER POWDER COATING 2-3 MIL THICKNESS. OPENINGS: 5.50" X 10" OR 5" DIAMETER.
3. RIGID LEAKPROOF LINER, 33 GALLON CAPACITY. COLOR COORDINATED, LLDPE WITH BAG RETENTION HOLES AND CUT OUT LIFT HANDLE.
4. UNIT SITS ON 4 RUBBER FEET WHICH ARE SCREWED TO BOTTOM OF UNIT.
5. LID IS ATTACHED TO UNIT WITH A PVC COATED LANYARD CABLE.
6. GROUND MOUNTING KIT IS INCLUDED (CONCRETE ANCHOR, 5/16-18 HEX HEAD BOLT AND 3/8 FLAT WASHER).
7. WALL MOUNTING KIT IS INCLUDED (B-1022).

NOTES:

1. INSTALLATION TO BE COMPLETED IN ACCORDANCE WITH MANUFACTURER'S SPECIFICATIONS.
2. DO NOT SCALE DRAWING.
3. THIS DRAWING IS INTENDED FOR USE BY ARCHITECTS, ENGINEERS, CONTRACTORS, CONSULTANTS AND DESIGN PROFESSIONALS FOR PLANNING PURPOSES ONLY. THIS DRAWING MAY NOT BE USED FOR CONSTRUCTION.
4. ALL INFORMATION CONTAINED HEREIN WAS CURRENT AT THE TIME OF DEVELOPMENT BUT MUST BE REVIEWED AND APPROVED BY THE PRODUCT MANUFACTURER TO BE CONSIDERED ACCURATE.
5. CONTRACTOR'S NOTE: FOR PRODUCT AND COMPANY INFORMATION VISIT www.CADdetails.com/info AND ENTER REFERENCE NUMBER 5283-051

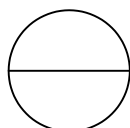

NATURE COLLECTION

33 GALLON BAMBOO TRASH RECEPTACLE (NS33 BB T)