

5579 Assembly Instructions

www.faedmunds.com

The 5579 can be set up to handle projects up to 50" wide following the instructions below. For project 25" wide and under you can eliminate steps 4, 6, 7 and 8 and the assembled frame will take up half of the floor space of the full sized frame.

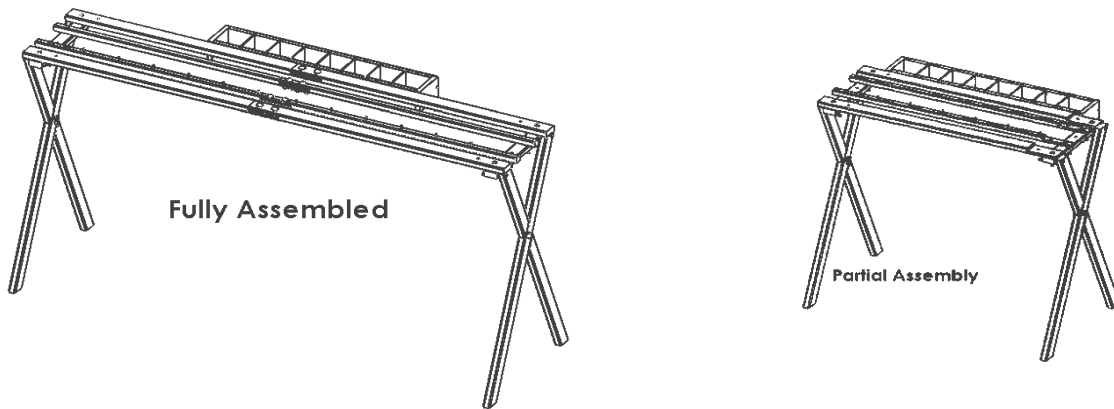

Leg Assembly

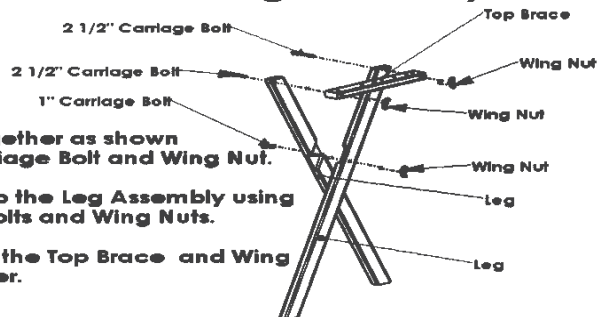

- 1) Assemble two Legs together as shown and secure with a 1" Carriage Bolt and Wing Nut.
- 2) Attach the Top Brace to the Leg Assembly using 2 of the 2 1/2" Carriage Bolts and Wing Nuts.
- 3) Repeat Steps #1 & 2 so the Top Brace and Wing Nuts are facing each other.

Outside Rear Crossbar Assembly

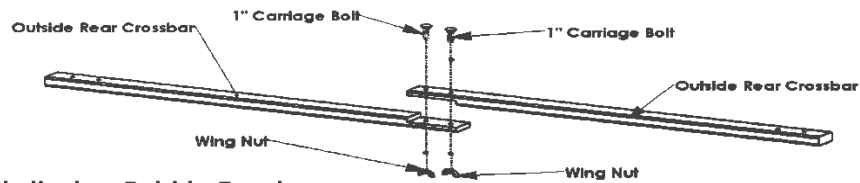

- 4) Assemble the two Outside Crossbars (the crossbars without the holes in the edge) using two of the 1" Carriage Bolts as shown.

Nail Bar Assembly

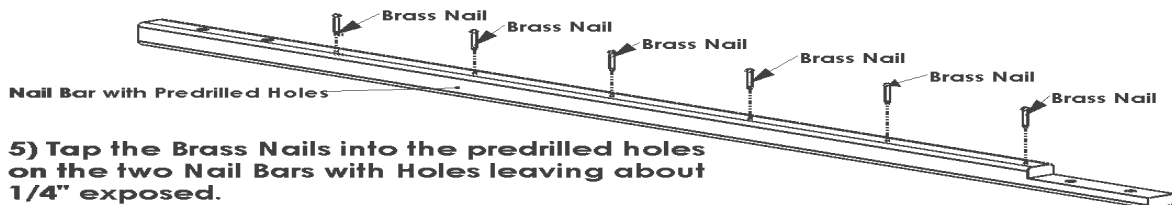

- 5) Tap the Brass Nails into the predrilled holes on the two Nail Bars with Holes leaving about 1/4" exposed.

Nail Bar Assembly

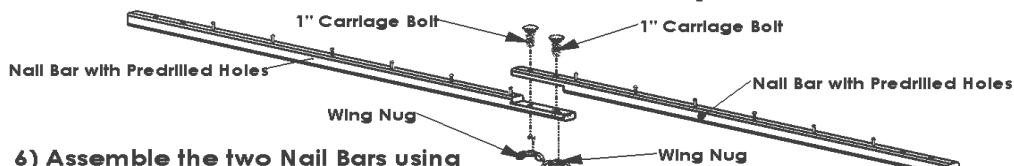

- 6) Assemble the two Nail Bars using two of the 1" Carriage Bolts and Wing Nuts as shown.

Inside Crossbar Assembly

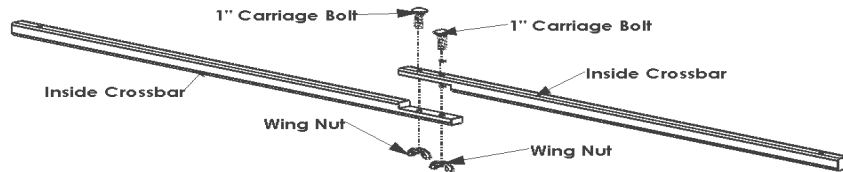

7) Assemble the Inside Crossbars using two of the 1" Carriage Bolts and Wing Nuts as shown.

Front Crossbar Assembly

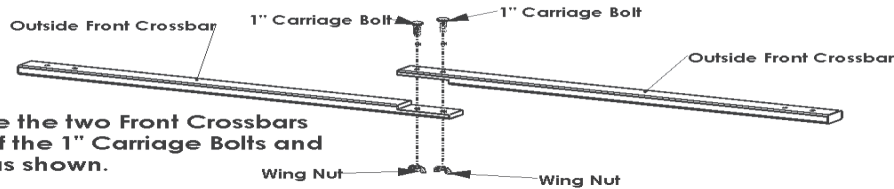

8) Assemble the two Front Crossbars using two of the 1" Carriage Bolts and Wing Nuts as shown.

Box Assembly

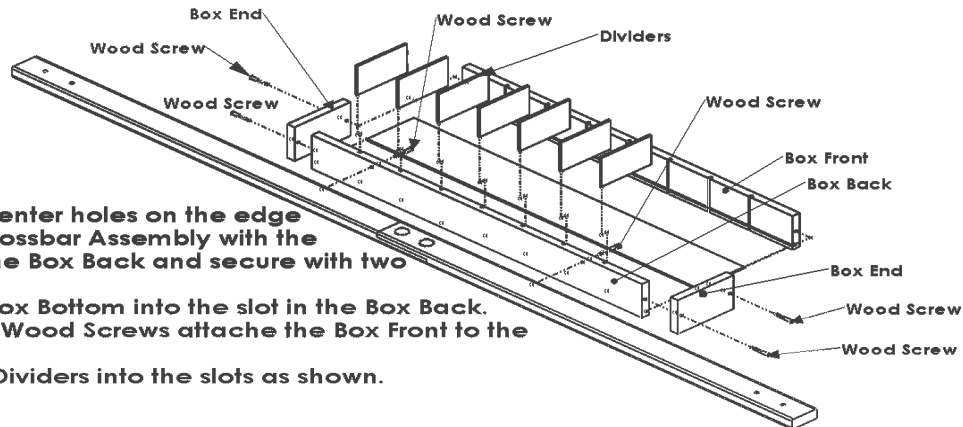

9) Align the center holes on the edge of the Front Crossbar Assembly with the two holes in the Box Back and secure with two wood screws.

10) Slide the Box Bottom into the slot in the Box Back.

11) Using two Wood Screws attach the Box Front to the Box Ends.

12) Insert the Dividers into the slots as shown.

5579 Final Assembly



13) Using 2" Carriage Bolts and Wing Nuts, attach the Rear Crossbar Assembly, Nail Bar Assembly, Inside Crossbar Assembly and the Front Crossbar Assembly to the Top Braces on the Leg Assemblies as shown.

Parts List:

4- Legs	1- Box Front	10- 1" Carriage Bolts
2- Top Braces	1- Box Back	8- 2" Carriage Bolts
2- Front Cross Bars (holes in one edge)	2- Box Ends	4- 2 1/2" Carriage Bolts
2- Rear Cross Bars	1- Box Bottom	22- Wing Nuts
2- Nail Bars	7- Dividers	12- Brass Nails
2- Inside Crossbars	6- Wood Screws	