

ASSEMBLY INSTRUCTIONS

ITEM CODE: WF290128/WF290129

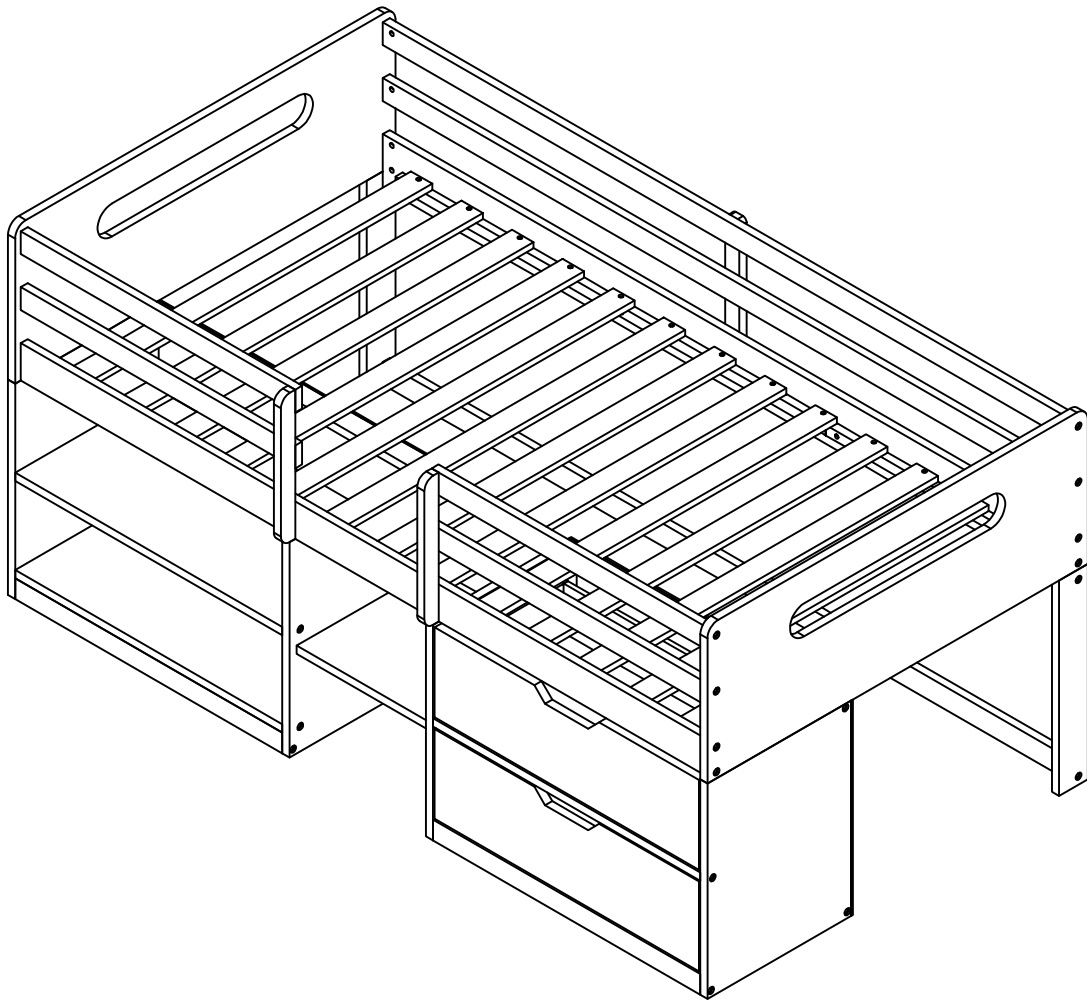

SAFFTY WARNINGS AND GENERAL NOTES

1. Follow the information on the warnings on the bunk bed end structure and on the carton. Do not remove the warning label from the bed
2. Always use the recommended size mattress on mattress support, or both, to help prevent the likelihood of entrapment on falls
3. Do not allow children under 6 years of age to the upper bunk
4. Periodically check and ensure the guardrail, ladder and other components are in their proper position free from damage, and all connectors are tight
5. Do not allow horseplay on or under beds.
6. Always prohibit jumping on the bed
7. Prohibit more than one person on upper bunk.
8. Always use ladder for entering and leaving the upper bunk.
9. Do not use substitute parts. Contact the manufacturer or dealer for replacement parts.
10. Use of a night-light may provide added safety precaution for a child using the upper bunk.
11. Always use guardrails on both long sides of the upper bunk.
12. If the bunk bed will be placed next to a wall, the guardrail that runs the full length of the bed should be placed against the wall to prevent entrapment between the bed and the wall.
13. The use of water or sleep flotation mattresses is prohibited
14. STRANGULATION HAZARD- Never attach or hang items to any part of the bunk bed that are not designed for use with the bed.
15. Keep these instructions for future reference.
16. We recommend assembling your bunk bed on the shipping carton to protect your floor or carpet
17. Be certain all staples are out of the box before beginning assembly on the shipping carton.
18. USE ONLY MATTRESSES WHICH ARE AS THE TABLE BELOW ON UPPER AND ON

Bed type	Length	Width	Thickness
Twin Standard	74" – 75"	38 ½"	6" max

19. SURFACE OF MATTRESS MUST BE AT LEAST 5" (127MM) BELOW THE UPPER EDGE OF GUARDRAILS.
20. Replacement Parts, including additional guardrails, may be obtained from any of our (GIGACLOUD TECHNOLOGY (USA) INC) dealers;

DETAIL VIEW

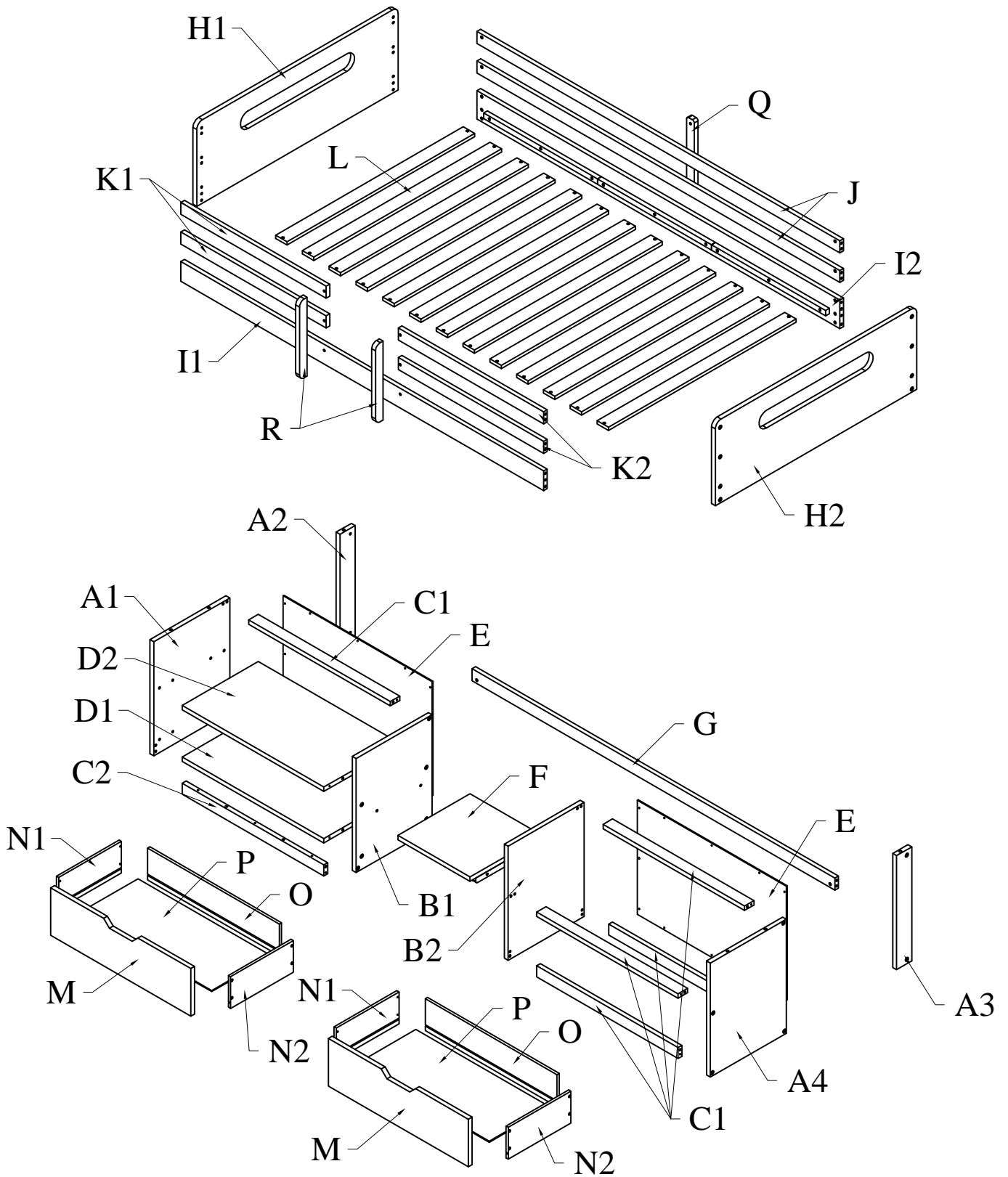

BOX 1: WF290128

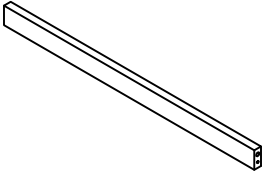
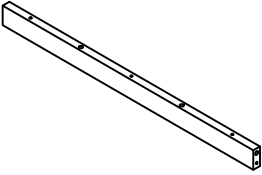
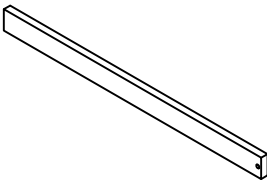
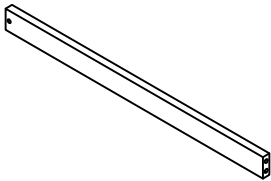
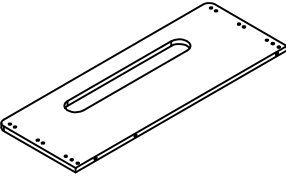
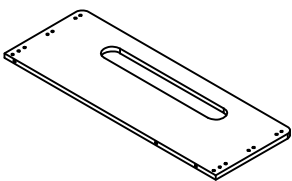
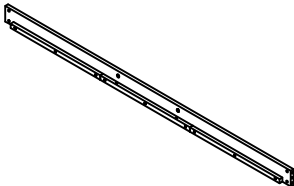
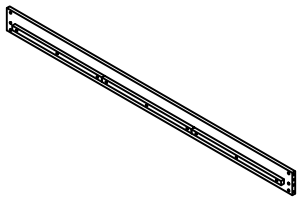
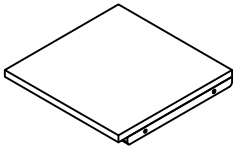
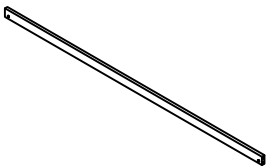
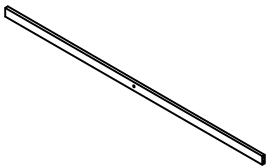
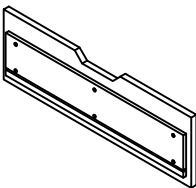
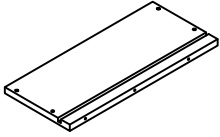
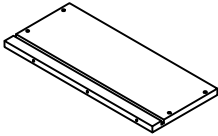
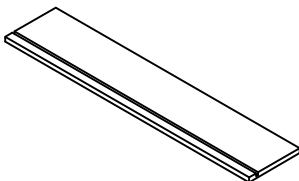
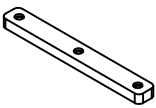
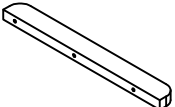
<p>C1</p>  <p>Support bar (5pcs)</p>	<p>C2</p>  <p>Support bar of bottom (1pc)</p>	<p>K1</p>  <p>Front rails - left (2pcs)</p>	<p>K2</p>  <p>Front rails - right (2pcs)</p>
<p>H1</p>  <p>Side panel - left (1pc)</p>	<p>H2</p>  <p>Side panel - right (1pc)</p>	<p>I1</p>  <p>Front side rail (1pc)</p>	<p>I2</p>  <p>Back side rail (1pc)</p>
<p>F</p>  <p>Middle shelf (1pc)</p>	<p>G</p>  <p>Lower back rail (1pc)</p>	<p>J</p>  <p>Guardrail - back (2pcs)</p>	<p>M</p>  <p>Front drawer (2pcs)</p>
<p>N1</p>  <p>Side drawer - left (2pcs)</p>	<p>N2</p>  <p>Side drawer - right (2pcs)</p>	<p>O</p>  <p>Back drawer (2pc)</p>	<p>Q</p>  <p>Back vertical (1pc)</p>
<p>R</p>  <p>Front vertical (2pcs)</p>			

BOX 2: WF290129

A1

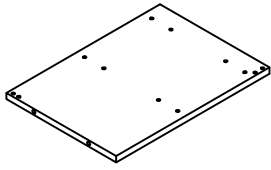

Front leg - left (1pc)

A2

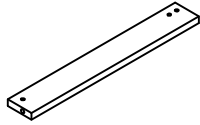

Back leg - left (1pc)

A3

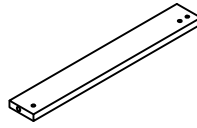

Back leg - right (1pc)

A4

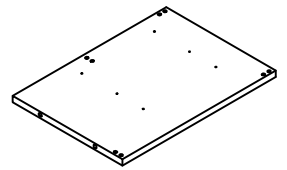

Front leg - right (1pc)

B1

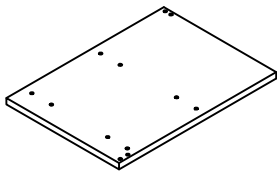

Partiton - left (1pc)

B2

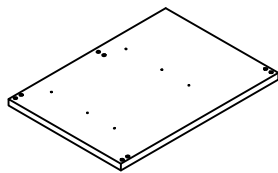

Partiton - right (1pc)

D1

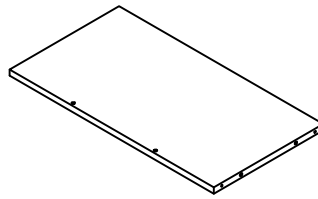

Bottom shelf (1pc)

D2

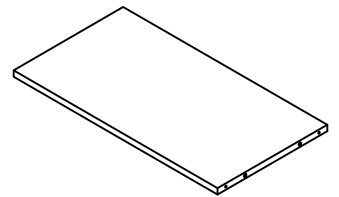

Middle shelf (1pc)

E

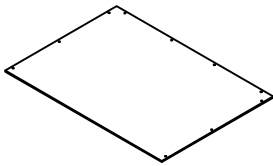

Back panel (2pcs)

L

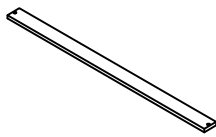





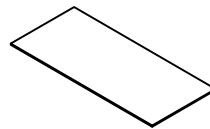

Slats (13pcs)

P

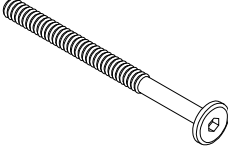
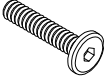

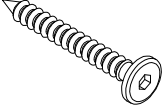
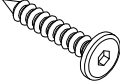
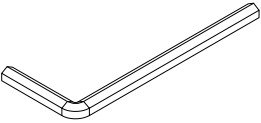
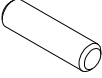
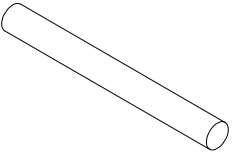
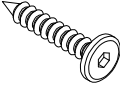
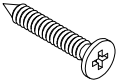
Bottom drawer (2pcs)

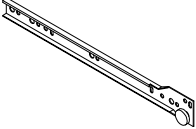
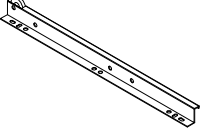
HARDWARE LIST: WF290129

<p>1</p>  <p>Hex - Head bolts Ø1/4" * 60- 20pcs</p>	<p>2</p>  <p>Hex - Head bolts Ø1/4" * 30- 4pcs</p>	<p>3</p>  <p>Horizontal - Hold bolts Ø1/4" - 20pcs</p>	<p>4</p>  <p>Hexagonal bolts catch wood Ø6 * 50 - 20pcs</p>
<p>5</p>  <p>Hexagonal bolts catch wood Ø6 * 40 - 6pcs</p>	<p>6</p>  <p>Allen key K4 - 1pc</p>	<p>7</p>  <p>Wood dowel Ø8 * 30 - 36pcs</p>	<p>8</p>  <p>Steel dowel Ø10 * 90 - 6pcs</p>
<p>9</p>  <p>Hexagonal bolts catch wood Ø6 * 30 - 3pcs</p>	<p>10</p>  <p>Wood crews M4 * 25 - 47pcs</p>	<p>12</p>  <p>Wood crews M4 * 15 - 20pcs</p>	<p>13L/R</p>  <p>L/R Sliding rail - outside 4pcs</p>
<p>14L/R</p>  <p>L/R Sliding rail - inside 4pcs</p>	<p>15</p>  <p>Wood crews M3.5 * 15 - 24pcs</p>		

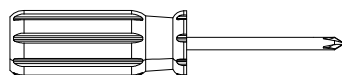

Assembly Tools Required (Not Included)

STEP 1

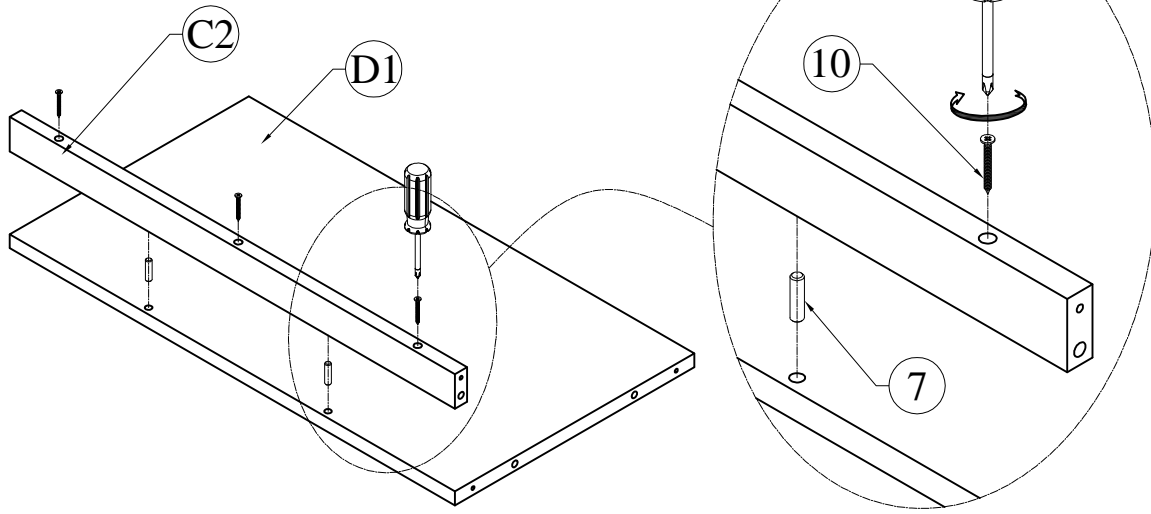

10

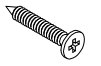

Wood screws
M4 * 25 - 3pcs

7



Wood dowel
Ø8 * 30 - 2pcs

STEP 2

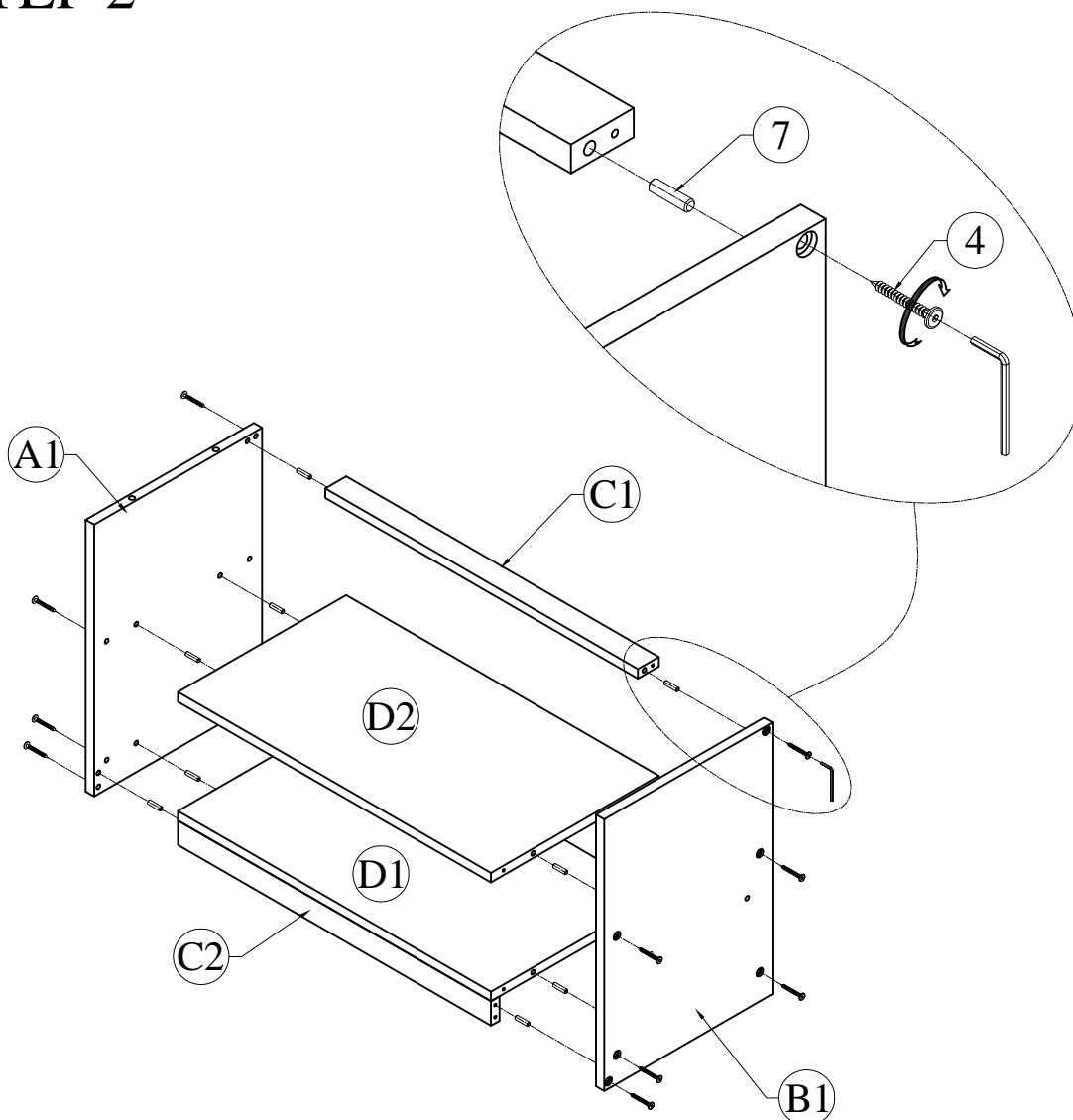

4



Hexagonal bolts catch wood
Ø6 * 50 - 12pcs

7



Wood dowel
Ø8 * 30 - 12pcs

STEP 3

12



Wood crews
M4 * 15 - 10pcs

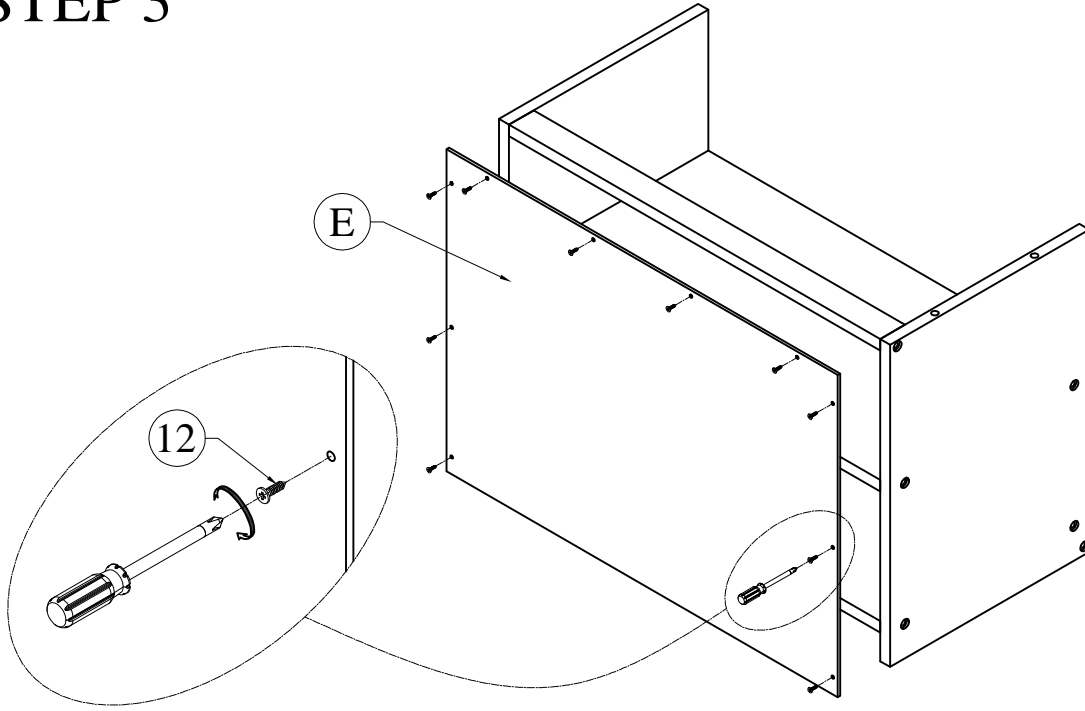

STEP 4

15



Wood crews
M3.5 * 15 - 12pcs

13L/R

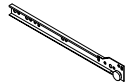

L/R Sliding rail - outside
4pcs

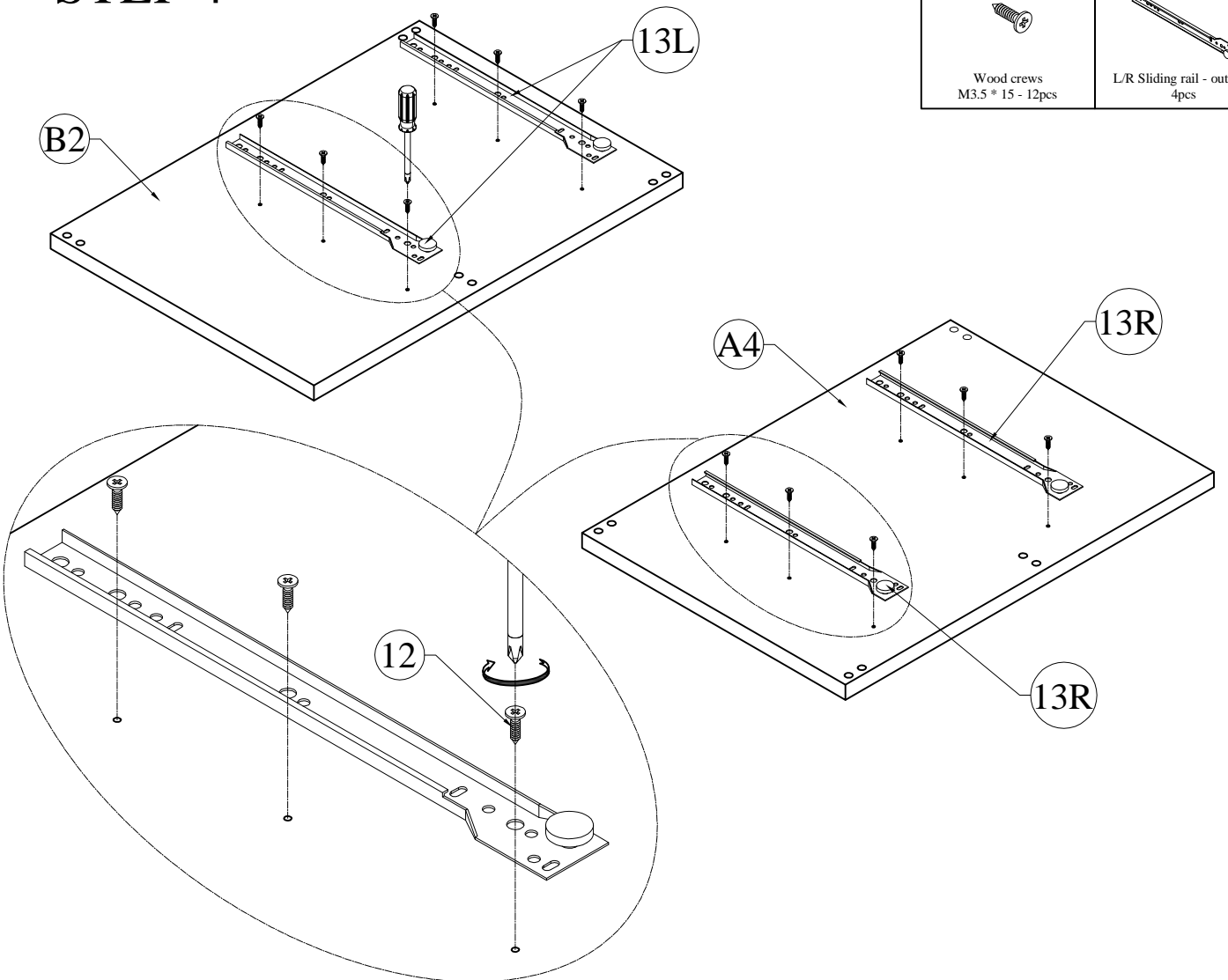

STEP 5

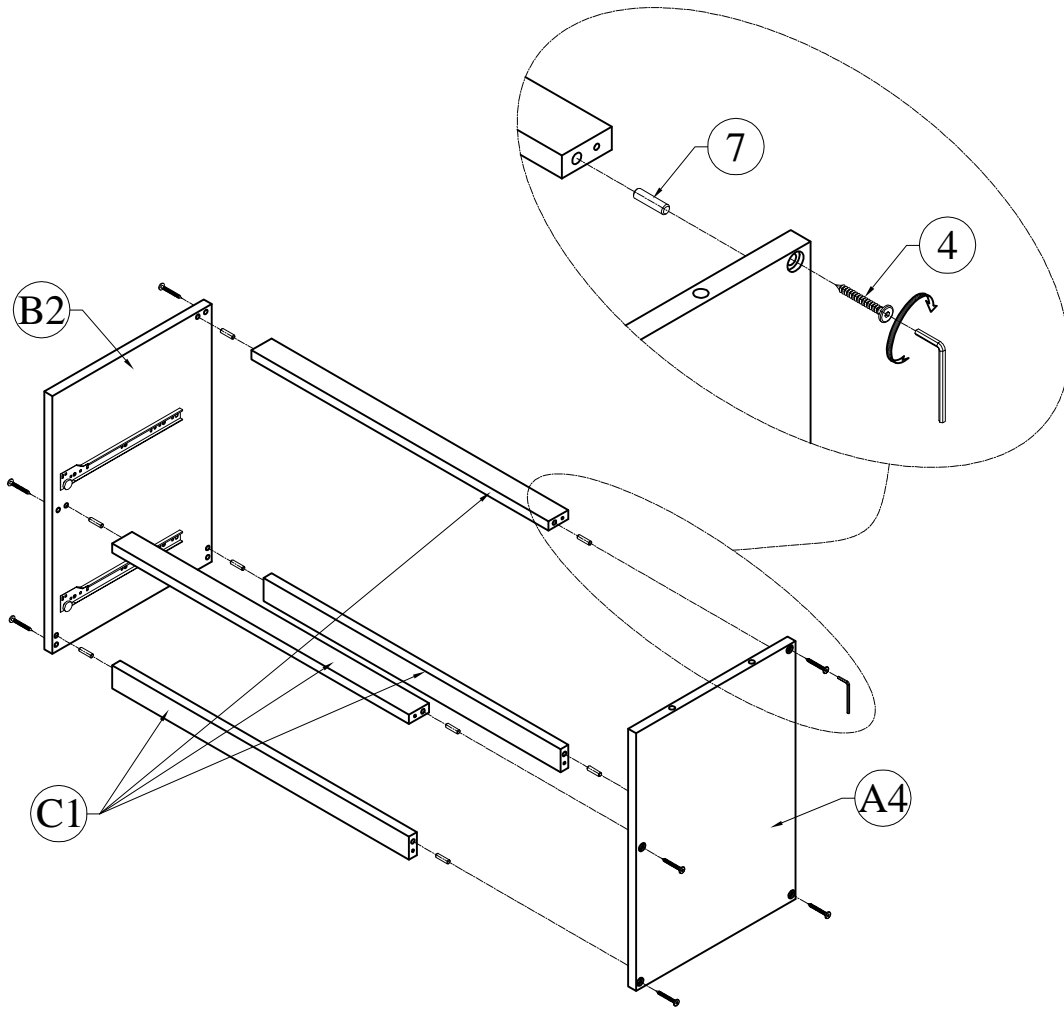

4



Hexagonal bolts catch wood
Ø6 * 50 - 12pcs

7



Wood dowel
Ø8 * 30 - 8pcs

STEP 6

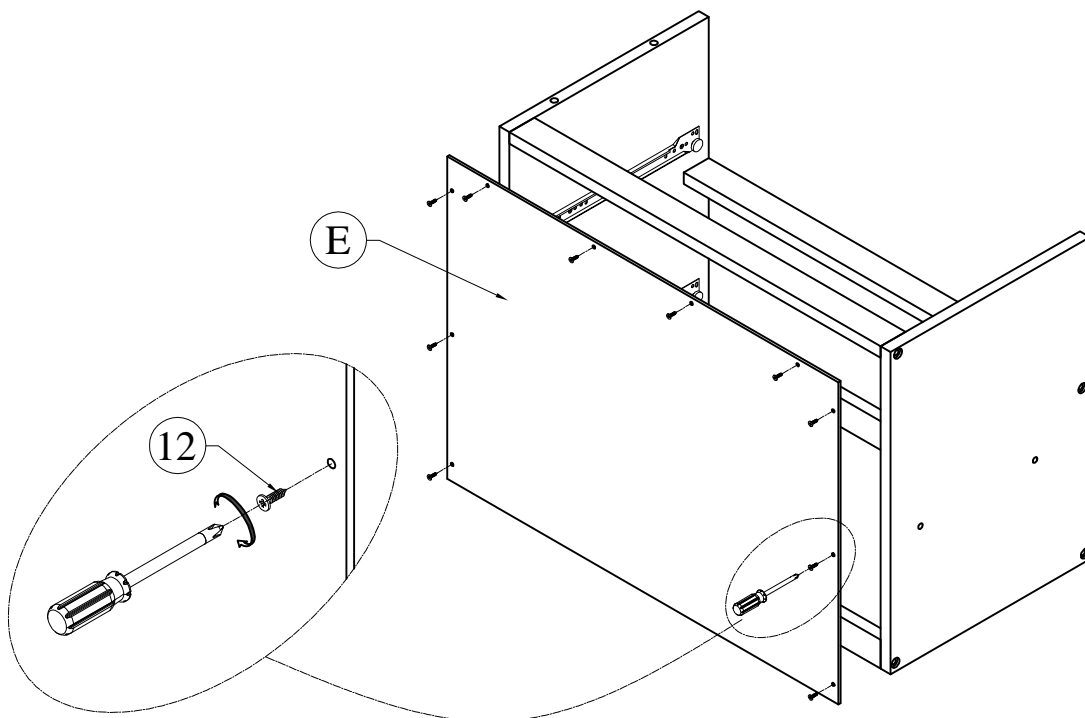

12



Wood crews
M4 * 15 - 10pcs

STEP 7

2



Hex - Head bolts
Ø1/4" * 30- 4pcs

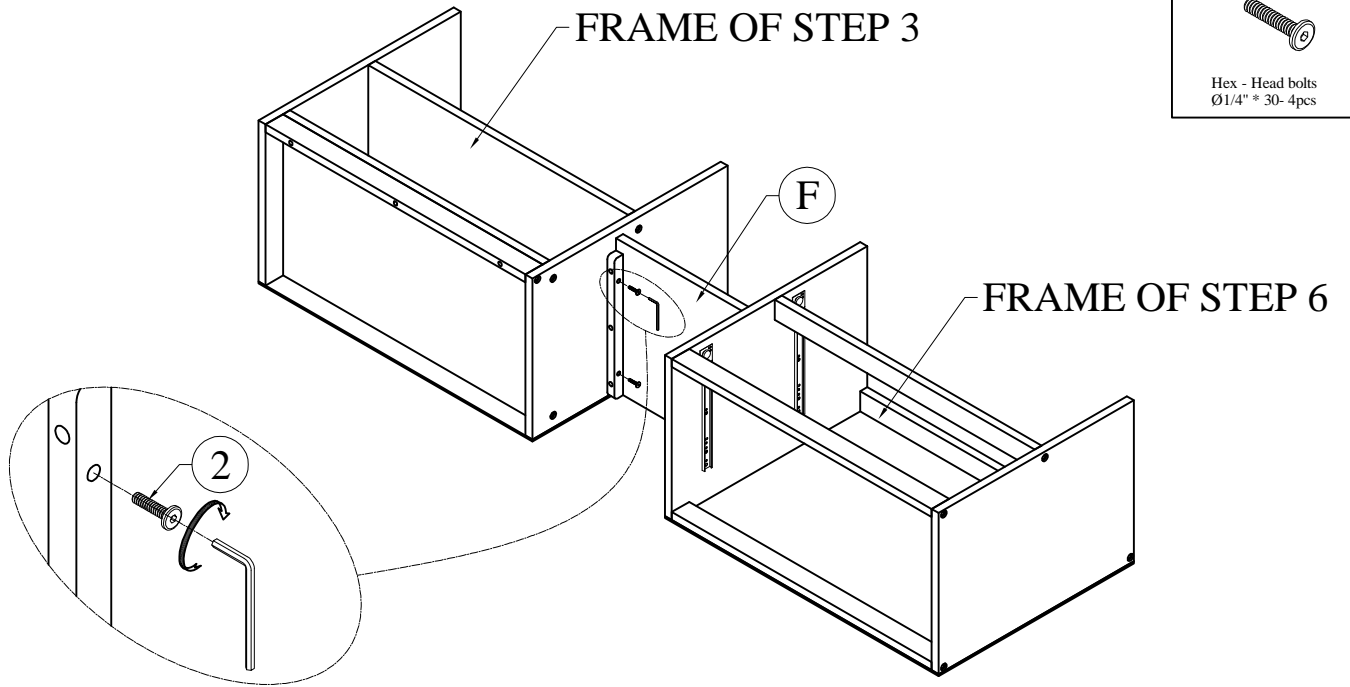

STEP 8

1

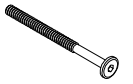

Hex - Head bolts
Ø1/4" * 60- 12pcs

3



Horizontal - Hold bolts
Ø1/4" - 12pcs

7



Wood dowel
Ø8 * 30 - 8pcs

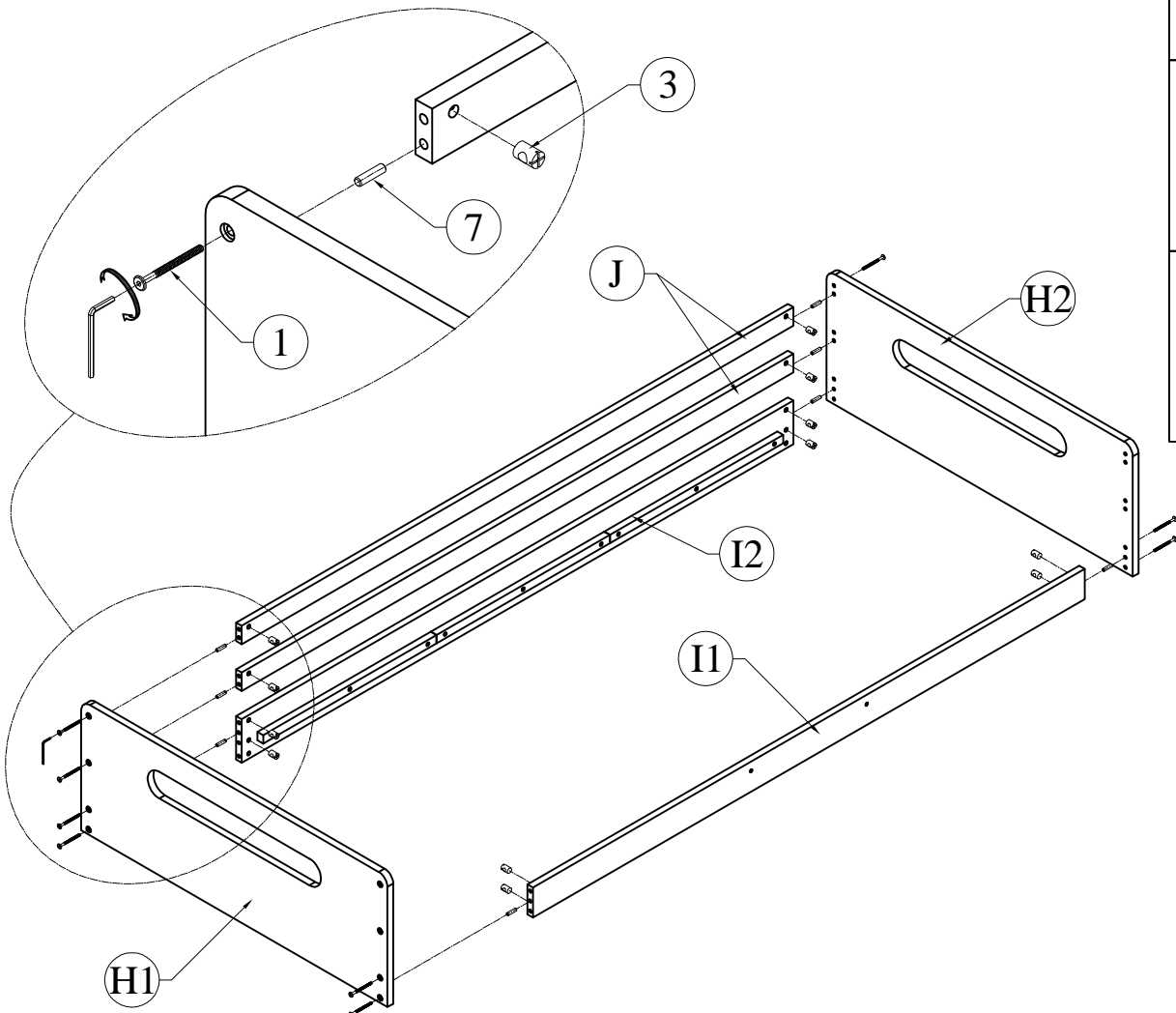

STEP 9

9



Hexagonal bolts catch wood
Ø6 * 30 - 3pcs

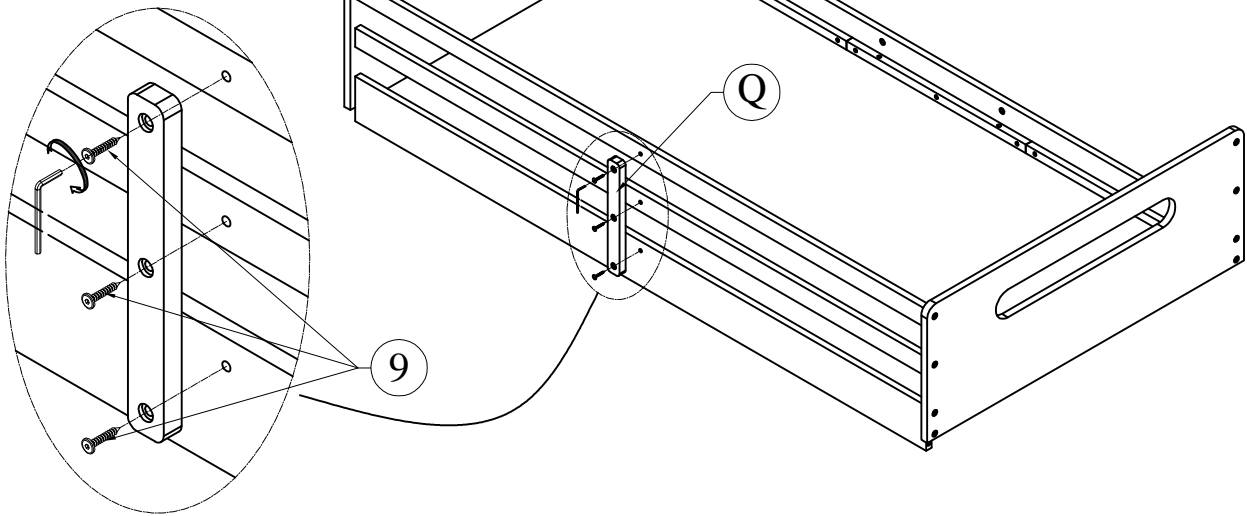

STEP 10

1

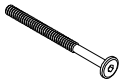

Hex - Head bolts
Ø1/4" * 60- 4pcs

3



Horizontal - Hold bolts
Ø1/4" - 4pcs

7



Wood dowel
Ø8 * 30 - 4pcs

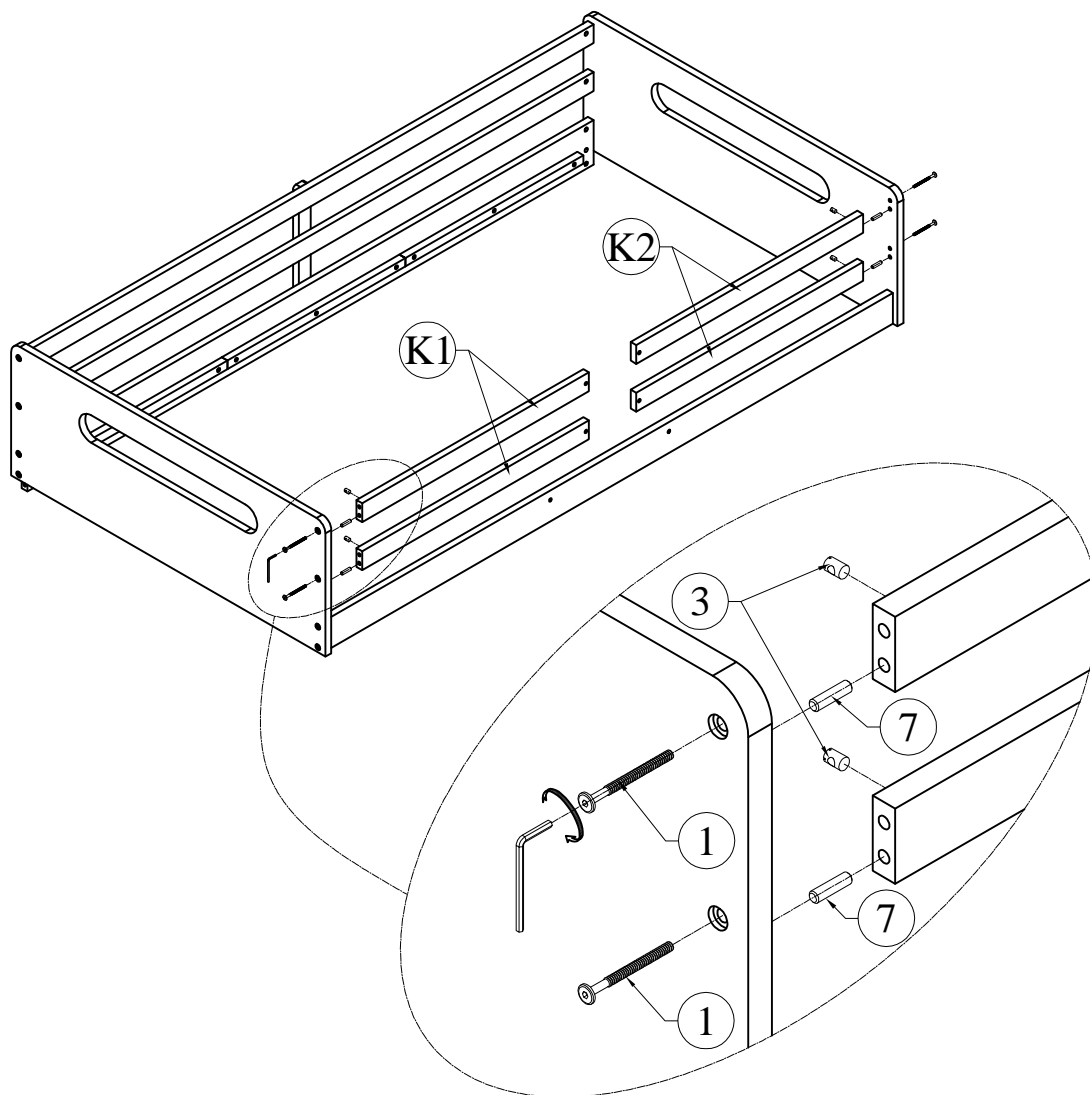

STEP 11

5



Hexagonal bolts catch wood
Ø6 * 40 - 6pcs

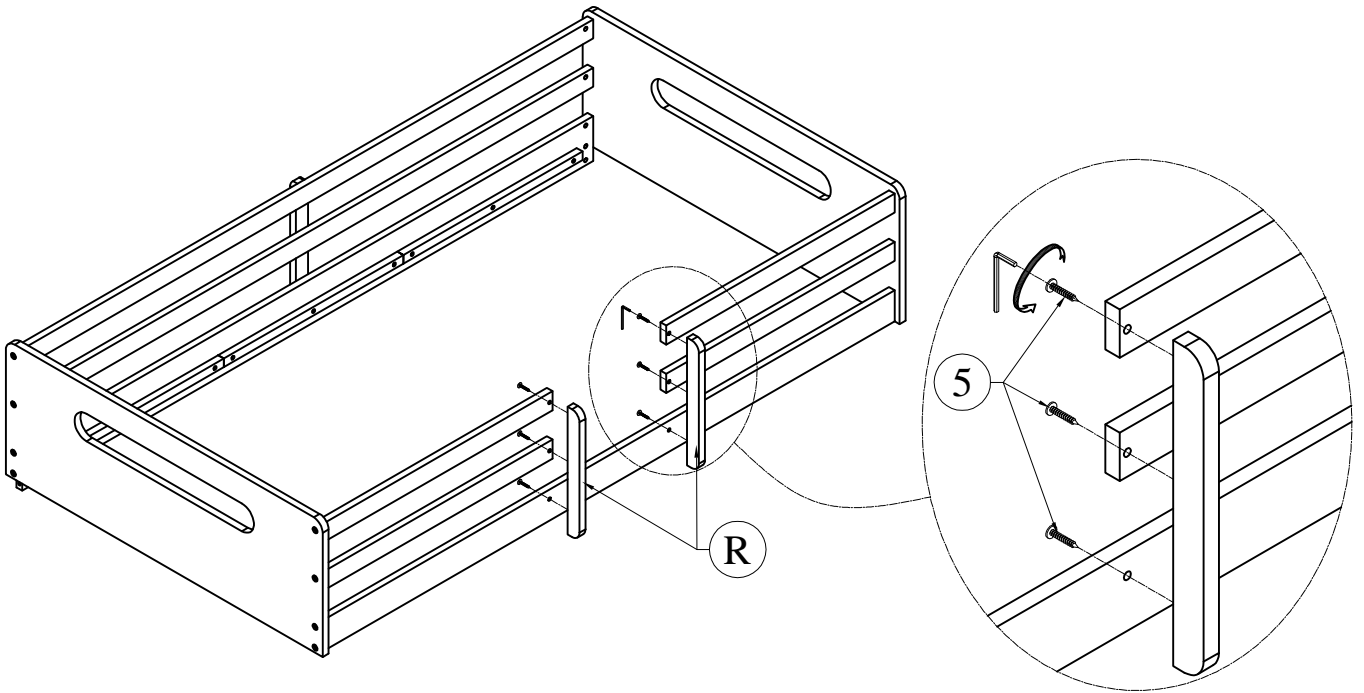

STEP 12

1

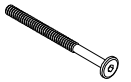

Hex - Head bolts
Ø1/4" * 60- 2pcs

3



Horizontal - Hold bolts
Ø1/4" - 2pcs

7



Wood dowel
Ø8 * 30 - 2pcs

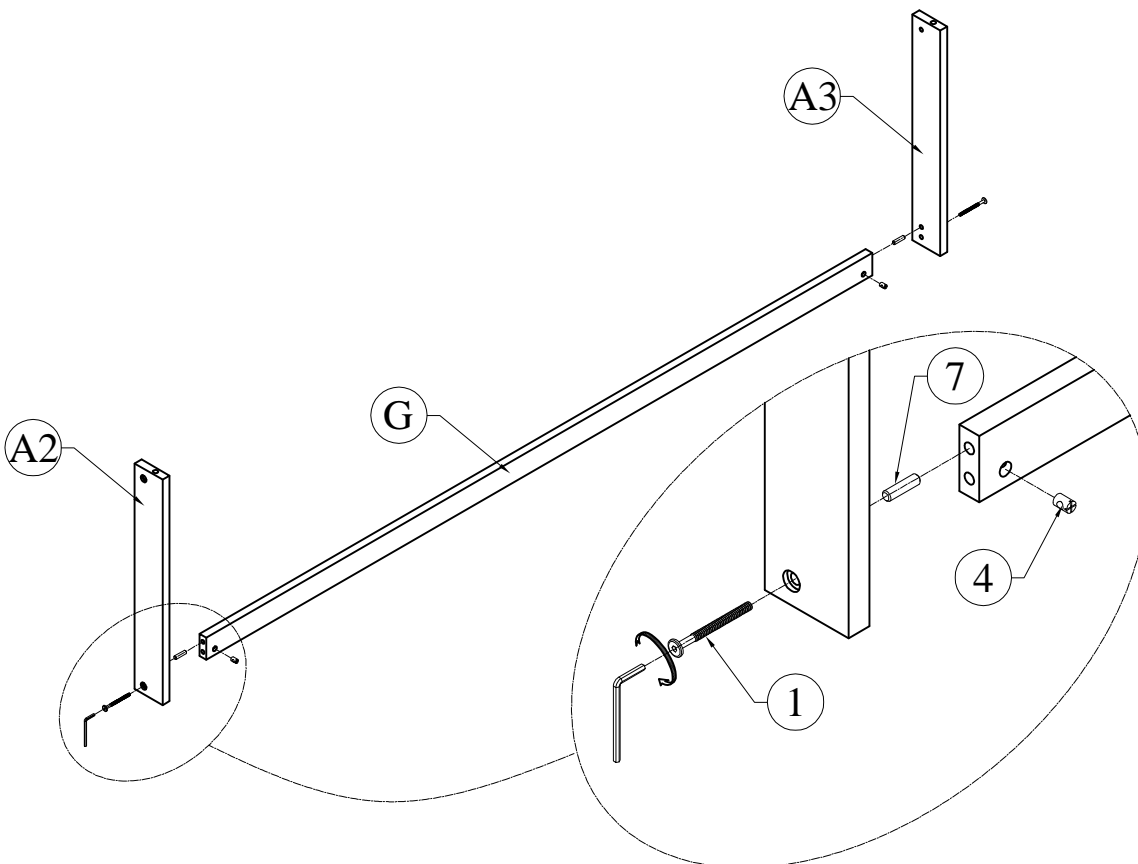

STEP 13

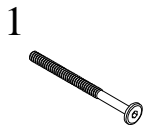
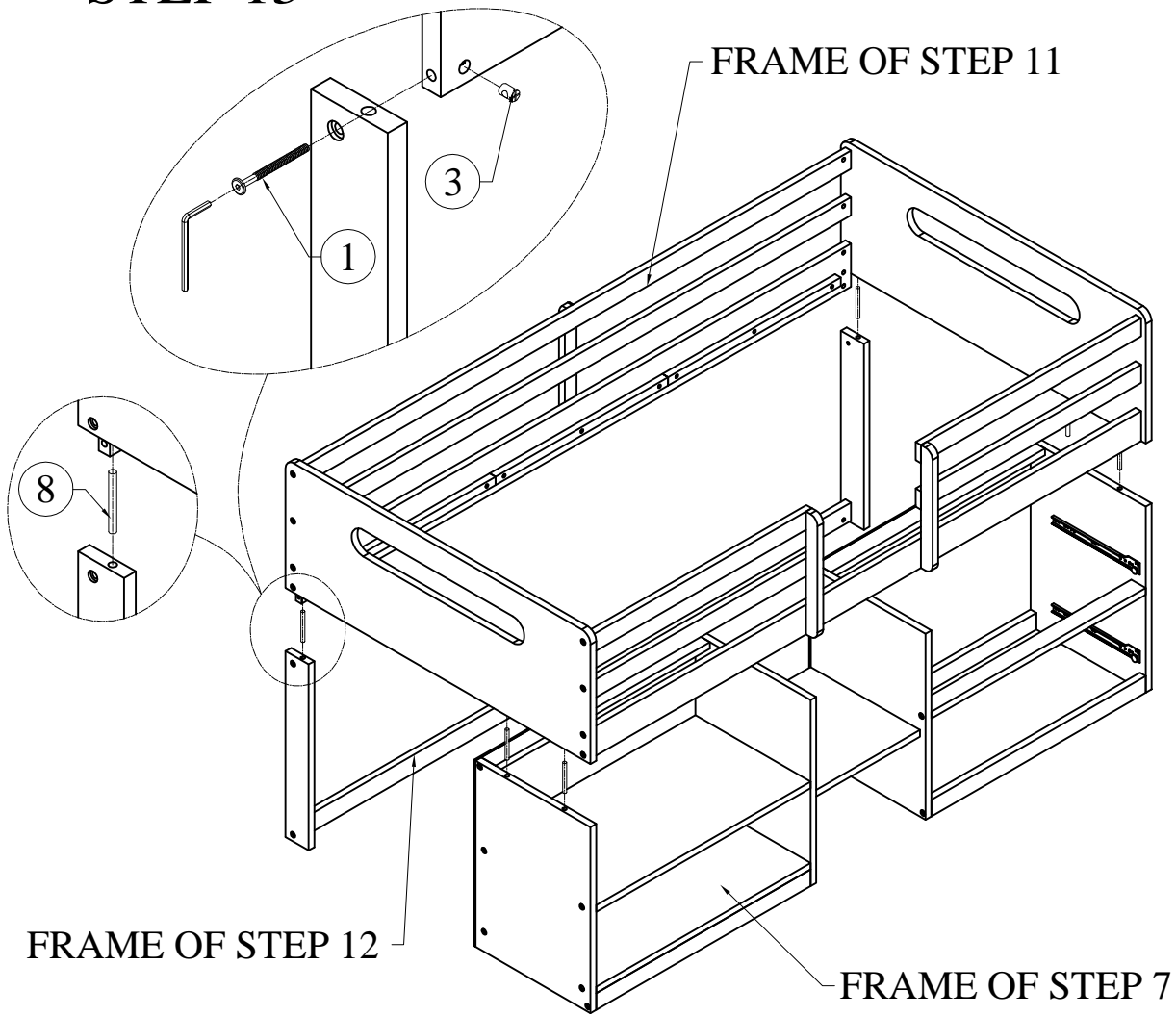

Hex - Head bolts
Ø1/4" * 60 - 2pcs

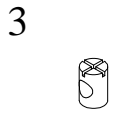

Horizontal - Hold bolts
Ø1/4" - 2pcs

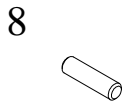

Steel dowel
Ø10 * 90 - 6pcs

STEP 14

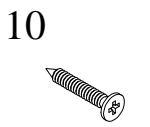
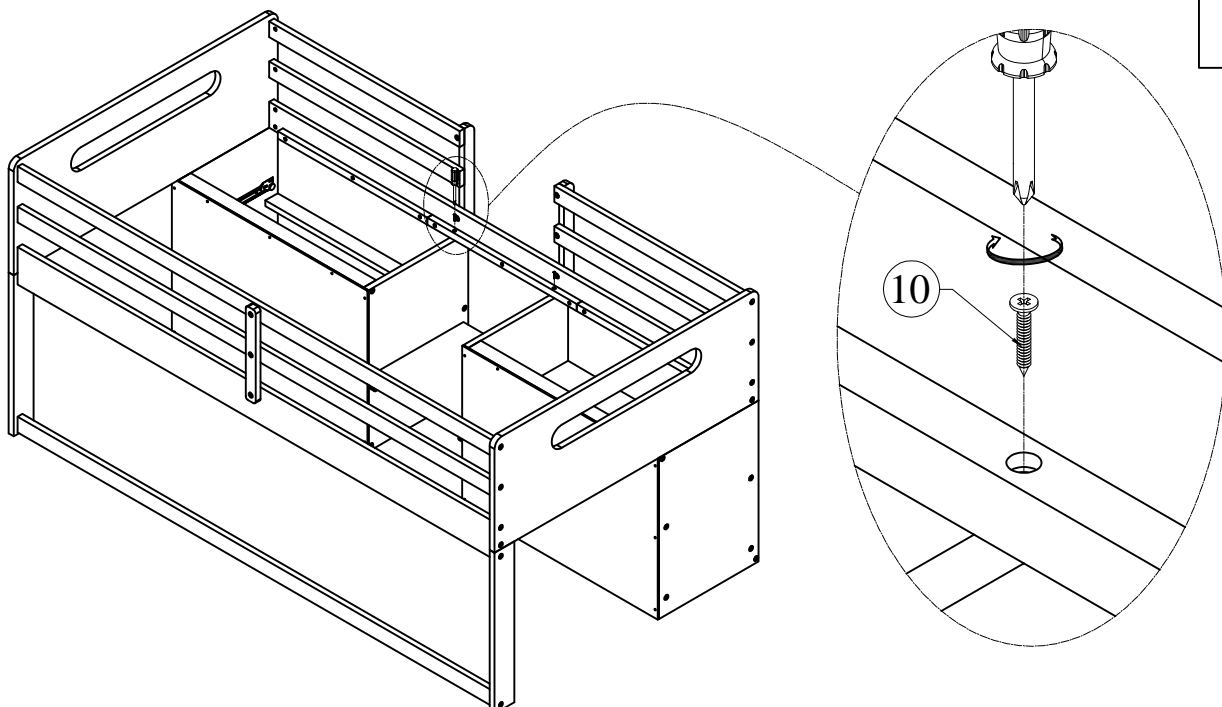

Wood crews
M4 * 25 - 2pcs

STEP 15

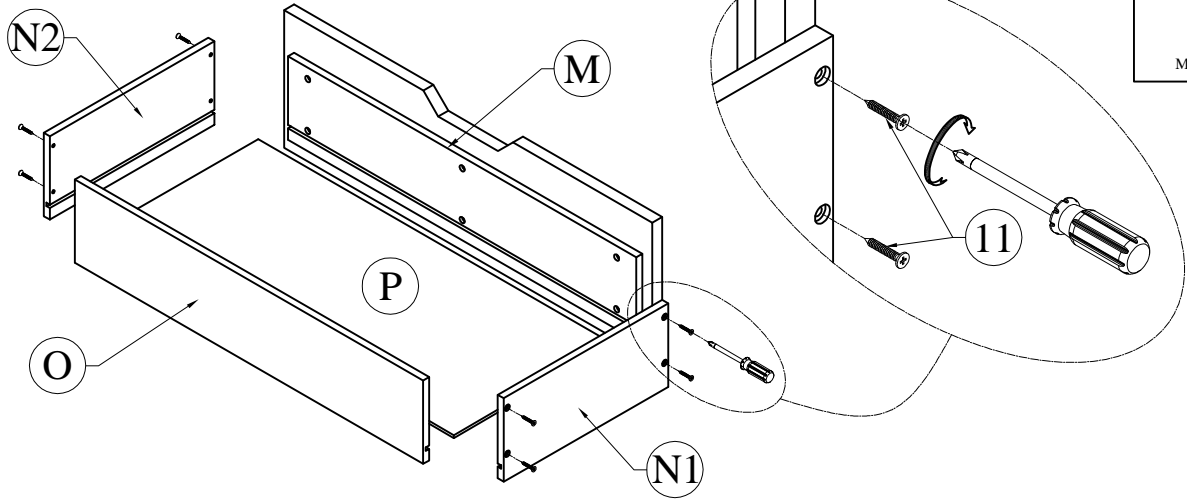

10



Wood crews
M4 * 25 - 16pcs

STEP 16

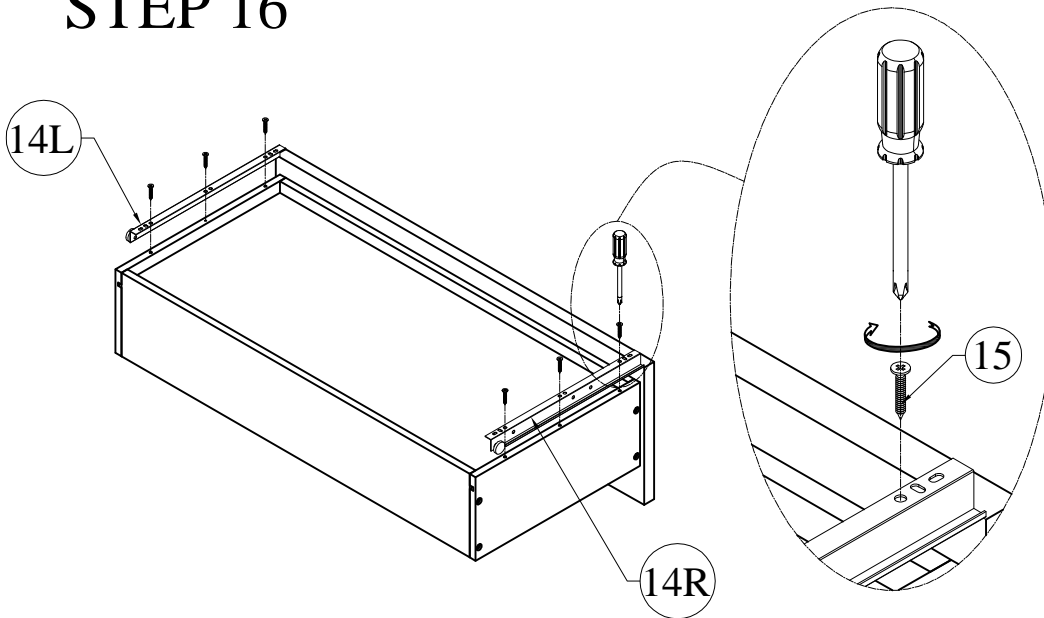

14L/R



15



Wood crews
M3.5 * 15 - 12pcs

STEP 17

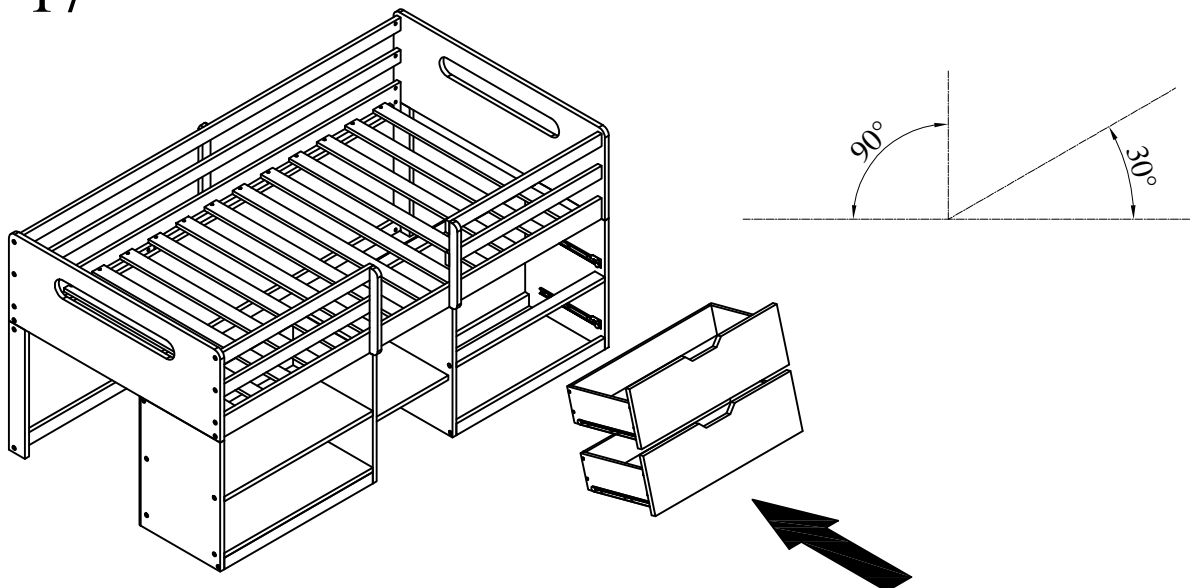

STEP 18

10



Wood screws
M4 * 25 - 26pcs

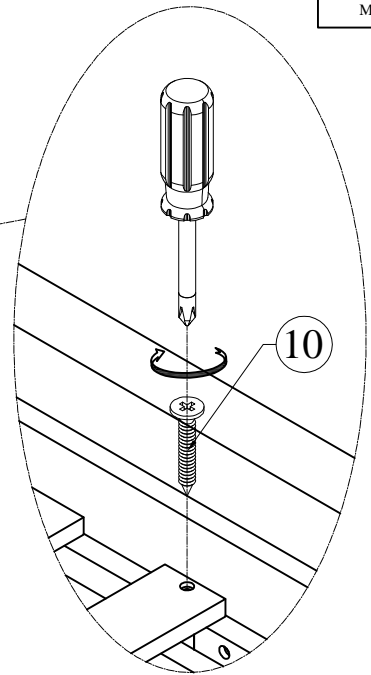
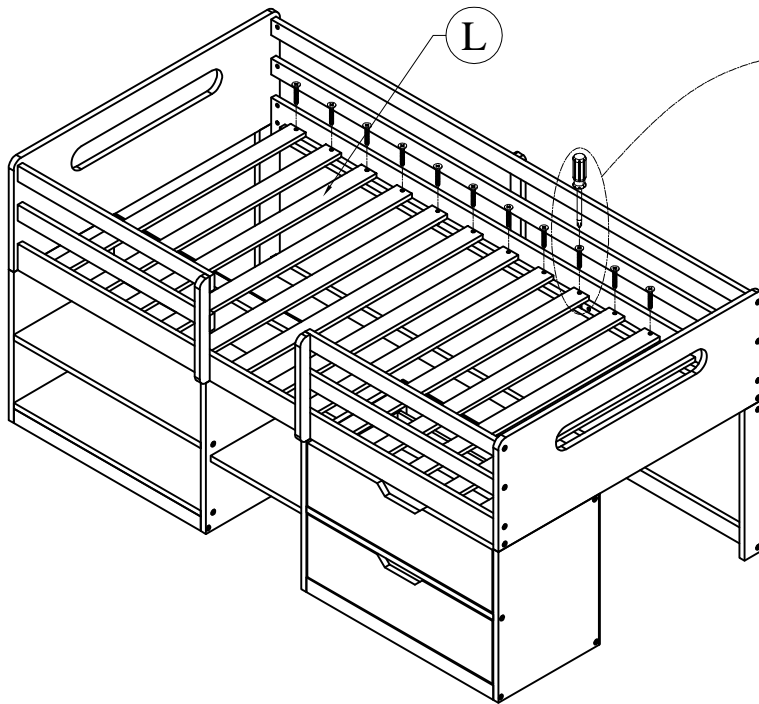

COMPLETED

