



Hayward D.E. Filter

Owner's Manual



Contents

Product Warnings.....	2
Introduction.....	4
Installation.....	4
Starting Pump and Filter.....	5
Filter Control Valve.....	6
Winterizing.....	9
Replacement Parts.....	10
Warranty.....	11
Registration.....	12

IMPORTANT SAFETY INSTRUCTIONS

Basic safety precautions should always be followed, including the following: Failure to follow instructions can cause severe injury and/or death.

⚠ This is the safety-alert symbol. When you see this symbol on your equipment or in this manual, look for one of the following signal words and be alert to the potential for personal injury.

⚠ WARNING warns about hazards that **could** cause serious personal injury, death or major property damage and if ignored presents a potential hazard.

⚠ CAUTION warns about hazards that **will** or **can** cause minor or moderate personal injury and/or property damage and if ignored presents a potential hazard. It can also make consumers aware of actions that are unpredictable and unsafe.

The **NOTICE** label indicates special instructions that are important but not related to hazards.

Hayward Pool Products
620 Division Street, Elizabeth, NJ 07207
Phone: (908) 355-7995
www.hayward.com



HAYWARD®



⚠ WARNING - Read and follow all instructions in this owner's manual and on the equipment. Failure to follow instructions can cause severe injury and/or death.

⚠ WARNING – Suction Entrapment Hazard.



Suction in suction outlets and/or suction outlet covers which are, damaged, broken, cracked, missing, or unsecured can cause severe injury and/or death due to the following entrapment hazards:



Hair Entrapment- Hair can become entangled in suction outlet cover.

Limb Entrapment- A limb inserted into an opening of a suction outlet sump or suction outlet cover that is damaged, broken, cracked, missing, or not securely attached can result in a mechanical bind or swelling of the limb.



Body Suction Entrapment- A negative pressure applied to a large portion of the body or limbs can result in an entrapment.

Evisceration/ Disembowelment - A negative pressure applied directly to the intestines through an unprotected suction outlet sump or suction outlet cover which is, damaged, broken, cracked, missing, or unsecured can result in evisceration/ disembowelment.



Mechanical Entrapment- There is potential for jewelry, swimsuit, hair decorations, finger, toe or knuckle to be caught in an opening of a suction outlet cover resulting in mechanical entrapment.

⚠ WARNING - To Reduce the risk of Entrapment Hazards:

- o When outlets are small enough to be blocked by a person, a minimum of two functioning suction outlets per pump must be installed. Suction outlets in the same plane (i.e. floor or wall), must be installed a minimum of three feet (3') [1 meter] apart, as measured from near point to near point.
- o Dual suction fittings shall be placed in such locations and distances to avoid “dual blockage” by a user.
- o Dual suction fittings shall not be located on seating areas or on the backrest for such seating areas.
- o The maximum system flow rate shall not exceed the flow rating of as listed on Table 1.
- o Never use Pool or Spa if any suction outlet component is damaged, broken, cracked, missing, or not securely attached.
- o Replace damaged, broken, cracked, missing, or not securely attached suction outlet components immediately.
- o In addition two or more suction outlets per pump installed in accordance with latest ASME, APSP Standards and CPSC guidelines, follow all National, State, and Local codes applicable.
- o Installation of a vacuum release or vent system, which relieves entrapping suction, is recommended.

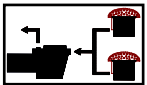

⚠ WARNING – Failure to remove pressure test plugs and/or plugs used in winterization of the pool/spa from the suction outlets can result in an increase potential for suction entrapment as described above.

⚠ WARNING – Failure to keep suction outlet components clear of debris, such as leaves, dirt, hair, paper and other material can result in an increase potential for suction entrapment as described above.

⚠ WARNING – Suction outlet components have a finite life, the cover/grate should be inspected frequently and replaced at least every SEVEN years or if found to be damaged, broken, cracked, missing, or not securely attached.

⚠ CAUTION – Components such as the filtration system, pumps and heater must be positioned so as to prevent their being used as means of access to the pool by young children. To reduce risk of injury, do not permit children to use or climb on this product. Closely supervise children at all times. Components such as the filtration system, pumps, and heaters must be positioned to prevent children from using them as a means of access to the pool.



⚠ WARNING – Hazardous Pressure. Pool and spa water circulation systems operate under hazardous pressure during start up, normal operation, and after pump shut off. Stand clear of circulation system equipment during pump start up. Failure to follow safety and operation instructions could result in violent separation of the pump housing and cover, and/or filter housing and clamp due to pressure in the system, which could cause property damage, severe personal injury, or death. Before servicing pool and spa water circulation system, all system and pump controls must be in off position and filter manual air relief valve must be in open position. Before starting system pump, all system valves must be set in a position to allow system water to return back to the pool. Do not change filter control valve position while system pump is running. Before starting system pump, fully open filter manual air relief valve. Do not close filter manual air relief valve until a steady stream of water (not air or air and water) is discharged.



⚠ WARNING – Separation Hazard. Failure to follow safety and operation instructions could result in violent separation of pump and/or filter components. Strainer cover must be properly secured to pump housing with strainer cover lock ring. Before servicing pool and spa circulation system, filters manual air relief valve must be in open position. Do not operate pool and spa circulation system if a system component is not assembled properly, damaged, or missing. Do not operate pool and spa circulation system unless filter manual air relief valve body is in locked position in filter upper body. **Never operate or test the circulation system at more than 50 PSI. Do not purge the system with compressed air.** Purging the system with compressed air can cause components to explode, with risk of severe injury or death to anyone nearby. Use only a low pressure (below 5 PSI), high volume blower when air purging the pump, filter, or piping. Use ONLY Hayward clamp system components: DEX2421JKIT clamp assembly, DEX2421J2 nut/bolt assembly, and a DEX2422Z2 metal reinforced seal. Non-Hayward components may fail in use and cause explosive separation.

Never rely on hand tightening the clamp nut to the clamp bolt. Using a 3/4” socket on a torque wrench, torque clamp nut and clamp bolt to 150 inch-lbs. Before starting system pump, insure filter manual air relief valve body is in LOCK position in filter upper body.



HAYWARD®



⚠ WARNING – Risk of Electric Shock. All electrical wiring **MUST** be in conformance with applicable local codes, regulations, and the National Electric Code (NEC). Hazardous voltage can shock, burn, and cause death or serious property damage. To reduce the risk of electric shock, do **NOT** use an extension cord to connect unit to electric supply. Provide a properly located electrical receptacle. Before working on any electrical equipment, turn off power supply to the equipment. To reduce the risk of electric shock replace damaged wiring immediately. Locate conduit to prevent abuse from lawn mowers, hedge trimmers and other equipment. Do **NOT** ground to a gas supply line.

⚠ WARNING – Risk of Electric Shock Failure to ground all electrical equipment can cause serious or fatal electrical shock hazard. Electrical ground all electrical equipment before connecting to electrical power supply.

⚠ WARNING – Risk of Electric Shock Failure to bond all electrical equipment to pool structure will increase risk for electrocution and could result in injury or death. To reduce the risk of electric shock, see installation instructions and consult a professional electrician on how to bond all electrical equipment. Also, contact a licensed electrician for information on local electrical codes for bonding requirements.

Notes to electrician: Use a solid copper conductor, size 8 or larger. Run a continuous wire from external bonding lug to reinforcing rod or mesh. Connect a No. 8 AWG (8.4 mm²) [No. 6 AWG (13.3 mm²) for Canada] solid copper bonding wire to the pressure wire connector provided on the electrical equipment and to all metal parts of swimming pool, spa, or hot tub, and metal piping (except gas piping), and conduit within 5 ft. (1.5 m) of inside walls of swimming pool, spa, or hot tub.

IMPORTANT - Reference NEC codes for all wiring standards including, but not limited to, grounding, bonding and other general wiring procedures.

⚠ WARNING – Risk of Electric Shock . The electrical equipment must be connected only to a supply circuit that is protected by a ground-fault circuit-interrupter (GFCI). Such a GFCI should be provided by the installer and should be tested on a routine basis. To test the GFCI, push the test button. The GFCI should interrupt power. Push reset button. Power should be restored. If the GFCI fails to operate in this manner, the GFCI is defective. If the GFCI interrupts power to the electrical equipment without the test button being pushed, a ground current is flowing, indicating the possibility of an electrical shock. Do not use this electrical equipment. Disconnect the electrical equipment and have the problem corrected by a qualified service representative before using.

⚠ CAUTION – HAYWARD® pumps are intended for use with permanently-installed pools and may be used with hot tubs and spas if so marked. Do not use with storable pools. A permanently-installed pool is constructed in or on the ground or in a building such that it cannot be readily disassembled for storage. A storable pool is constructed so that it is capable of being readily disassembled for storage and reassembled to its original integrity.

⚠ WARNING – Risk of Hyperthermia. To avoid hyperthermia the following “Safety Rules for Hot Tubs” are recommended by the U.S. Consumer Product Safety Commission.

1. Spa or hot tub water temperatures should never exceed 104°F [40°C]. A temperature of 100°F [38°C] is considered safe for a healthy adult. Special caution is suggested for young children. Prolonged immersion in hot water can induce hyperthermia.
2. Drinking of alcoholic beverages before or during spa or hot tub use can cause drowsiness, which could lead to unconsciousness and subsequently result in drowning.
3. Pregnant women beware! Soaking in water above 100°F [38°C] can cause fetal damage during the first three months of pregnancy (resulting in the birth of a brain-damaged or deformed child). Pregnant women should adhere to the 100°F [38°C] maximum rule.
4. Before entering the spa or hot tub, users should check the water temperature with an accurate thermometer; spa or hot tub thermostats may err in regulating water temperatures by as much as 4°F (2.2°C).
5. Persons taking medications, which induce drowsiness, such as tranquilizers, antihistamines or anti-coagulants, should not use spas or hot tubs.
6. If the pool/spa is used for therapy, it should be done with the advice of a physician. Always stir pool/ spa water before entering the pool/spa to mix in any hot surface layer of water that might exceed healthful temperature limits and cause injury. Do not tamper with controls, because scalding can result if safety controls are not in proper working order.
7. Persons with a medical history of heart disease, circulatory problems, diabetes or blood pressure problems should obtain a physicians advice before using spas or hot tubs.
8. Hyperthermia occurs when the internal temperature of the body reaches a level several degrees above normal body temperature of 98.6°F [37°C]. The symptoms of Hyperthermia include: drowsiness, lethargy, dizziness, fainting, and an increase in the internal temperature of the body.

The effects of Hyperthermia include:

1. Unawareness of impending danger.
2. Failure to perceive heat.
3. Failure to recognize the need to leave the spa.
4. Physical inability to exit the spa.
5. Fetal damage in pregnant women.
6. Unconsciousness resulting in danger of drowning.

SAVE THESE INSTRUCTIONS



HAYWARD®

GENERAL INFORMATION

Your Hayward D.E. Filter combines superior water filtration with ease of operation and totally corrosion-free construction. It uses diatomaceous earth (D.E.), which is the most efficient dirt remover and filter medium known. The D.E., which is usually fed through the skimmer at initial start-up, uniformly coats the filter elements that are covered with a custom fitted monofilament polypropylene filter cloth. As pool water is pumped through the control valve into the bottom of the filter tank, the D.E. surface, or coating, filters out even the minutest particles resulting in clear, clean, sparkling water. After a period of time, the accumulated dirt in the filter causes a resistance to flow, the pressure rises, and flow diminishes. This means the dirt holding capacity of the D.E. has been reached, and it is time to clean (backwash) your filter. With the control valve in the back wash position, the water is automatically reversed through the filter, flushing trapped dirt, debris and D.E. out the waste line. Once the filter is backwashed (cleaned) of D.E. and dirt, the control valve is manually re-sequenced to filter position and a fresh charge of D.E. is added to resume normal filtering.

	A		REQUIRED CLEARANCE			
			"B" SIDE		"C" ABOVE	
	IN	CM	IN	CM	IN	CM
DE2420	32.0	81	18	46	15	38
DE3620	34.1	87	18	46	16	41
DE4820	40.1	102	18	46	18	46
DE6020	46.1	107	18	46	22	56
DE7220	52.0	132	18	46	25	63
DEP60	34.1	87	18	46	16	41
DEP80	40.1	102	18	46	18	46
DEP100	46.1	107	18	46	22	56

INSTALLATION

⚠ WARNING



⚠ This product should be installed and serviced only by a qualified professional.

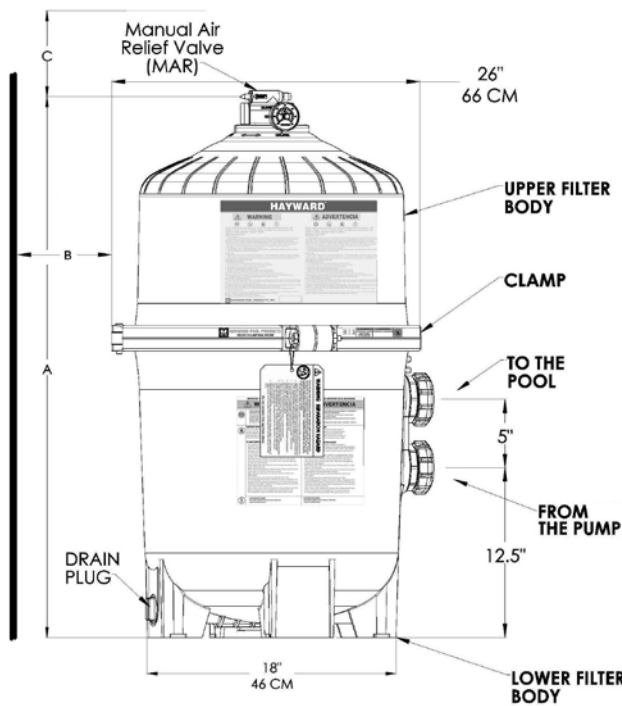

Only simple tools (screwdriver and wrenches), plus pipe sealant for plastic adapters, are required to install and/or service the filter.

1. The filter system should be installed on a level concrete slab or other rigid base. Select a well drained and vented area, one that does not flood when it rains. Position the filter so that the piping connections, and winter drain are convenient and accessible for operation, service, maintenance and winterizing.
2. Position filter so the filter will drain by gravity.
3. If practical, place pump and filter in the shade to shield it from continuous, direct heat from the sun.
4. Assemble appropriate Filter Control valve (See Page 7 for selection) to filter. Lubricate the O-ring first (we recommend using Jack's 327 Lubricant). Align the two (2) valve pipe connections, with O-rings in place, with the two openings in the side of the filter tank and press in firmly. Secure the assembly to the tank connections with the two bulkhead lock nuts. Do not over-tighten.
5. Connect the pool suction plumbing between the skimmer, pool outlet and the pump.
6. Install the pool return plumbing.
7. If pressure gauge is not installed, apply Teflon tape to the gauge threads and carefully screw the gauge into the gauge adapter assembly.
8. Do not locate pump controls over or near filter.

9. Verify water discharge from the filter manual air relief valve is directed away from electrical devices



MODEL	EFFECTIVE FILTRATION RATE		DESIGN FLOW RATE		RECOMMENDED AMOUNT OF D.E.	
	FT ²	M ²	GPM	LPM	LBS	KGS
DE2420	24	2.2	48	182	3.0	1.4
DE3620	36	3.4	72	273	4.5	2.0
DE4820	48	4.5	96	363	6.0	2.7
DE6020	60	5.6	120	454	7.5	3.4
DE7220	72	6.7	144	545	9.0	4.0
DEP60	60	5.6	120	454	6.0	2.7
DEP80	80	7.4	150	568	8.0	3.6
DEP100	100	9.3	150	568	10.0	4.5

MAXIMUM WORKING PRESSURE FOR ALL MODELS 50 PSI (3.45 BAR)

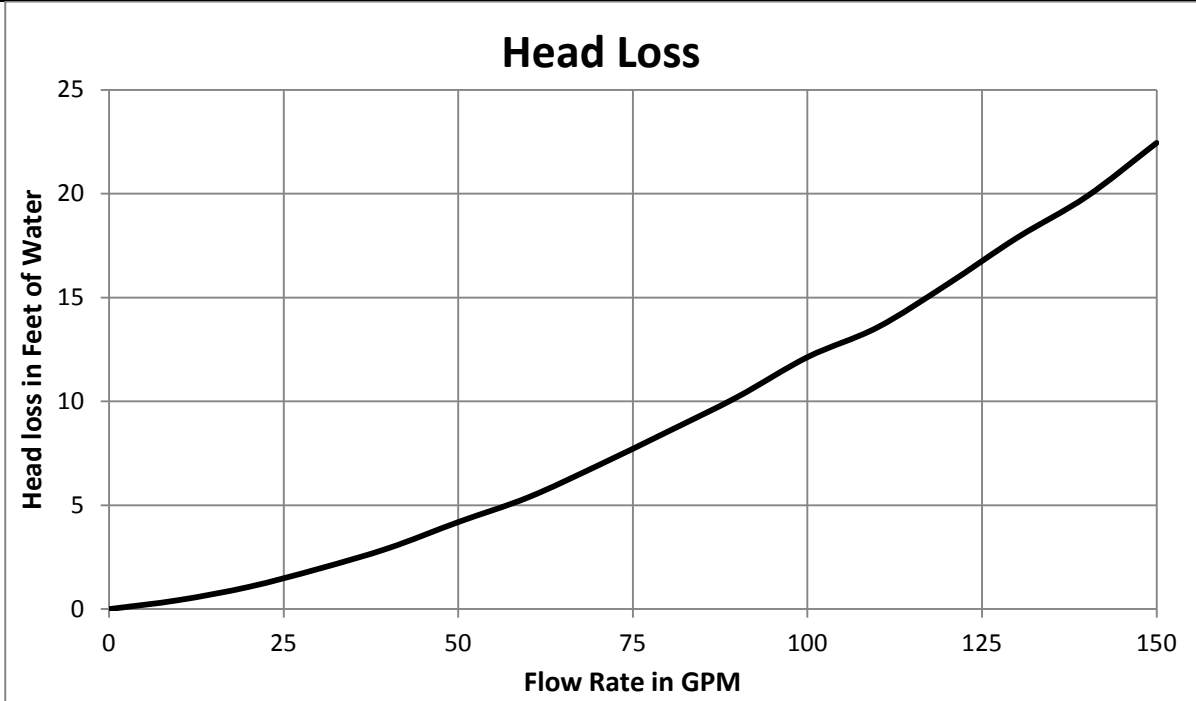



HAYWARD®

STARTING THE PUMP and FILTER SYSTEM

▲ WARNING



Before Starting the Pump

1. Use ONLY Hayward clamp system components; DEX2421JKIT clamp system, DEX2421J2 nut/bolt assembly, DEX2422Z2 metal reinforced seal. Non-Hayward clamp components may fail in use and cause explosive component separation. Verify that upper and lower filter bodies are properly secured with the filter body clamp. Never rely on hand tightening the clamp nut to the clamp bolt. Using a 3/4" socket on a torque wrench, torque clamp nut to clamp bolt to 150 inch-lbs. Verify that the filter manual air relief body is in the LOCK position, and no filter components are missing, damaged or not genuine Hayward components. (See Fig 2)
2. Close filter drain. Note: Filter plug requires an o-ring seal. (See Fig 4)
3. Open all system valves to allow water from the pool to the filtration system and from the filter to return to the pool.
4. Place the manual air relief valve in OPEN position. (See Fig 2)

Starting Pump

1. When starting system pump, do not stand over or near filter. If water leakage appears at filter tank clamp, immediately turn off all system circulation pumps and all electrical power. Do not return to the filter until all water leakage has stopped. Reassemble the clamp system per the instructions on page 7 in this owner's manual to stop leak.
2. Return to filter to CLOSE manual air relief valve only when a steady stream of water (not air or, air and water mix) is discharged from the manual air relief valve.
3. To avoid damages to the filter elements, DO NOT operate the filter for more than a minute or two without the D.E. pre-coat.

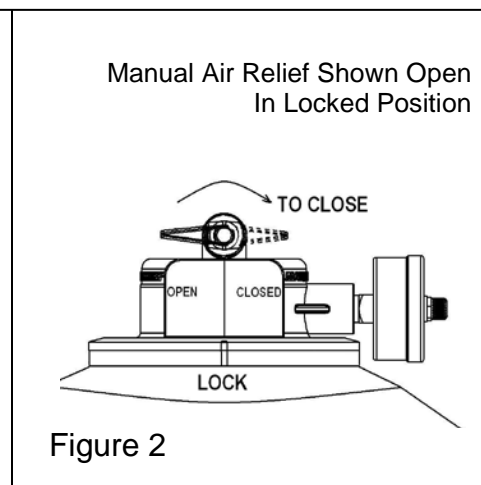
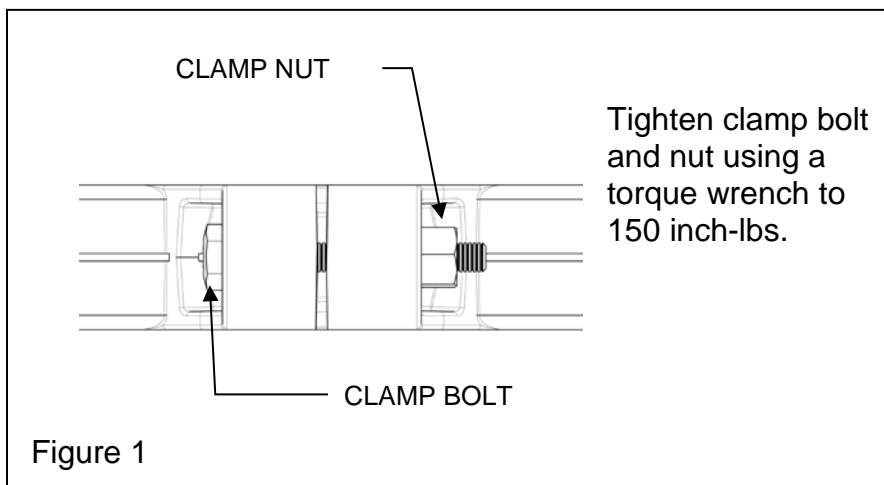

Pre-Coating

Add the correct amount of D.E. (see specifications on the previous page of this manual or on the filter label) into the system through the skimmer – as fast as the plumbing will take it. Record the pressure gauge reading after the D.E. has been added. This is the “pre-coat” or “clean” pressure.

OPERATION

▲ WARNING
FILTERING



Filtration starts as soon as the filter has been pre-coated. As the filter removes dirt from the pool water, the accumulated dirt causes a resistance to flow. As a result, the gauge pressure will rise and the flow will decrease. When the pressure rises 8-10 psi (.55-.69 bar) above the pre-coat pressure, it is time to backwash (clean) the filter. Once your filter is running and there is a pressure reading, line up the green arrow with the current reading. (See Fig 3) When the pressure rises to or above the red or second arrow, it is time to clean your filter.

Note: During initial clean-up of the pool, particularly with a new pool or a very dirty pool, it may be necessary to backwash more frequently due to the heavy initial dirt load in the water.

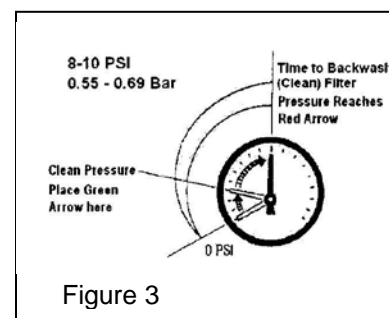



HAYWARD®

- ▲ To prevent unnecessary strain on piping system and valves, always shut off pump before switching Filter Control Valve positions.

FILTER CONTROL VALVE FUNCTIONS

Six-Position Vari-Flo™ Filter Control Valve SP0710XR50 or SP0715XR50

- (A) **FILTER** – Set valve to FILTER for normal filtering. Also use for regular Vacuuming.
- (B) **BACKWASH** –
 - a. Shut off the pump.
 - b. Set Filter Control Valve to **BACKWASH**.
 - c. Start Pump and backwash approximately two minutes, or until water out waste line appears clean.
 - d. Shut off pump.
 - e. Set Control Valve to **RINSE**.
 - f. Start pump and operate for 20 seconds.
 - g. Shut off pump.
 - h. Set Filter control valve to **FILTER**.
 - i. Proceed as in **Pre-Coating** to add fresh D.E.
- (C) **RINSE** – Water Flows through the filter the same as in FILTER position, except that the water goes to WASTE. An optimal position used for pre-coating if a large cloud (pre-coat puff) is observed returning to pool during the pre-coating process.
- (D) **WASTE** – To bypass filter for draining or lowering water level and for vacuuming heavy debris directly to WASTE.
- (E) **RECIRCULATE** – Water is re-circulated through the pool system, bypassing the filter.
- (F) **CLOSED** – Shuts off flow from pump to filter.

Four Position Selecta-Flo™ Filter Control Valve SP0740DE or SP0425

- (A) **FILTER**– Set valve to FILTER for normal filtering. Also use for regular Vacuuming.
- (B) **WASTE**– To bypass filter for draining or lowering water level and for vacuuming heavy debris directly to WASTE.
- (C) **BACKWASH**–
 - a. Shut off the pump.
 - b. Set Filter Control Valve to **BACKWASH**.
 - c. Start Pump and backwash approximately two minutes, or until water out waste line appears clean.
 - d. Shut off pump
 - e. Set Filter control valve to **FILTER**.
 - f. Proceed as in **Pre-Coating** to add fresh D.E.
- (D) **POOL OR SPA BOOST** - Water is re-circulated through the pool system, bypassing the filter.

Two-Position Slide Valve SP0410X502S

- (A) **FILTER** – Set Valve to FILTER for normal filtering. Also use for vacuuming (Handle in Down position).
- (B) **BACKWASH** –
 - a. Shut off the pump.
 - b. Set valve to **BACKWASH** (UP position).
 - c. Start Pump and backwash approximately two minutes, or until water out waste line appears clean.
 - d. Shut off pump
 - e. Set Filter control valve to **FILTER** (DOWN Position).
 - f. Proceed as in **Pre-Coating** to add fresh D.E. for cleaning filter (Handle in Up position)

MANUAL CLEANING

- ▲ Before manually cleaning the filter, backwash by following BACKWASHING instructions under each type of valve.

▲ WARNING



- ▲ This product should be installed and serviced only by a qualified professional.

FILTER DISASSEMBLY INSTRUCTIONS

1. Turn off all system circulation pumps and all electric power on the pad.
2. Set all system valves in a position to prevent water flow to the filter.
3. The manual air relief valve must be placed in the OPEN position. (FIG 6)
4. Remove filter drain plug (FIG 4) and drain water from filter.
5. Using 3/4" wrenches, loosen and remove the clamp nut and the clamp bolt. (Fig 5)
6. Holding both ends of the filter body clamp carefully spread the clamp ends. Remove the clamp by lifting over the upper filter body. Do not to drop the clamp during removal because the clamp could be damaged. Do not strike the clamp with metal tools as they can damage the clamp.
7. Lift off upper filter body. Do not use the pressure gauge to lift the upper filter body.

INITIAL CLEANING OF ELEMENT CLUSTER ASSEMBLY

Before removing the element cluster assembly we recommend hosing it down with a strong stream from a garden hose or preferably with the Hayward cleaning wand (EC2024). Be sure the drain plug is not in place or the drain valve is open. Remove as much of the dirty D.E. and accumulated debris as possible by flushing it out of the drain opening. This will allow for easier removal of the element cluster assembly.

REMOVING ELEMENT CLUSTER

Rock the element cluster assembly slightly from side to side to free the manifold from the vertical outlet elbow. The element cluster assembly may now be removed by lifting it straight up using the lift handles.

CLEANING ELEMENT CLUSTER

The filter element cluster can be cleaned by washing inside and outside with a garden hose. After hosing filter element cluster, for best results, carefully brush the surface to remove fine particles. Do Not Pressure Wash as it can damage the filter element cluster. You may find some debris on the filter element cluster, which may not have been removed with hosing.

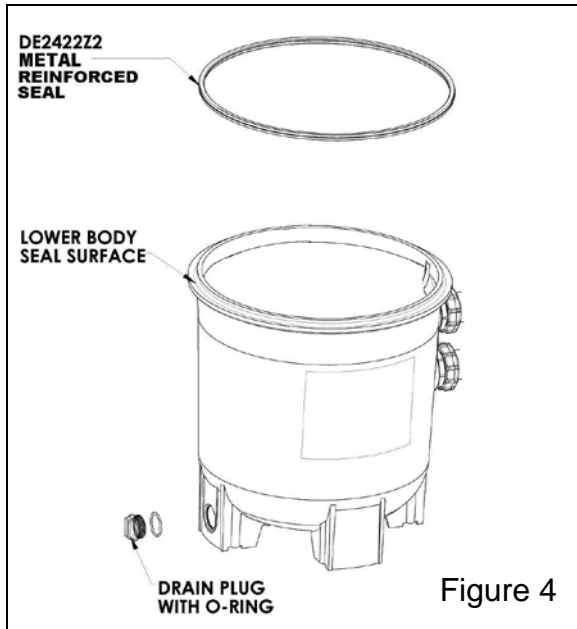

Figure 4

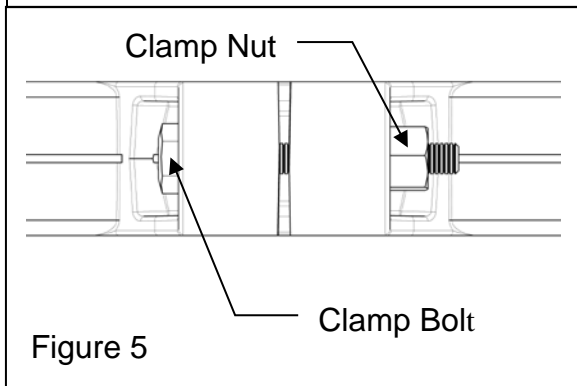

Figure 5

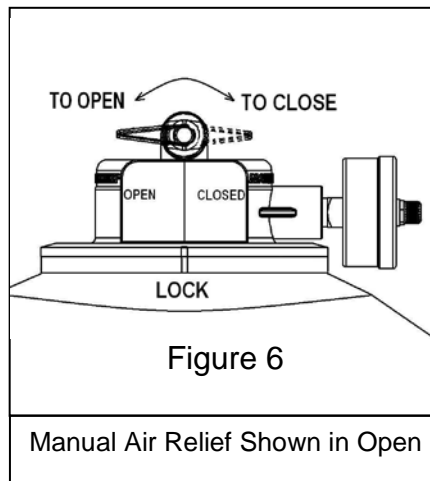

Figure 6

Manual Air Relief Shown in Open

FILTER RE-ASSEMBLY INSTRUCTIONS



CLEAN SEAL RING AND SEAL SURFACE

1. Remove filter tank seal.
2. With a clean cloth wipe the lower filter body seal surface. (Fig 4) Do not use a solvent.
3. With a clean cloth wipe the upper filter body seal surface.

Notice:

- Do not use any petroleum solvents to clean filter components.
- Do not lubricate DEX2422Z2 Seal.

RE-INSTALLING ELEMENT CLUSTER

1. Lubricate outlet elbow O-rings with Jack's Formula 327 Multilube.
2. Replace filter element cluster into filter tank, carefully fitting top collector manifold outlet over outlet elbow O-ring.



HAYWARD®

⚠ WARNING



⚠ This product should be installed and serviced only by a qualified professional.

BODY AND CLAMP RE-ASSEMBLY

1. Place the metal reinforced seal on the lower filter body (Fig 4). Place the upper filter body on the Hayward DEX2422Z2 metal reinforced seal and lower filter body in a position which allows all operation and safety labels to be clearly visible and the upper body to be centered on the lower filter body. Press down firmly and evenly to set the upper filter body. (Fig 7)
2. Replace the filter clamp around the upper and lower filter bodies. Hold the clamp ends to position the clamp on the filter bodies with the clamp ends adjacent to the safety and operation labels on the filter bodies. (Fig 7)

⚠ DO NOT HIT OR STRIKE CLAMP WITH HAMMER OR METAL TOOLS.

3. Insert clamp bolt through the clamp ends and thread the clamp nut onto clamp bolt with rounded end of the nut (Fig 8) towards the ends of the clamp.
4. Never rely on hand tightening of clamp nut to clamp bolt. Using a $\frac{3}{4}$ " socket on a torque wrench, torque clamp nut to clamp bolt to 150 inch-lbs. (Fig 9).
5. Follow Operation Instructions for "Starting the Pump and Filter System" (Page 5).

VACUUMING

Vacuuming can be performed directly into the filter whenever needed. Backwash filter after vacuuming, if required.

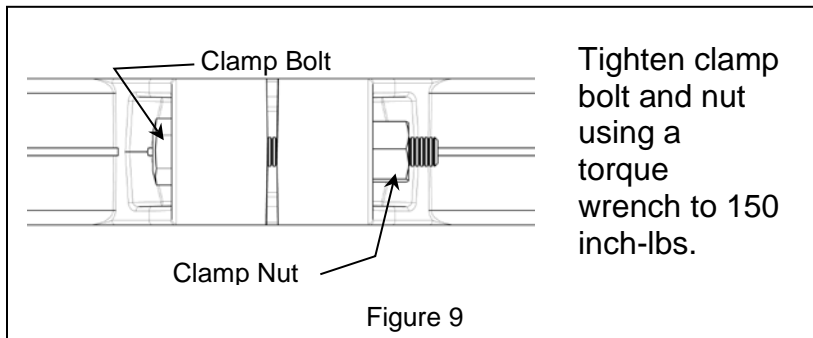
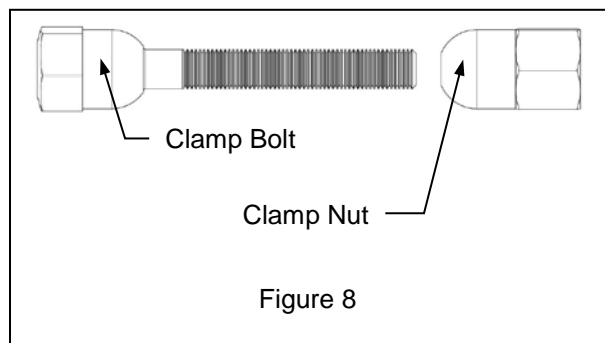
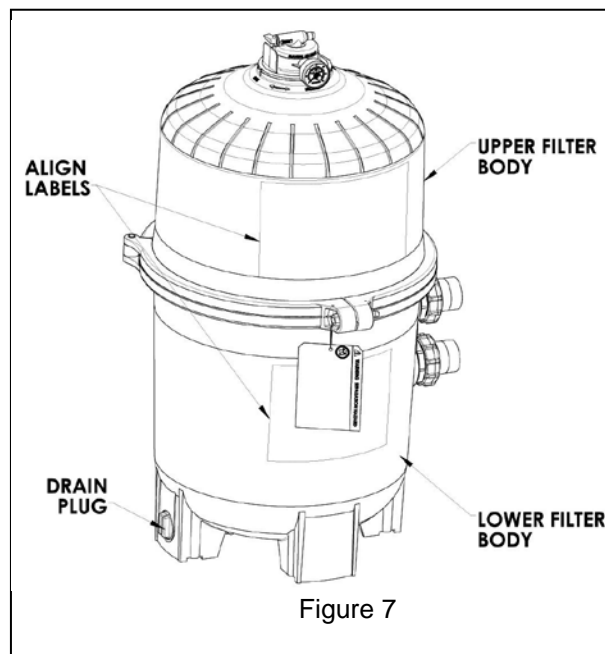

REMOVING THE MANUAL AIR RELIEF VALVE

⚠ WARNING



Your Filter comes with a Manual Air Relief Valve (MAR) pre-installed from the factory.

⚠ **Only qualified pool professionals should service your filter's Manual Air Relief Valve.**

For Qualified pool professionals only: If MAR valve needs to be serviced, follow these instructions carefully.

1. Turn off all system circulation pumps and all electric power on the pad.
2. Set all system valves in a position to prevent water from flowing to the filter.
3. The manual air relief valve must be placed in the OPEN position.
4. Wait until all water leakage has stopped.
5. Grasp the MAR body at the flats, turn the MAR counterclockwise until the indicator on the on the MAR flange is aligned with the "UNLOCK" position on the upper filter body.
6. Pull straight up to remove the MAR, a slight rocking motion may help.

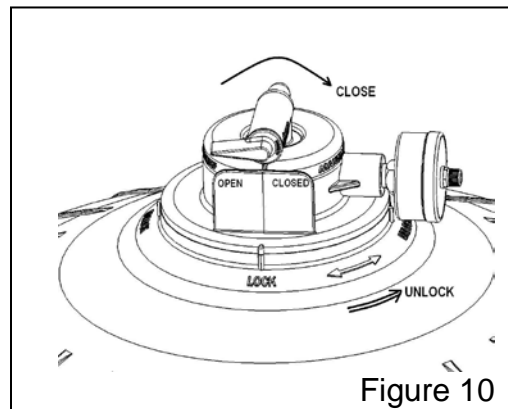

Figure 10

Manual Air Relief Shown Open
In Locked Position
Rotate counterclockwise to UNLOCK

RE-INSTALLATION OF THE MANUAL AIR RELIEF VALVE

1. Check the o-ring seals, replace as needed.
2. With a clean cloth, wipe upper filter body and o-ring groove. Remove all dirt and debris.
3. Align the notch in the MAR Flange with notch on top of the upper filter body.
4. Press the MAR straight down into the upper filter body
5. Turn the MAR clockwise until the indicator is aligned with the "LOCK" position on the upper filter body.
6. Verify the MAR discharge points away from all electrical connections.

WINTERIZING FILTER

⚠ In areas where subfreezing temperatures can be expected, the filter should be drained to protect the filter from damage.

1. The filter should be disassembled and the filter elements cleaned or replaced.
2. Follow directions under FILTER DISASSEMBLY INSTRUCTIONS
3. Then REMOVE FILTER ELEMENTS per instructions
4. Reassemble per the instructions on Page 8.
5. Be sure to leave the drain plug unattached during the winter season to avoid cracking the filter body.

SERVICE AND REPAIRS

Consult your local authorized Hayward dealer or service center. No returns may be made directly to the factory without the expressed written authorization of Hayward Pool Products.

SUGGESTED POOL CHEMISTRY LEVELS	
pH	7.2 to 7.8
TOTAL ALKALINITY	80 to 120 ppm
CALCIUM HARDNESS	200 to 400 ppm
COMBINED CHLORINE	.2 ppm Maximum
CHLORINE (STABILIZED)	1.0 to 3.0 ppm
CHLORINE STABILIZER (Cyanuric Acid)	60 to 80 ppm

PROBLEM SOLVING LIST

REMEDY	LOW WATER FLOW	SHORT FILTER CYCLES	POOL WATER WON'T CLEAR UP
	<ol style="list-style-type: none"> 1. Check skimmer and pump strainer baskets for debris. 2. Check for restrictions in intake and discharge lines. 3. Check for air leak in intake line (indicated by bubbles returning to pool). 4. Backwash (Clean) Filter 	<ol style="list-style-type: none"> 1. Check for algae in pool and super-chlorinate as required. 2. Be sure chlorine and pH levels are in proper range (adjust as required). 	<ol style="list-style-type: none"> 1. Check chlorine, pH and total alkalinity levels and adjust as required. 2. Be sure flow rate through filter is sufficient. 3. Operate filter for longer periods.



HAYWARD®

Parts Listing

ITEM	Part No.	Description
1	CCX1000V	Manual Air Relief w/O-ring
2	DEX2420MAR2	Manual Air Relief Assembly
3	ECX2712B1	Pressure Gauge
4	DEX2420Z8A	O-Ring Kit (Set of 2)
5	CCX1000N	Manual Air Relief Nut
6	DEX2420BTC	Filter Head w/Clamp DE2420
	DEX3620BTC	Filter Head w/Clamp DE3620
	DEX4820BTC	Filter Head w/Clamp DE4820
	DEX6020BTC	Filter Head w/Clamp DE6020
	DEX7220BTC	Filter Head w/Clamp DE7220
7 (28)	DEX2420LA6PAK	Label Pack*
8	DEX2421KIT	Clamp System including: Clamp, Clamp nut and Bolt, Hang tag, Metal Reinforced Seal and Labels
		Clamp Bolt and Nut
9	DEX2421J2	Clamp Bolt and Nut
10	DEX2420LA6PAK	Label Pack*
11	DEX2422Z2	Metal Reinforced Seal
12	ECX176865	Retainer Nut 5/16"-18
13	ECX1109	Washer (2 Required)
14	DEX2400C	Top Collector Manifold
15	DEX2400R	Retainer Rod DE2420
	DEX3600R	Retainer Rod DE3620
	DEX4800R	Retainer Rod DE4820
	DEX6000R	Retainer Rod DE6020
	DEX7200R	Retainer Rod DE7220
16	DEX2400CR	Flex Air Relief Assembly
17	DEX2400Z5	Outlet Elbow O-ring
18	DEX2420EA	Outlet Elbow DE2420
	DEX3620EA	Outlet Elbow DE3620
	DEX4820EA	Outlet Elbow DE4820
	DEX6020EA	Outlet Elbow DE6020
	DEX7220EA	Outlet Elbow DE7220
19	DEX2420DC	Filter Element Cluster Assembly (Complete set of elements, collectors, Locators, Manifold, ect.)
	DEX3600DC	
	DEX4800DC	
	DEX6000DC	
	DEX7200DC	
20	DEX2400DA	Filter Element (7 Required)
	DEX3600DA	
	DEX4800DA	
	DEX6000DA	
	DEX7200DA	
21	DEX2400DS	Filter Element Short (1 Required)
	DEX3600DS	
	DEX4800DS	
	DEX6000DS	
	DEX7200DS	
22	DEX2420GA	Inlet Diffuser
23	DEX2420T	Element Spacer (DE2420 Only)
24	DEX2400H	Filter Element Locator
25	SX220Z2	Bulkhead O-Ring (2 Req.)
26	DEX2420F	Bulkhead Fitting (2 Req.)
27	DEX2420ATC	Filter Body w/Clamp
29	SP1022C	1 1/2" Drain Plug w/ O-Ring
30	DEX2420DCKIT	Strap Kit (Optional) 2 straps, 2 Screws
31	SX200Z4	O-Ring (2 Req.)
32	SP0740DE	Selecta-Flo™ Valve 2" SKT
	SP0710XR50	Vari-Flo™ Valve 1 1/2" NPT
	SP0715XR50	Vari-Flo™ Valve 2" NPT
33	SP0410X5025	Slide Valve 2" SKT

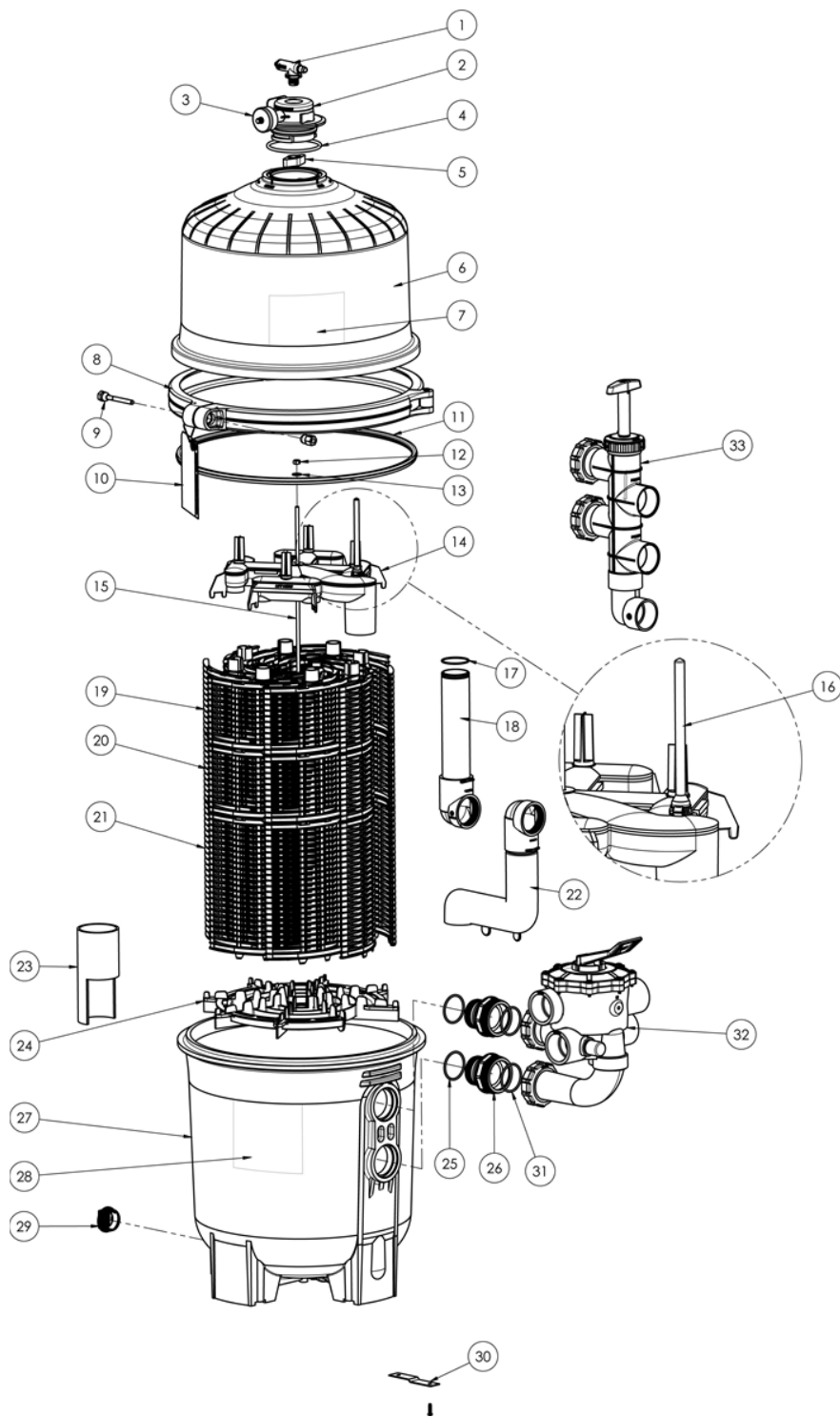

*Label Pack: Includes all Warning and Operation Labels, Hang Tag, Wire Tie and Owner's Manual



HAYWARD®

ITEM	PART NUMBER	DESCRIPTION
1	ECX2712B1	Pressure Gage
2	DEX2420Z8A	O-Ring Kit (Set of 2)
3	CCX1000N	Air Relief Valve Nut
4	CCX1000V	Manual Air Relief w/O-Ring
5	DEX2420MAR2	Manual Air Relief Assembly
6a	DEX3620BTC	Upper Filter Body DEP60
6b	DEX4820BTC	Upper Filter Body DEP80
6c	DEX6020BTC	Upper Filter Body DEP100
7	DEX2421J2	Clamp Bolt & Nut
8	DEX2421JKIT	Clamp System Including: Clamp, Clamp Nut and Bolt, Hang Tag, Metal Reinforced Seal, and Labels
9	DEX2422Z2	Metal Reinforced Seal
10	CX3030C	Top Manifold
11	CX3000J1	Air Relief Filter
12	CX2030Z3	Air Relief Tube
13a	DEX150E	Cartridge Element DEP60 1 of 4 Required
	DEX150EPAK4	Cartridge 4 Pack DEP60
13b	DEX200E	Cartridge Element DEP80 1 of 4 Required
	DEX200EPAK4	Cartridge 4 Pack DEP80
13c	DEX250E	Cartridge Element DEP100 1 of 4 Required
	DEX250EPAK4	Cartridge 4 Pack DEP100
14	DEX2400Z5	O-Ring
15a	DEX6040EA	Outlet Elbow Assembly DEP60
15b	DEX8040EA	Outlet Elbow Assembly DEP80
15c	DEX10040EA	Outlet Elbow Assembly DEP100
16	CX3020FB	Inlet Elbow
17	CX3030D	Bottom Seal Plate
18	DEX2420ATC	Lower Filter Body
19	DEX6040LA6PAK	Label Pack: Includes all Warning and Operation Labels, Hang Tag, Wire Tie, and Owner's Manual
20	SP1022CBLK	1 1/2" Drain Plug w/O-Ring
21	SX220Z2	O-Ring
22	DEX2420F	Bulkhead Fitting
23	DEX2420DCKIT	Strap Kit (Optional)
24	SP0425	SelectaFlo Valve

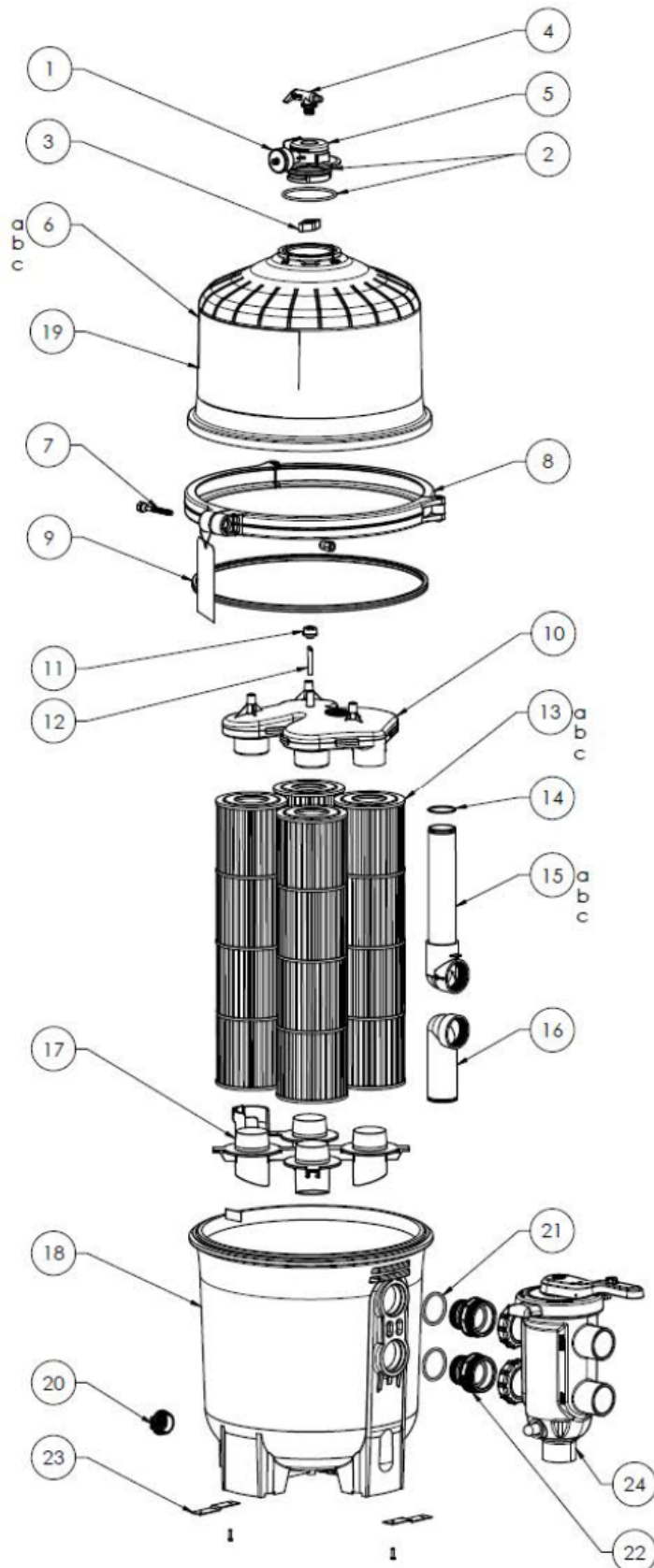



HAYWARD LIMITED WARRANTY

To buyer, as original purchaser of this equipment, Hayward Pool Products, 620 Division Street, Elizabeth, New Jersey, warrants its products to be free from defects in materials and workmanship for a period of (see below) from the date of purchase.

Parts which fail or become defective during the warranty period, except as a result of freezing, negligence, improper installation, use, or care, shall be repaired or replaced, at our option, without charge, within 90 days of the receipt of defective product, barring unforeseen delays.

To obtain warranty replacements or repair, defective components or parts should be returned, transportation paid, to the place of purchase, or to the nearest authorized Hayward service center. For further Hayward dealer or service center information, contact Hayward customer service department. No returns may be made directly to the factory without the express written authorization of Hayward pool Products.

To original purchasers of this equipment, Hayward Pool Products warrants its products to be free from defects in materials and workmanship for a period of (see below) from the date of purchase.

Filters which become defective during the warranty period, except as a result of freezing, negligence, improper installation, use or care, shall be repaired or replaced, at our option, without charge,

All other conditions and terms of the standard warranty apply.

Hayward shall not be responsible for cartage, removal and/or reinstallation labor or any other such costs incurred in obtaining warranty replacements.

The Hayward Pool Products warranty does not apply to components manufactured by others. For such products, the warranty established by the respective manufacturer will apply.

Some states do not allow a limitation on how long an implied warranty lasts, or the exclusion or limitation of incidental or consequential damages, so the above limitation or exclusion may not apply to you.

This warranty gives you specific legal rights, and you may also have other rights, which vary from state to state.

Product Line	Warranty Period
Standard Line	One (1) year
Expert line	Two (2) years

***Supersedes all previous publications.**

**Hayward pool Products
620 Division Street
Elizabeth, NJ 07207**

