

# BESSEY® Auto-Adjust Toggle Clamps

## STC-IHA15 Horizontal, angled base plate



Simply better.

### Features

- 1 Auto-Adjust** The BESSEY® Auto-Adjust Toggle Clamp automatically adjusts to variations in work piece dimensions while maintaining constant clamping force.
- 2 Adjustable Clamping Force** The integrated clamping force adjustment screw can be used to vary the applied clamping force in a wide range.
- 3 Adaptable Base Plate** Holes are sized and spaced for easy mounting and flexibility.
- 4 Large Handle** Soft insets for maximum comfort.



### Benefits

One BESSEY® Auto-Adjust Toggle Clamp offers a range of clamping force and clamping height. It can replace a range of competitive clamps for quicker set-ups, smaller tool cribs and consolidated inventories.

Model #	Opening	Nominal Clamping Force Range	Holding Capacity	Approx. Weight	Fastener
STC-IHA15	3/8"	25 - 250 lbs.	450 lbs.	0.55 lbs.	3/16" or M5

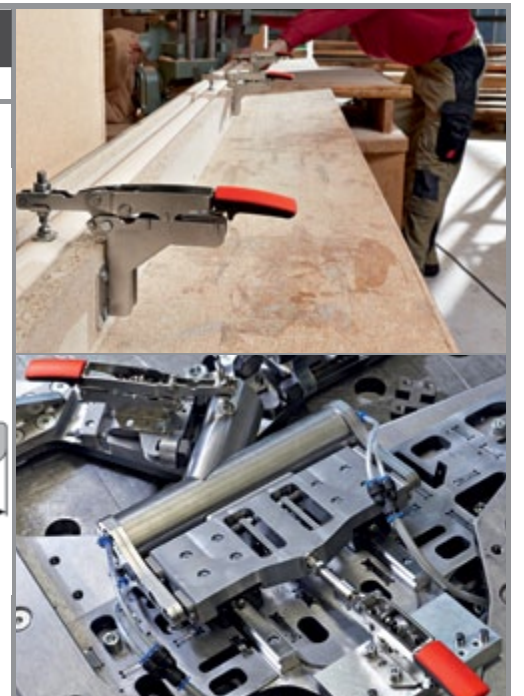
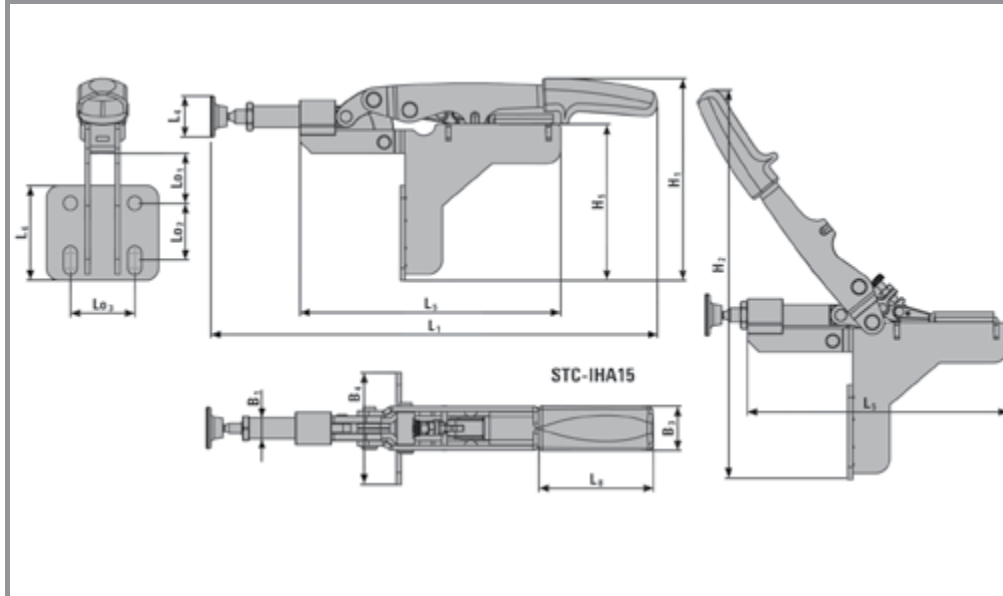

	Total Length	Length of extension arm	Spindle adjustment range	Pressure plate diameter	Length of base	Length of base plate 1	Length of base plate 2	Length of 2 - comp handle	Height of handle (closed)	Height of handle (open)	Height of extension arm	Height of spindle, cpl.	Height of base	Width of extension arm (external)	Width of extension arm (internal)	Width of 2-comp. handle	Width of base plate	Length of hole spacing 1	Length of hole spacing 2	Length of hole spacing 3	Width of elongated hole	Diameter of hole
STC-IHA15	L1	L2	L3	L4	L5	L6	L7	L8	H1	H2	H3	H4	H5	B1	B2	B3	B4	Lo1	Lo2	Lo3	Lo4	Ø
	7.13"	-	-	0.63"	4.13"	-	-	1.81"	3.19"	5.87"	-	-	2.48"	0.33"	-	0.79"	1.77"	1.00"	0.79-1.00"	1.00"	-	0.22"

\* Variable and dependent on spindle settings, pressure screw setting, force applied etc. Some small spindle adjustments may be required to achieve maximum clamping opening.

Rev. Mar 2013



Toggle Video



E-Newsletter Sign up

