

Limited Lifetime Warranty

Knape & Vogt Manufacturing Company guarantees its drawer slides and builder's hardware products against failure or defects for so long as the purchaser or end user owns them. This warranty is void if any damage to the product is due to misuse, neglect, accident, improper installation or any uses contrary to the instructions accompanying the product. This warranty covers the cost of the defective part and not the cost of removal, installation or other incidental charges. The foregoing are the purchaser's exclusive remedies. Knape & Vogt Manufacturing Company assumes no liability for special or consequential damages.

Replacement product may be obtained by returning the product, transportation charges prepaid, together with a receipt of purchase or other documents acknowledging the sale of the product to the Knape & Vogt Manufacturing Company, Attention: Customer Service Department.

The warranty set forth above is in lieu of any other warranties, express or implied, including warranties of merchantability and fitness for use.



Knape & Vogt Manufacturing Company
2700 Oak Industrial Drive NE, Grand Rapids, MI 49505
800.253.1561 • 616.459.3311 • fax 616.459.3290
www.knapeandvogt.com

© 2002 Knape & Vogt Manufacturing Company.

Manufacturer reserves the right to change specifications without notice and without incurring responsibility for existing units.

Patents Pending

300942/1002

KV 8090 Series

4x4 Pocket Door™ Slide Cassette Roller (8090P CR)

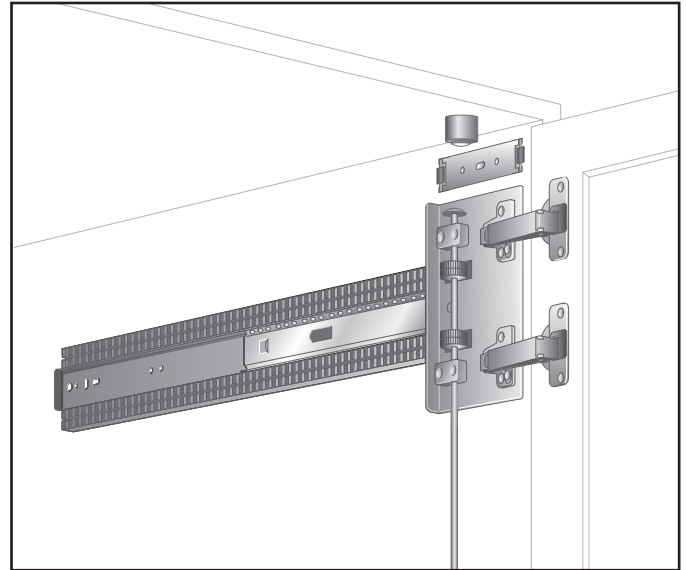

Installation Instructions for the KV 8090 Series 4x4 Pocket Door™ Raised Panel Cassette Roller

READ INSTRUCTIONS FIRST!

These instructions show how to install the KV 8090 Cassette Roller. Please note that improper installation may void the Knape & Vogt Limited Lifetime Warranty. To install the cassette roller correctly, follow the following instructions, use only KV hardware and make no modifications. If you have questions or need additional information, please contact Knape & Vogt customer service.

Step 1. Determine the set back for the cassette roller

Set back will be equal to the door thickness plus 1/4".

Step 2. Determine the centerline of the cassette roller

Locate the centerline of the cassette roller the same as the approximate centerline of the top and bottom door frame rail.

Step 3. Secure the cassette roller with enclosed screws

