

POT & PAN PANTRY ORGANIZER

Installation Instructions

Inspect all parts and read all instructions prior to beginning assembly and installation.

1 Install Front Bracket Screws

Mark bottom side of top face frame rail at 7-3/4" from center on both the left and right sides. Mark should be 3/8" from front edge of frame rail. Using 1/16" drill bit, drill pilot holes in both marks. Insert 1 - #8 x 1/2" sheet metal screw into each hole and tighten 2-3 turns. Do not tighten completely.

2 Locate Rear Mounting Bracket Screw Positions on Back Wall

Locate the center of the back wall of the cabinet. Measure 6-1/2" from the center on both sides and make a small vertical line (A). Find the distance from the top of the cabinet to the bottom edge of the upper face frame rail (B). Add 7/8" to measurement B and mark horizontal line (C) with pencil so that it crosses line A. Repeat on other side. Drill a pilot hole with 1-1/6" drill bit in both locations where A and C intersect.

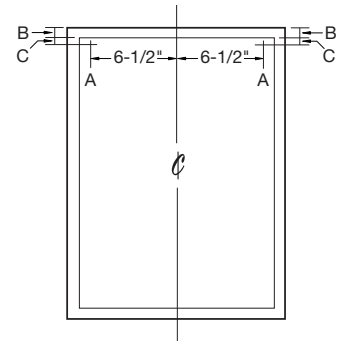

3 Mount Rear Mounting Brackets to Slides

3A. Measure from the interior back wall of the cabinet to the front edge of the cabinet face frame (D). Subtract 3-9/16" from measurement D to get measurement E.

3B. Fully extend both slides on pan rack assembly. Choose either the left or right slide. Using measurement E, measure from the front edge of the face frame bracket down the outside of the slide and make a horizontal line. Slide the rear mounting bracket on to the slide until the front edge of the bracket lines up with the line. Using 1 - #8 x 3/16" machine screw fasten rear mounting bracket to slide. Repeat for the other slide.

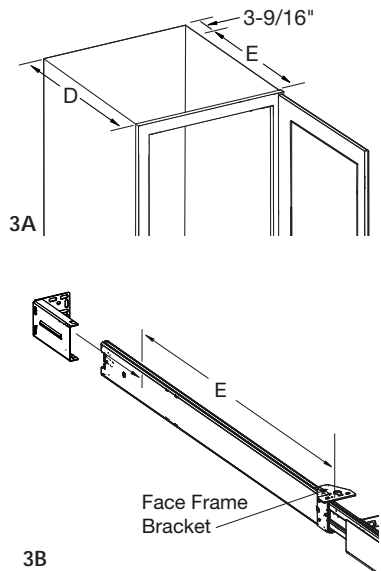

4 Mount Unit to Cabinet

4A. Lift pan rack assembly into position and insert the two front bracket screws from step one into the eye holes on both the left and right face frame brackets.

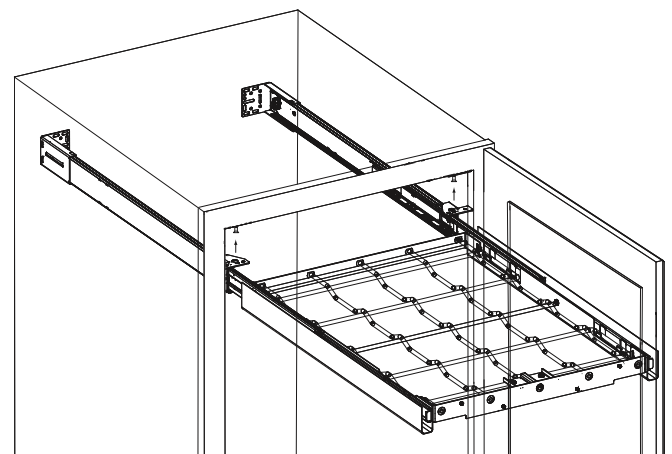

Parts Included

- A. Pan Rack Assembly (1)
- B. Wood Fascia (1)
- C. Handle (1)
- D. Rear Mounting Brackets (2)
- E. Pan Hooks (6)
- F. Rubber Grommets (6)
- G. #8 x 1/2" Sheet Metal Screws (8)
- H. #8 x 3/16" Machine Screws (2)
- I. #10 x 3/8" Machine Screws (4)

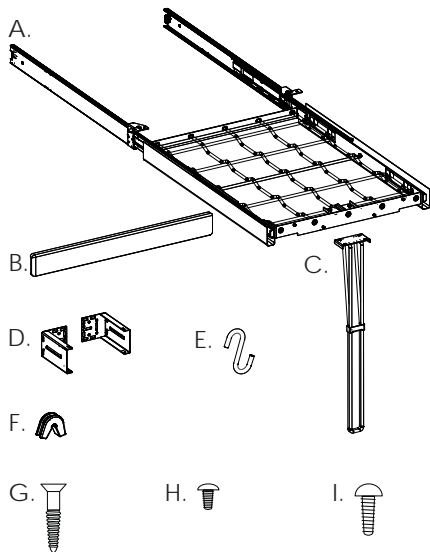

Tools Required

- Phillips head screwdriver
- Drill with 1/16" (1.5mm) bit for drilling pilot holes
- Tape measure or ruler
- Pencil

Product Assemblies

PAN1700TM



KNAPE & VOGT.

4B. Lift rear of pan rack assembly up until shaded hole on rear mounting bracket (4B) lines up with both pilot holes. Screw 1 – #8 x ½" sheet metal screw into each pilot hole so they are secure. Choose any round hole on each rear mounting bracket and screw 1 – #8 x ½" sheet metal screw into each bracket so they are secure.

4C. Fully tighten the two front face frame bracket screws so they are secure. Screw 1 – #8 x ½" sheet metal screw through any of the round holes in each of the two front brackets so they are secure.

5 Install Handle

Place handle facing outward on the bottom of the handle mounting bracket with handle bracket facing upward. Using 4 – #10 x 3/8" machine screws, screw handle into place.

6 Install Wood Fascia

Position wood fascia in front of pan rack assembly so that mounting fasteners line up with holes in front of pan rack assembly. Press wood fascia firmly into pan rack assembly until it is secured tightly.

7 Install Hooks

Refer to installation instructions in hook kit.

Unit is now fully assembled.

