

DEPENDENTLY ROTATING HARDWARE

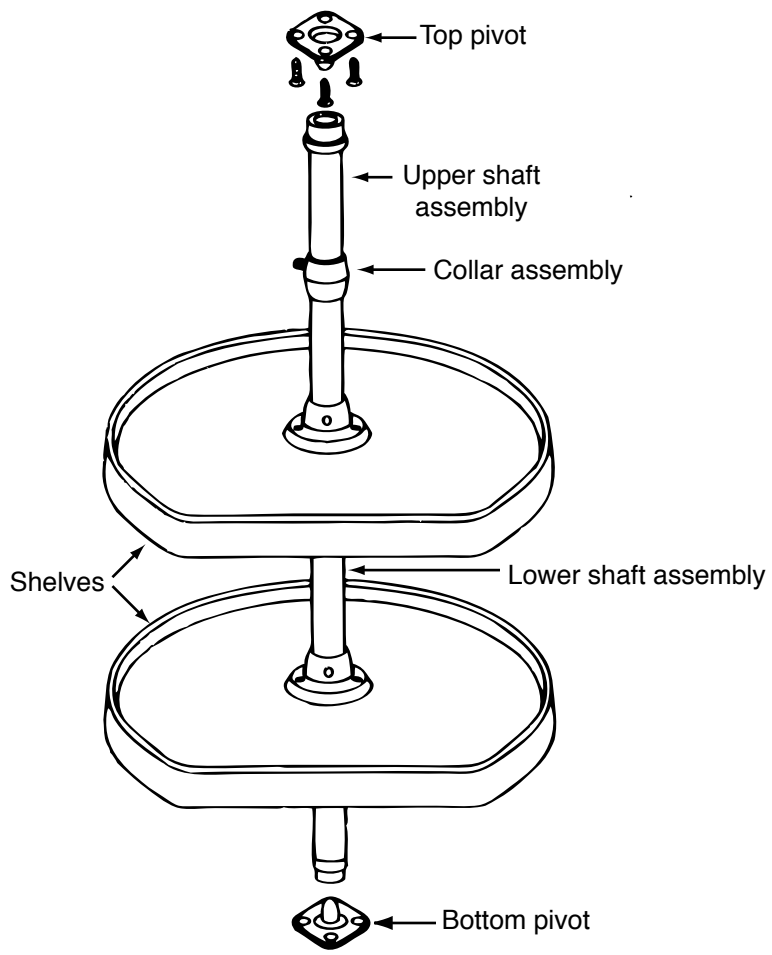

INDEPENDENTLY ROTATING HARDWARE

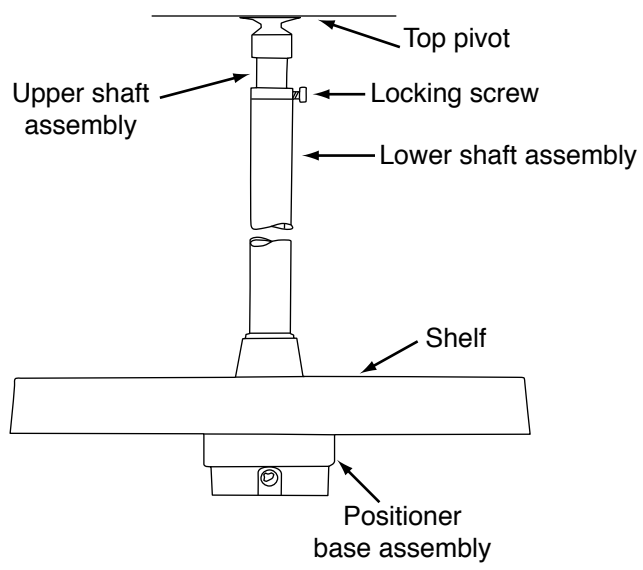

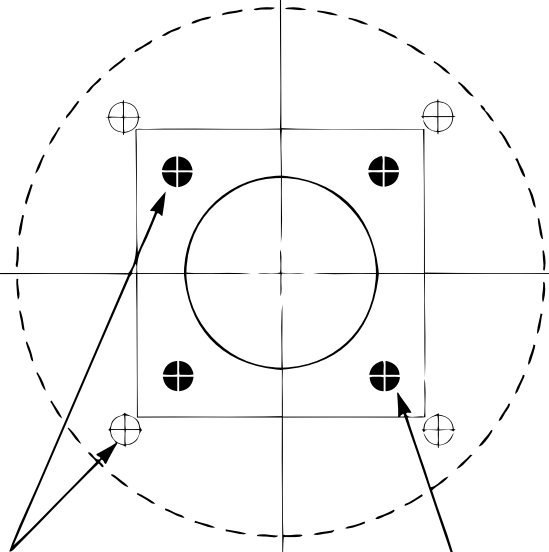

**6272/6273
INDEPENDENT ROTATING**

Utilize four outside holes for bottom positioner base assembly and four inside holes for top pivot bracket

**7012/7013
DEPENDENT ROTATING**

Utilize four outside holes to drill for positioning top AND bottom pivot brackets

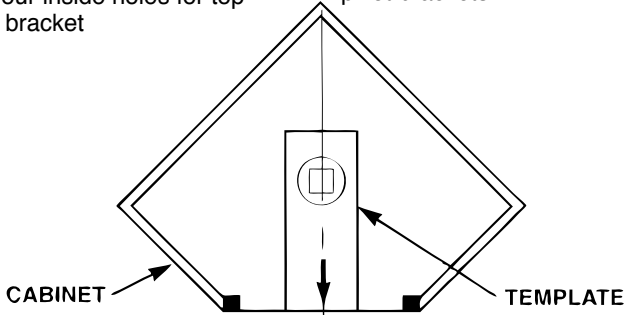

CABINET CENTERLINE

Locate on centerline of cabinet along front opening

REV•A•SHELF 20" D-shape polymer tray set template

Located centerline of cabinet width. Place template on top or bottom of cabinet with arrow pointed toward the front. Align edge of template with front of the cabinet. Line up centerline of template with center line of cabinet and spot mounting holes, using 1/8" diameter drill or equivalent.

20"

D-SHAPE

FORM #6272-20



FRONT OF CABINET