

## Air - the truly concealed hinge



Air is an innovative and functional concealed hinge system, characterized by sophisticated design, compactness and very high performance qualities.

Like traditional hinges, Air is fully adjustable in three directions and also incorporates an integrated Soft Close mechanism for soft closing doors or the Push self-opening system for handle-less doors.

With a height of only 10mm, Air is recessed into the cabinet and the door and is practically invisible.

It can be used both with wood doors and aluminum framed doors. Whether used on small light doors or tall heavy doors, 2 hinges are all that is required to ensure a smooth and worry free action.

Air is also available in Titanium finish and suitable for numerous applications: kitchens, bathrooms, living areas and bedroom furniture or display cabinets.

Compact, stylish and elegant.

Air is the new fusion of technology and aesthetics.





**Technical features**

**Air hinges are offered with integrated soft close mechanism or Push opening. They are attached to the top and bottom panel of the cabinet.**

For min. 18 mm (3/4") thick wood doors and for aluminum-framed doors.  
 Max. door weight 20 Kg (44 lbs).  
 Max. dimensions of the door : height 2100 mm (84"), width 610 mm (24").  
 16.5 mm deep metal cup.  
 L = 2.5 mm  
 105° opening.  
 Possible drilling distance on the door (K): from 3 mm (1/8") to 6 mm (1/4") for wood doors.  
 Fixed K = 4 mm for aluminum-framed doors (DEL6LP300\_).

**Space needed to open the door**

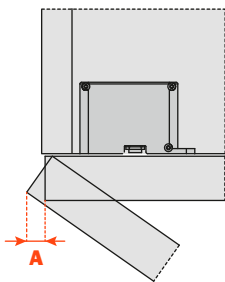

T=	18	20	22	24	26	28	30	32
K=3 <b>A=</b>	0	0.2	0.5	0.8	2.3	4.9	7.5	10.0
K=4 <b>A=</b>	0	0.2	0.4	0.8	1.3	3.9	6.5	9.0
K=5 <b>A=</b>	0	0.2	0.4	0.8	1.3	2.9	5.5	8.0
K=6 <b>A=</b>	0	0.2	0.4	0.8	1.2	1.9	4.5	7.0

**The above values are calculated on the assumption that the doors have square edges. They are reduced if the doors have radiused edges.**

**Projection of the door**

Projection of the door from the cabinet side at the max. opening.  
 The figures are based on K value = 3 mm (1/8") and door overlay = 19.5 mm (3/4").

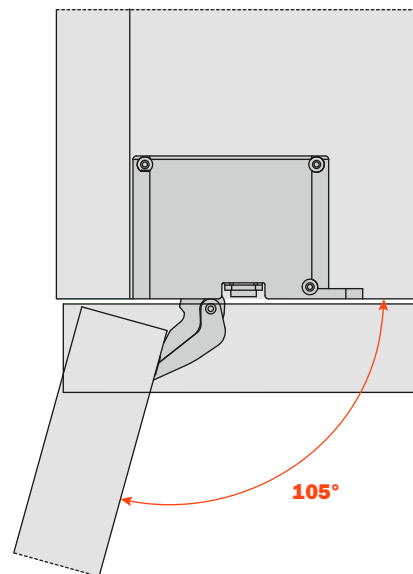
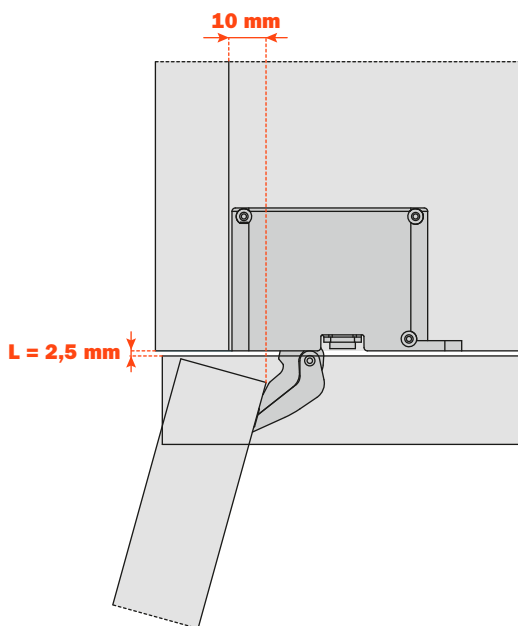

**SET PACKING (poly-bag)**

Closing Opening	Nickel finish	Titanium finish	Packaging
Soft close	<b>CEL6XE9XXV</b>	<b>CEL6XE6XXV</b>	Box 12 bags Cartons 72 bags
Push	<b>CELPX99XXV</b>	<b>CELPX66XXV</b>	1 bag contains: 2 hinges and wood screws 2 #8 x 1" wood screws/Pozi drive 4 #6 x 5/8" wood screws/Pozi drive

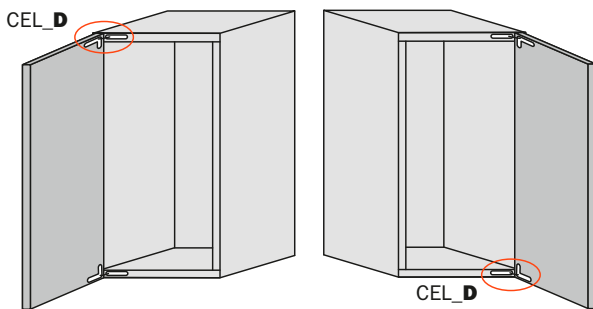

**CEL\_D** is marked **R**  
**CEL\_S** is marked **L**

For a left hand opening door, use a **CEL\_D** on the top and **CEL\_S** on the bottom.

For a right hand opening door, use a **CEL\_D** on the bottom and a **CEL\_S** on the top.

**INDUSTRIAL PACKAGING**

\*Special order

Closing Opening	Nickel finish	Titanium finish	Packaging
Soft close	<b>CEL6DE9XXI</b>	<b>CEL6DE6XXI</b>	Cartons 100 pcs.
Push	<b>CELPD99XXI</b>	<b>CELPD66XXI</b>	Wood screws included #8 x 1" wood screws/Pozi drive #6 x 5/8" wood screws/Pozi drive

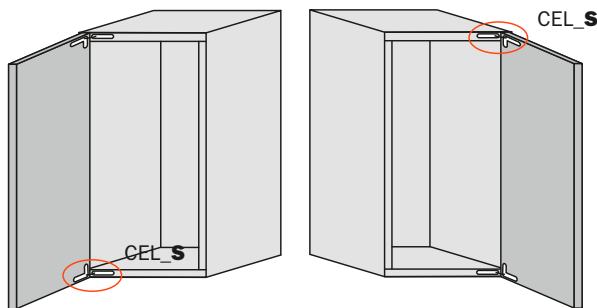

**CEL\_D** is marked **R**  
**CEL\_S** is marked **L**

For a left hand opening door, use a **CEL\_D** on the top and **CEL\_S** on the bottom.

For a right hand opening door, use a **CEL\_D** on the bottom and a **CEL\_S** on the top.

Closing Opening	Nickel finish	Titanium finish	Packaging
Soft close	<b>CEL6SE9XXI</b>	<b>CEL6SE6XXI</b>	Cartons 100 pcs.
Push	<b>CELPS99XXI</b>	<b>CELPS66XXI</b>	Wood screws included #8 x 1" wood screws/Pozi drive #6 x 5/8" wood screws/Pozi drive



Corner connectors (L & R) for frame assembly of the doors and hinge mounting.

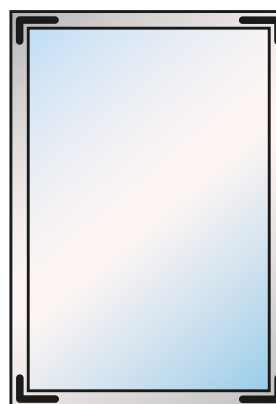

Part number	Packing
<b>DEL6BSFV02</b>	Boxes 25 bags 1 bag contains: 4 corner connector and machine thread assembly screws in Nickel & Titanium

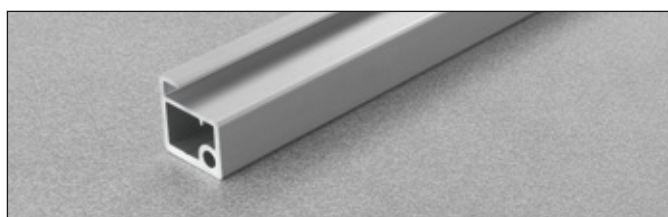

Frame for glass insertion (4 mm thickness).

Part number	Packing	Length
<b>DEL6LP300P</b>	12 frames anodized aluminum.	3 m (9'-10")
<b>DEL6LP300T</b>	12 frames Titanium	3 m (9'-10")

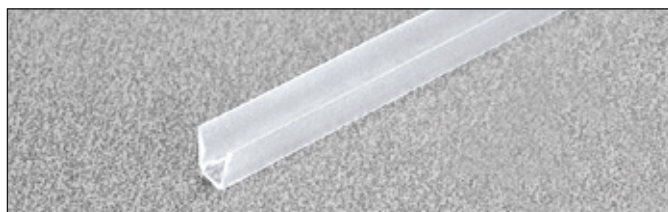

Gasket for glass.

Part number	Packing	Length
<b>D206AG3000</b>	12 gaskets	3 m (9'-10")



Angle reduction clip to reduce the opening to 92°.



Part number	Packing
<b>SEL637X3</b>	Cartons 500 pieces

## Aluminum frame assembly

Assemble with the Nickel or Titanium machine screws provided in the sets.

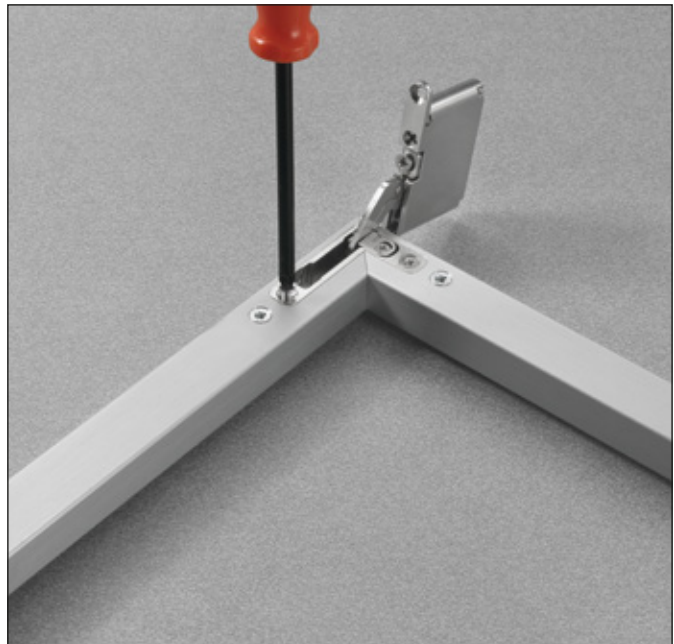
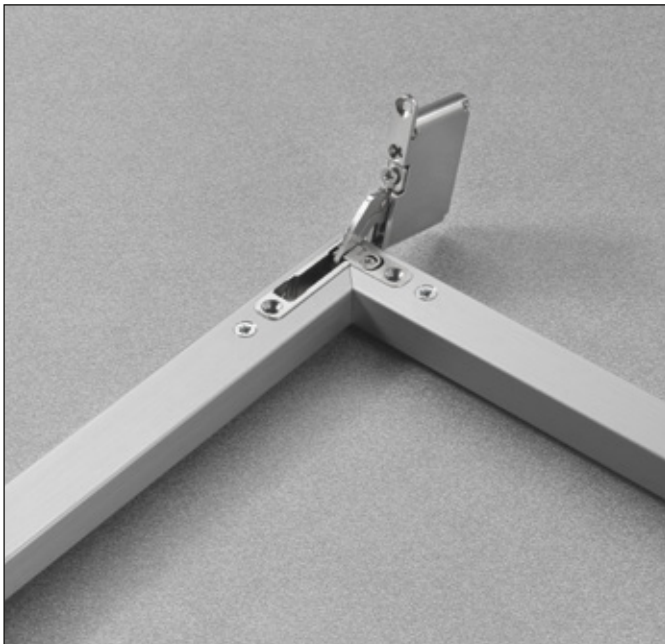
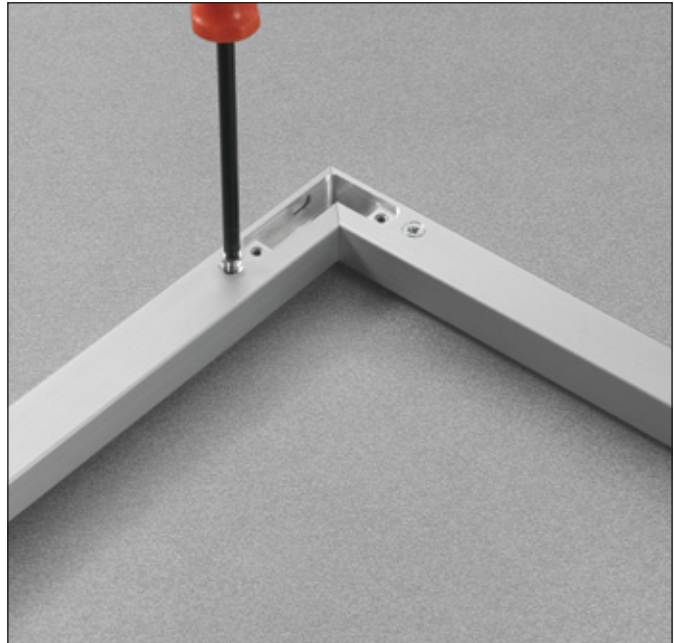
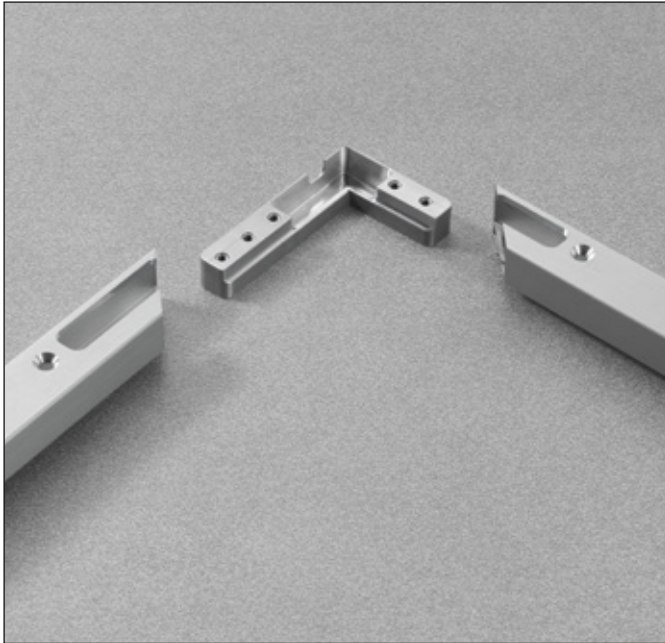

**CEL\_D** is marked **R**  
**CEL\_S** is marked **L**

For a left hand opening door, use a **CEL\_D** on the top and **CEL\_S** on the bottom.

For a right hand opening door, use a **CEL\_D** on the bottom and a **CEL\_S** on the top.

For aluminum frame doors: Where a **CEL\_D (R)** hinge is used, you must use a corner bracket marked **R**.

For aluminum frame doors: Where a **CEL\_S (L)** hinge is used, you must use a corner bracket marked **L**.



**Overlay specifications**

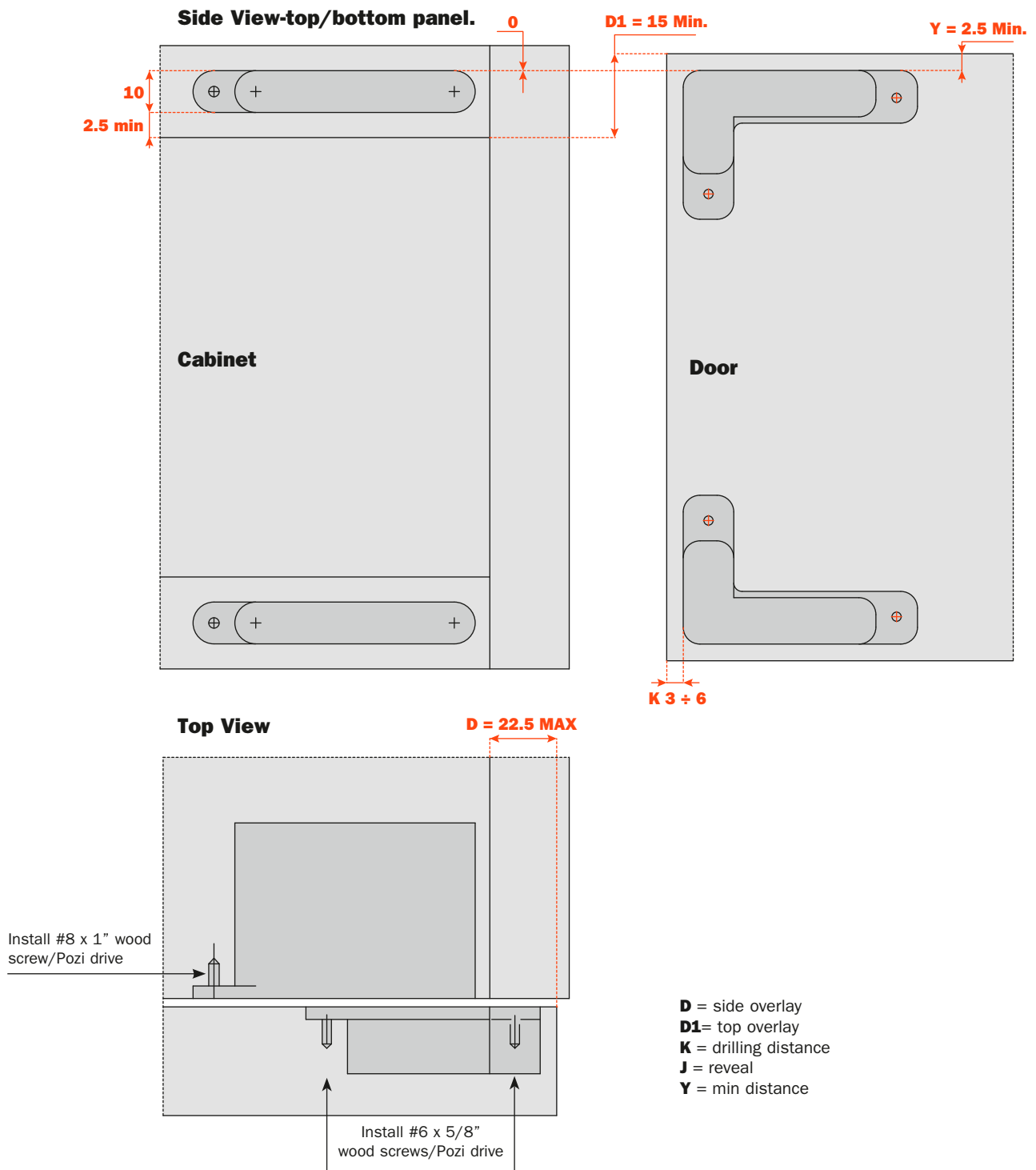

# Drilling specifications

## Top and bottom panel.

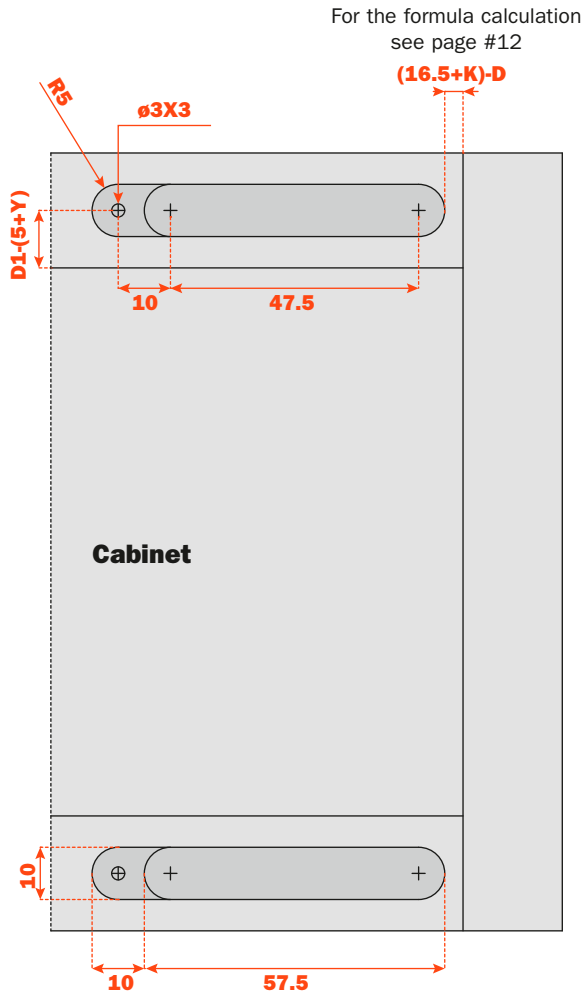

## Door drilling.

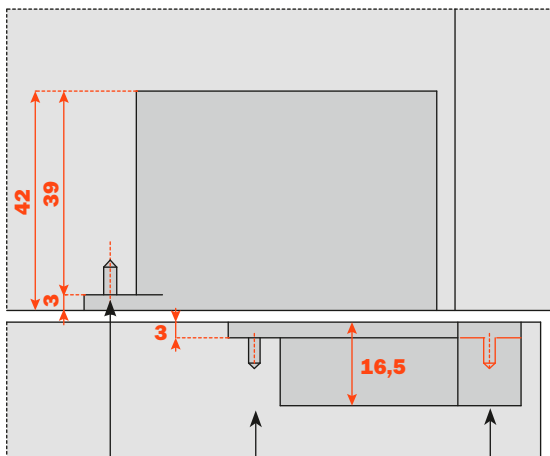
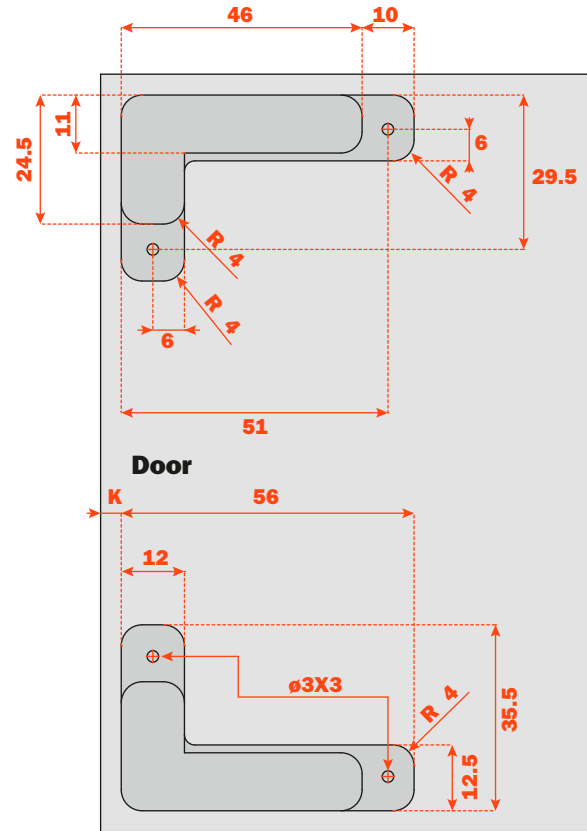

Install #8 x 1" wood screw/Pozi drive

Install #6 x 5/8" wood screws/Pozi drive

- D** = side overlay
- D1** = top overlay
- K** = drilling distance
- J** = reveal
- Y** = min distance

Note: Pre-drill holes with  $\varnothing 2$ mm drill bit.

**Overlay specifications**

Specs for the frame DEL6LP300\_ and use of the corner connectors DEL6BSFV02.

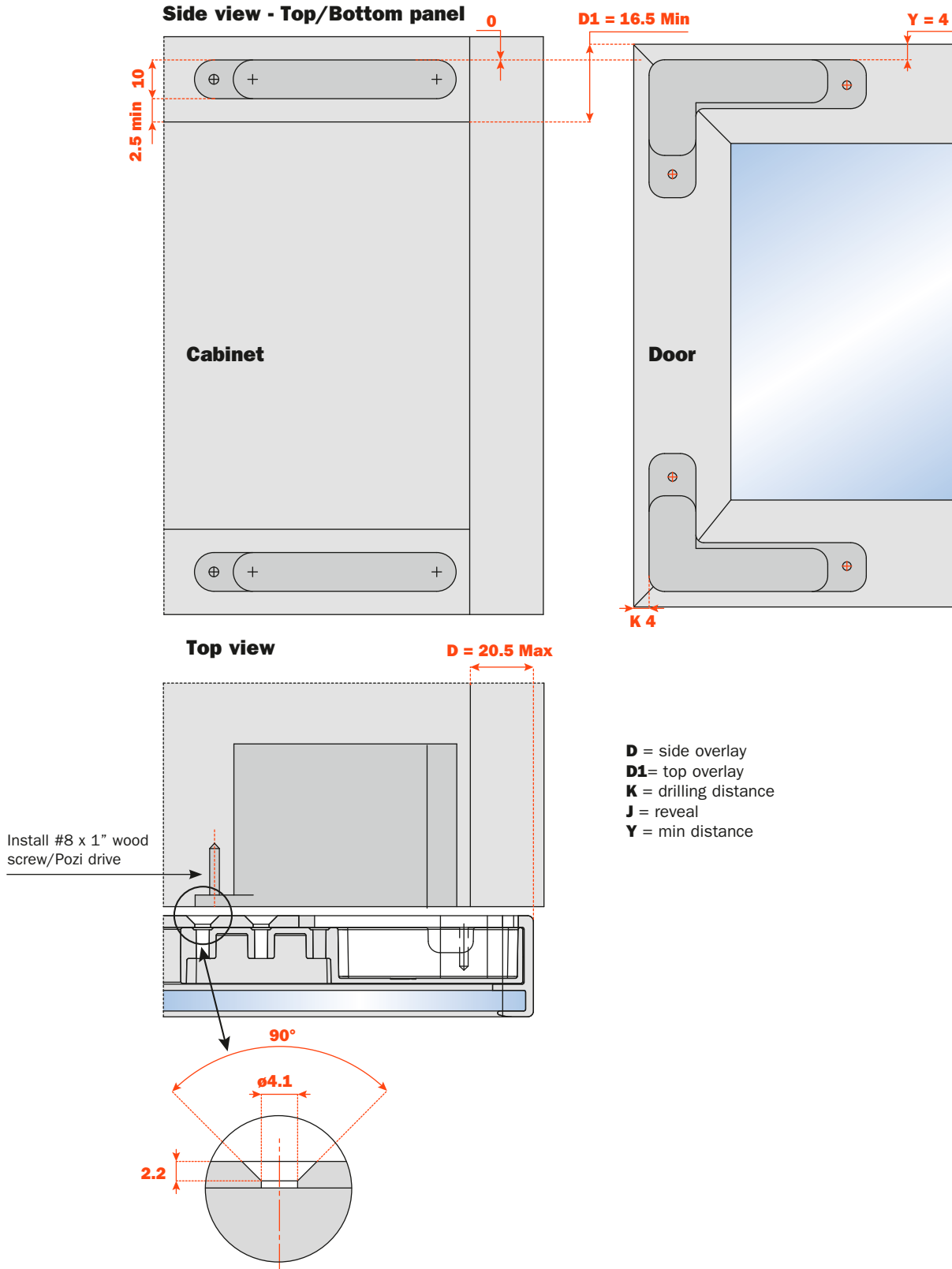



# Drilling specifications

## Top and bottom panel.

## Milling for aluminum frame doors.

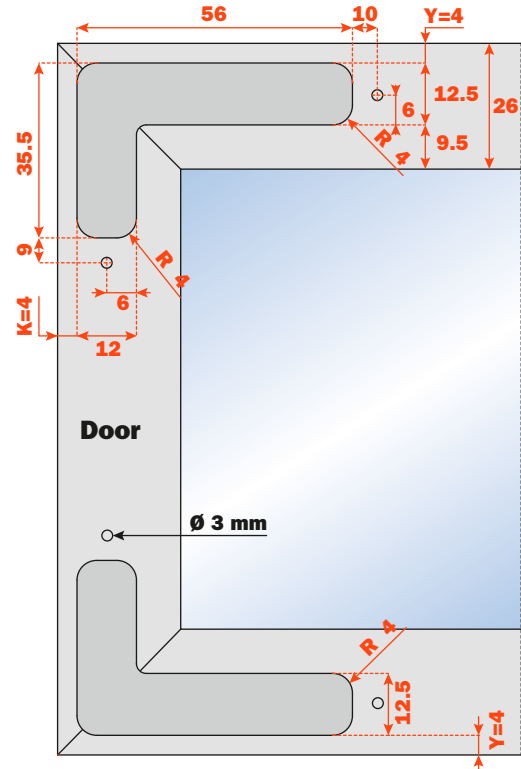
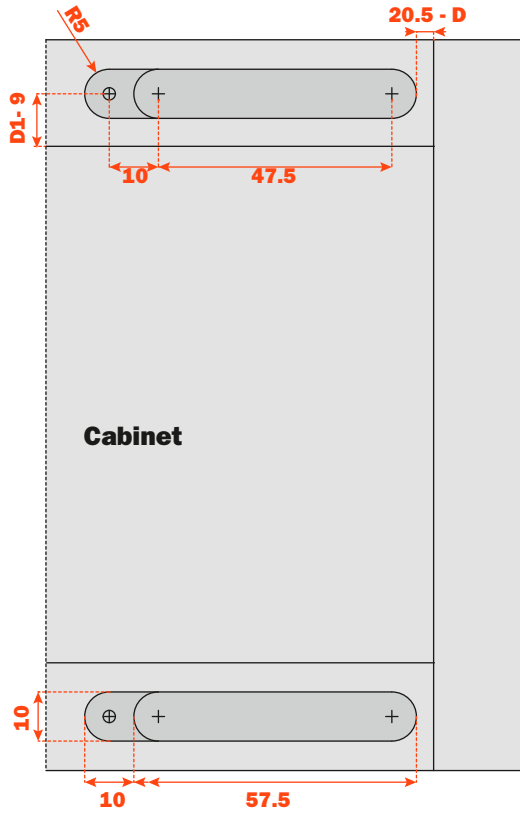

Install #8 x 1" wood screw/Pozi drive

Note: Pre-drill holes with  $\varnothing 2\text{mm}$  drill bit.

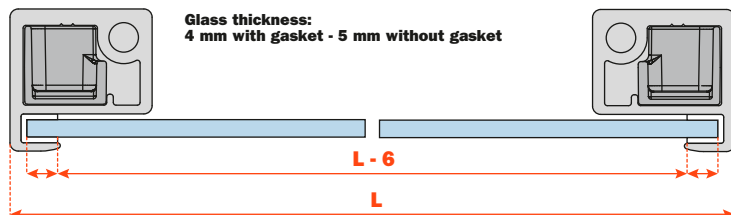
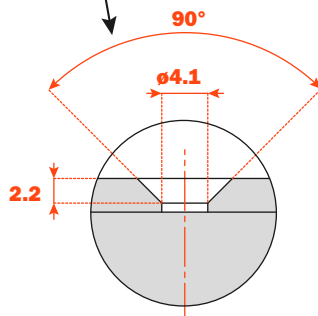
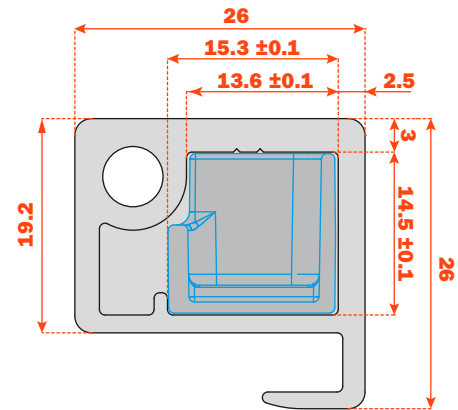
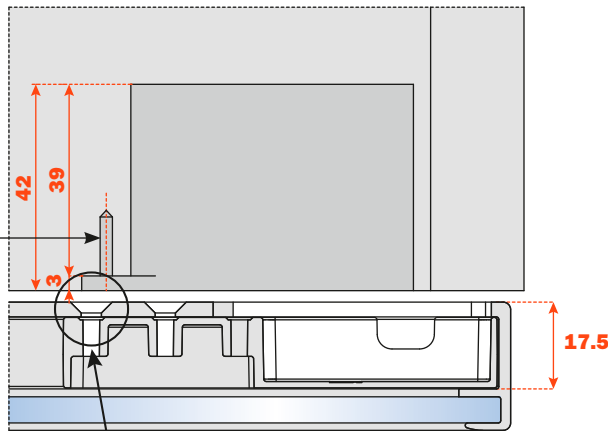

<b>K</b> = Drilling distance	<b>3</b>	<b>3.5</b>	<b>4</b>	<b>4.5</b>	<b>5</b>	<b>5.5</b>	<b>6</b>
<b>J</b> = Reveal							
<b>0</b>	19.5	20	20.5	21	21.5	22	22.5
<b>0.5</b>	19	19.5	20	20.5	21	21.5	22
<b>1</b>	18.5	19	19.5	20	20.5	21	21.5
<b>1.5</b>	18	18.5	19	19.5	20	20.5	21
<b>2</b>	17.5	18	18.5	19	19.5	20	20.5
<b>2.5</b>	17	17.5	18	18.5	19	19.5	20
<b>3</b>	16.5	16	17.5	17	18.5	19	19.5
<b>3.5</b>	16	16.5	17	17.5	18	18.5	19
<b>4</b>	15.5	16	16.5	17	17.5	18	18.5
<b>4.5</b>	15	15.5	16	16.5	17	17.5	18
<b>5</b>	14.5	15	15.5	16	16.5	17	17.5
<b>5.5</b>	14	14.5	15	15.5	16	16.5	17
<b>6</b>	13.5	14	14.5	15	15.5	16	16.5
<b>6.5</b>	13	13.5	14	14.5	15	15.5	16
<b>7</b>	12.5	13	14.5	14	14.5	15	15.5
<b>7.5</b>	12	12.5	13	13.5	14	14.5	15
<b>8</b>	11.5	12	12.5	13	13.5	14	14.5
<b>8.5</b>	11	11.5	12	12.5	13	13.5	14
<b>9</b>	10.5	11	11.5	12	12.5	13	13,5
	<b>OVERLAY</b>						

## Side adjustment range +2 to -2

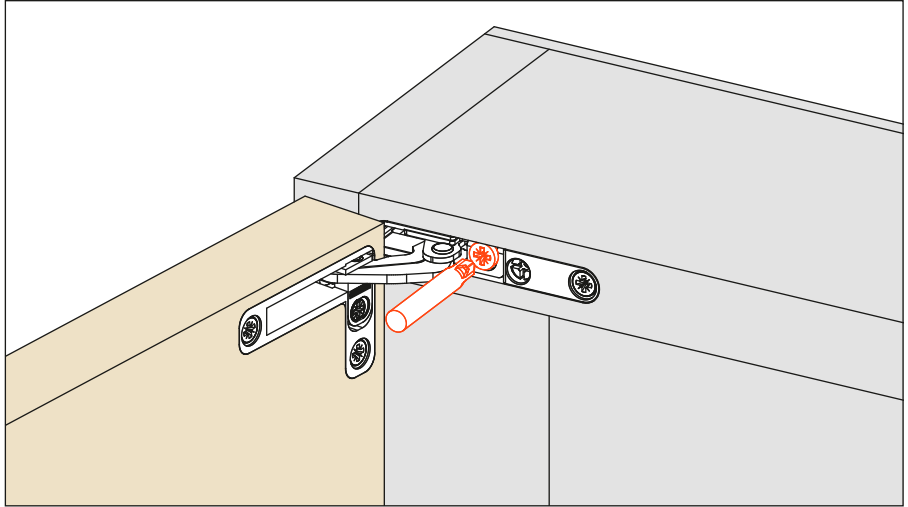
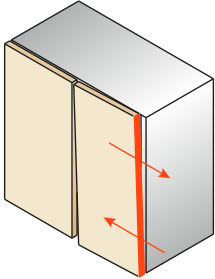

## Depth adjustment range +2 to -0.5

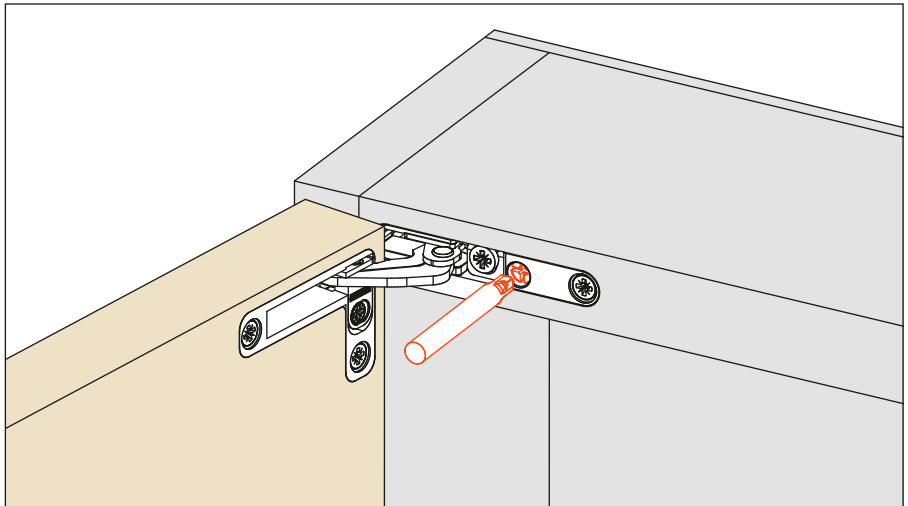
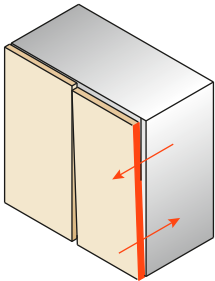

## Height adjustment range +1.5 to -1.5

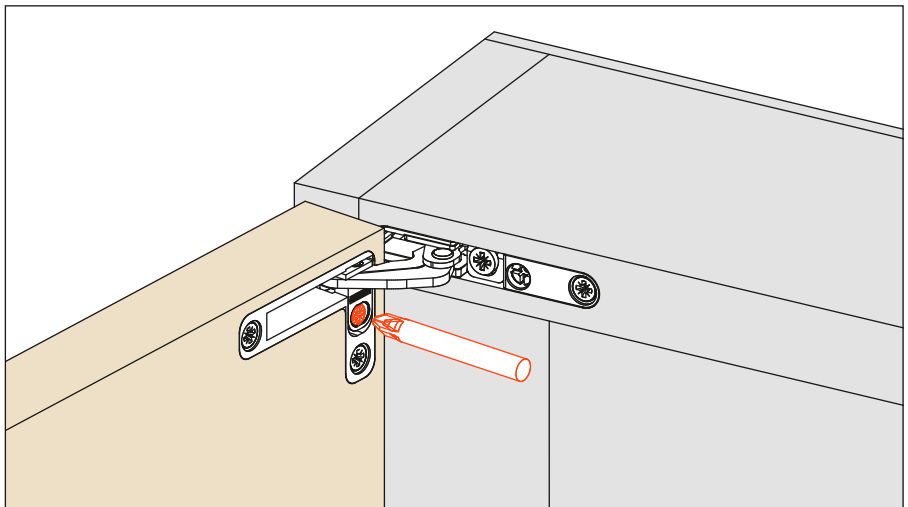
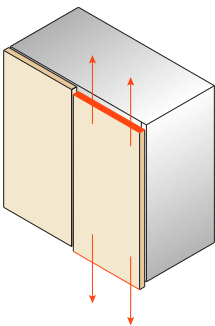

## Magnetic Push - Release device and retaining catches

**DPMSNB** - beige



**DPMSNG** - grey



Release device.  
ø 10 mm, 40 mm length.

**Packing**

Box 250 pieces  
Carton 1.500 pieces

**DPASNB** - beige



**DPASNG** - grey



Release device to be used to increase the magnetic holding strength. It must always be used together with the DPM. The suggested position of the DPM is the point of pressure on the door. The DPA can be positioned at any point along the opening edge of the door.  
ø 10 mm, 40 mm length.

**Packing**

Box 250 pieces  
Carton 1.500 pieces

**DP39XXG**

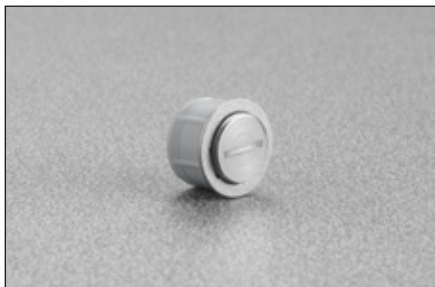

Adjustable magnetic catch.  
Inserted into the door.  
ø 15 mm

**Packing**

Box 250 pieces

**DP28SN9**



Retaining catch to be inserted with pin.  
ø 11.5 mm surface.

**Packing**

Box 250 pieces

**DP38XX91**



Retaining catch with adhesive.  
20x14 mm surface.

**Packing**

Box 250 pieces

## Release device application

### Release device to be inserted

Drill a hole  $\varnothing$  10 mm and min. 40 mm depth in the top, the side or the bottom panel of the cabinet.  
Insert the release device into the hole.

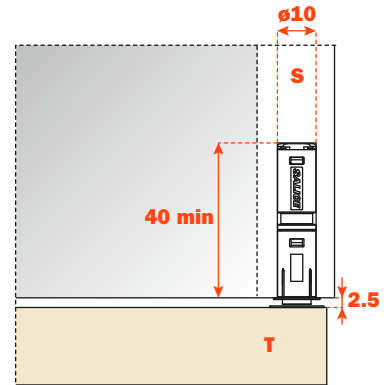

### Adjustable magnetic catch

The adjustable catch DP39 is itself magnetic and together with the magnetism of the release device DPM considerably increases the holding strength (30%) of the door against the cabinet side, thus avoiding accidental opening.

For the installation it is necessary to drill a hole  $\varnothing$ 15 mm and 11 mm depth in the door.

Depth adjustment from +2.5mm / - 0.5mm

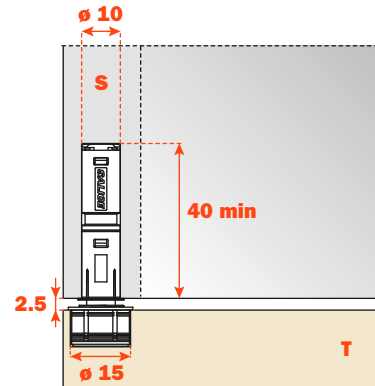

### Retaining catch to be inserted

Apply the retaining catch to the magnetic release device.  
Close the door.  
The point of the retaining catch will show where to insert it.  
Reopen the door and press the retaining catch.

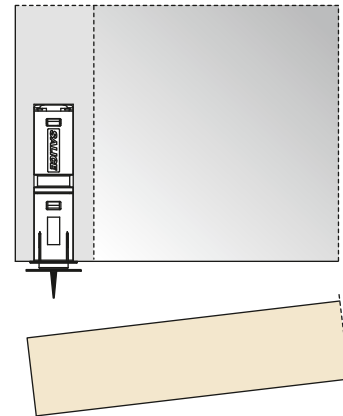

### Retaining catch with adhesive strip

Apply the retaining catch to the magnetic release device. Remove the protective strip from the adhesive. Close the door and the retaining catch is positioned on the door.  
Reopen the door and apply a firm pressure to the retaining catch to ensure a correct installation.

#### ATTENTION:

For a correct application and to ensure optimal endurance, we suggest these guidelines are followed:

- 1 - clean and degrease the door surface where the retaining catch is to be installed;
- 2 - remove the protective strip from the adhesive;
- 3 - place the retaining catch in position, in a place that is at room temperature  $\geq 10^\circ$  (50°F) and apply a firm pressure for 10-15 seconds.

After few seconds from the installation the retaining catch is suitable for the use.  
After 24h the max. hold is attained.

