

1. Remove the clamp head from one K Body clamp.

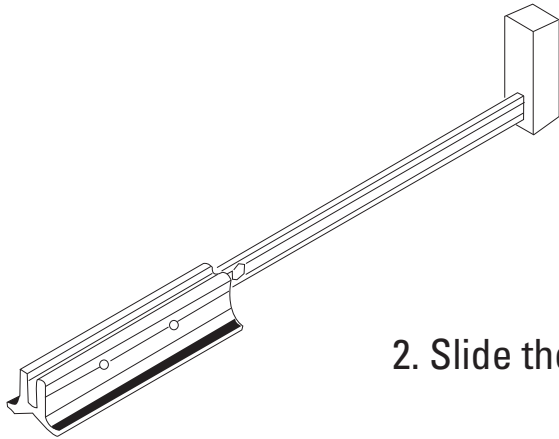

2. Slide the K Body Extender onto the clamp rail.

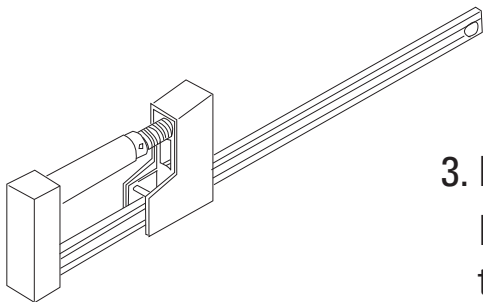

3. Reverse the clamping head on the second K Body clamp and slide it up the rail until the handle touches the clamp end.

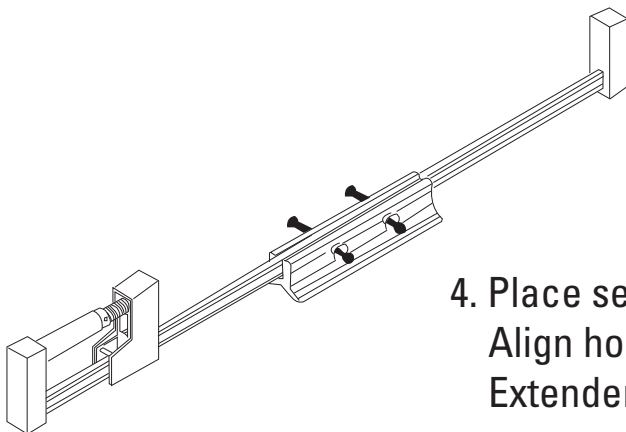

4. Place second clamp in the K Body Extender. Align holes in clamp rail with holes in K Body Extender. Screw in bolts and tighten.