

FR 771.ECD

SLIDE TYPE:	Progressive action full-extension pantry pull-out slide with top slide
MOUNTING:	Floor Mount

LOAD CAPACITY:	dynamic up to 125 kg (275 lbs.)
-----------------------	---------------------------------

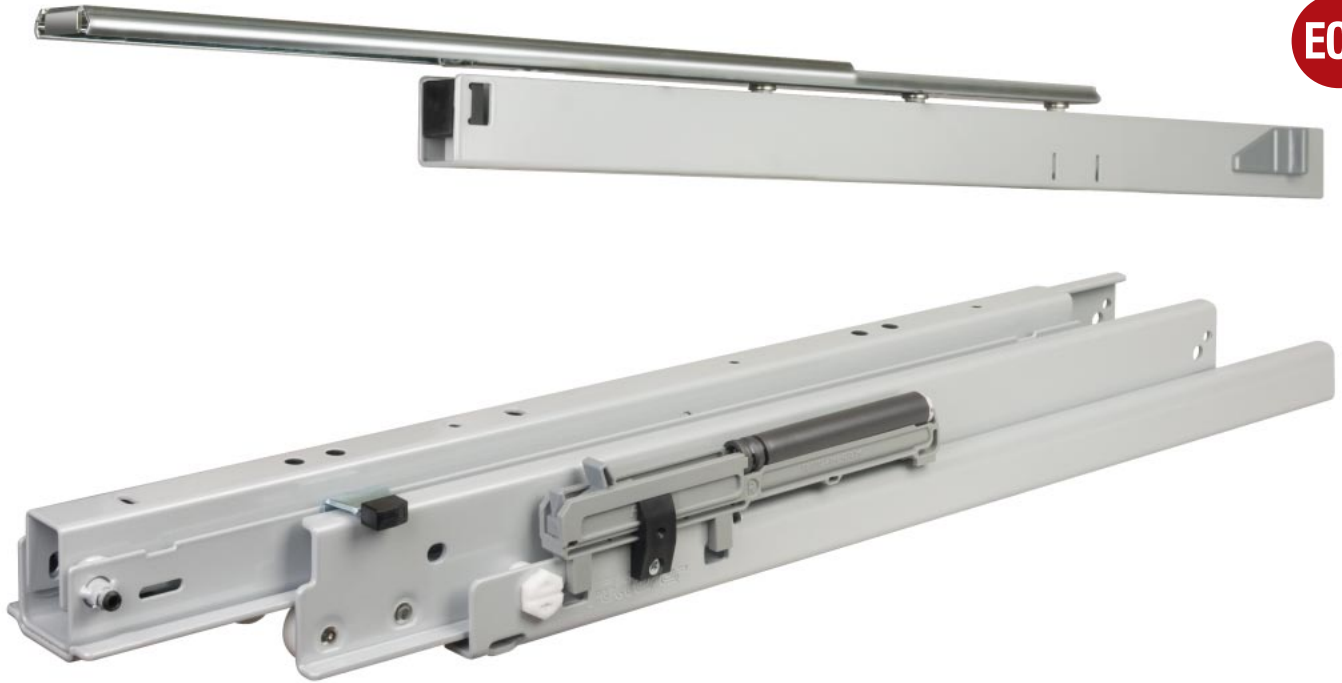

MATERIAL:	powder coated cold rolled steel
------------------	---------------------------------

FEATURES:	solid delrin* rollers, delrin*-encased steel ball bearings
------------------	---

SPECIFICATIONS:
<ul style="list-style-type: none"> ▶ no deflection in fully extended position ▶ quick and easy installation ▶ quiet movement, even under the heaviest loads ▶ horizontal and vertical adjustment ▶ top slide for absolute lateral stability ▶ LGA-tested according to DIN 4554 standard at 50,000 double cycles ▶ back stop ▶ Easy Close Device (ECD) integrated (top and bottom slide)

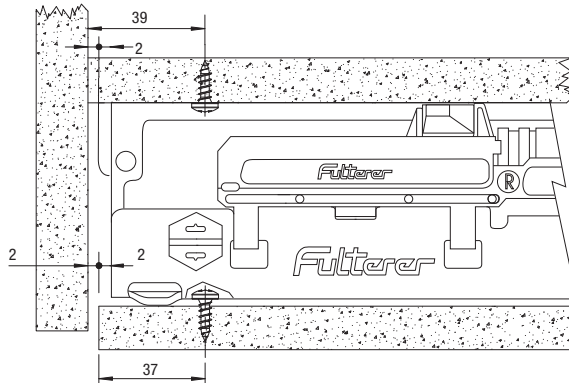
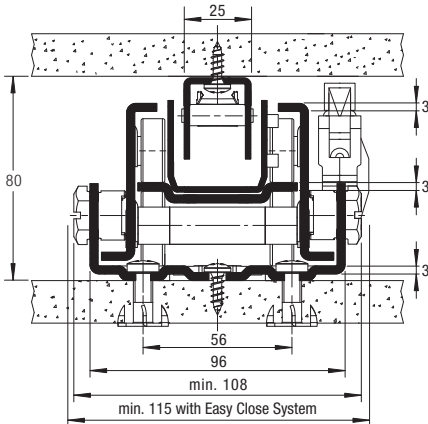
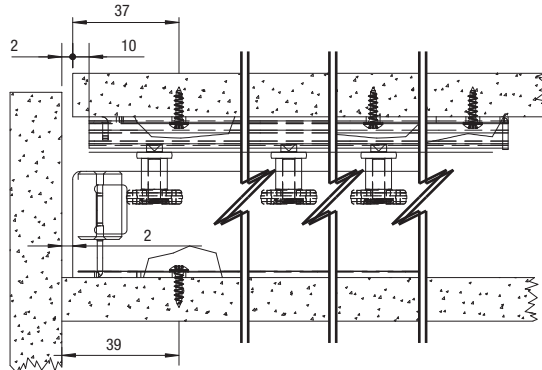
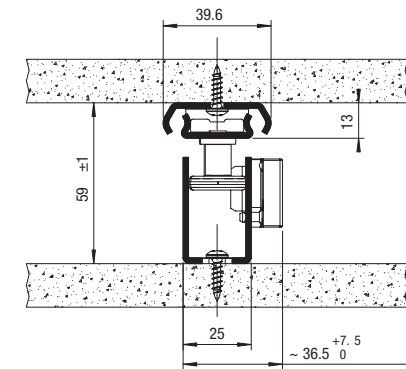

NOTE:
▶ Do not lubricate any part of the slide!

Length		Extension		Weight		Order No.
mm	in	mm	in	kg	lbs	silver
575	22.64	559	22.01	8.74	19.27	82042
Packing Unit: 1 set per box with instructions						

*DuPont (TM) Delrin®