

FOLDING BRACKET



EB



- Automatically locks when flap is in opened position.
- Press lever to release the lock.
- Bracket can be used without the need for hinges.
- Available in 3 different sizes.
- Only EB-303 is NSF certified.
- Damper unit EBD available for use with all EB series brackets. (Sold separately)

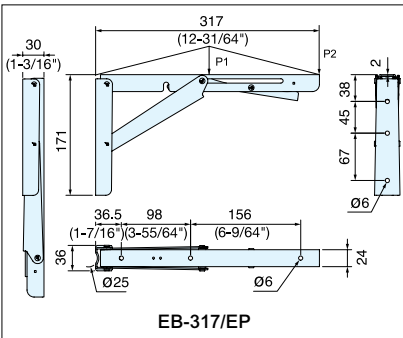
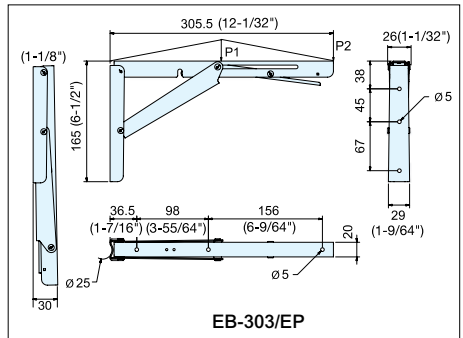
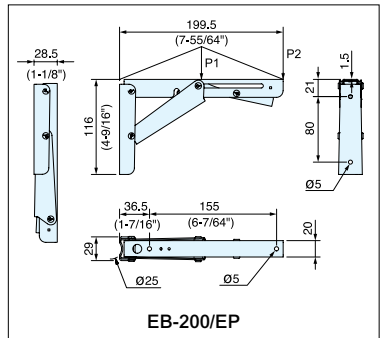
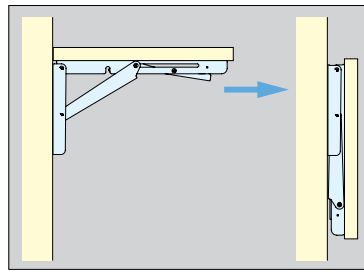
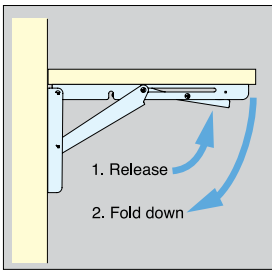

Item No.	Load Capacity P1 (kg)	Load Capacity P2 (kg)	Weight (g)	Carton (pcs)
EB-200/EP	175 (385 lbs)	90 (198 lbs)	330	50
EB-303/EP	150 (330 lbs)	75 (165 lbs)	515	25
EB-317/EP	200 (440 lbs)	100 (220 lbs)	750	50

Part Name	Material
Main Body	304 Stainless Steel
Plate Spring	
Rivet	