

PRODUCT DATA SHEET

Product Description: Passage lever, reversible, ANSI Grade 3. Fabricated from die cast zinc with a US15 satin nickel finish. Both levers are always free. Ships with mounting hardware. Lock ships with mortise latch. Optional drive in latch (product #87394) and UL10C fire rated latch (product #87373) available.

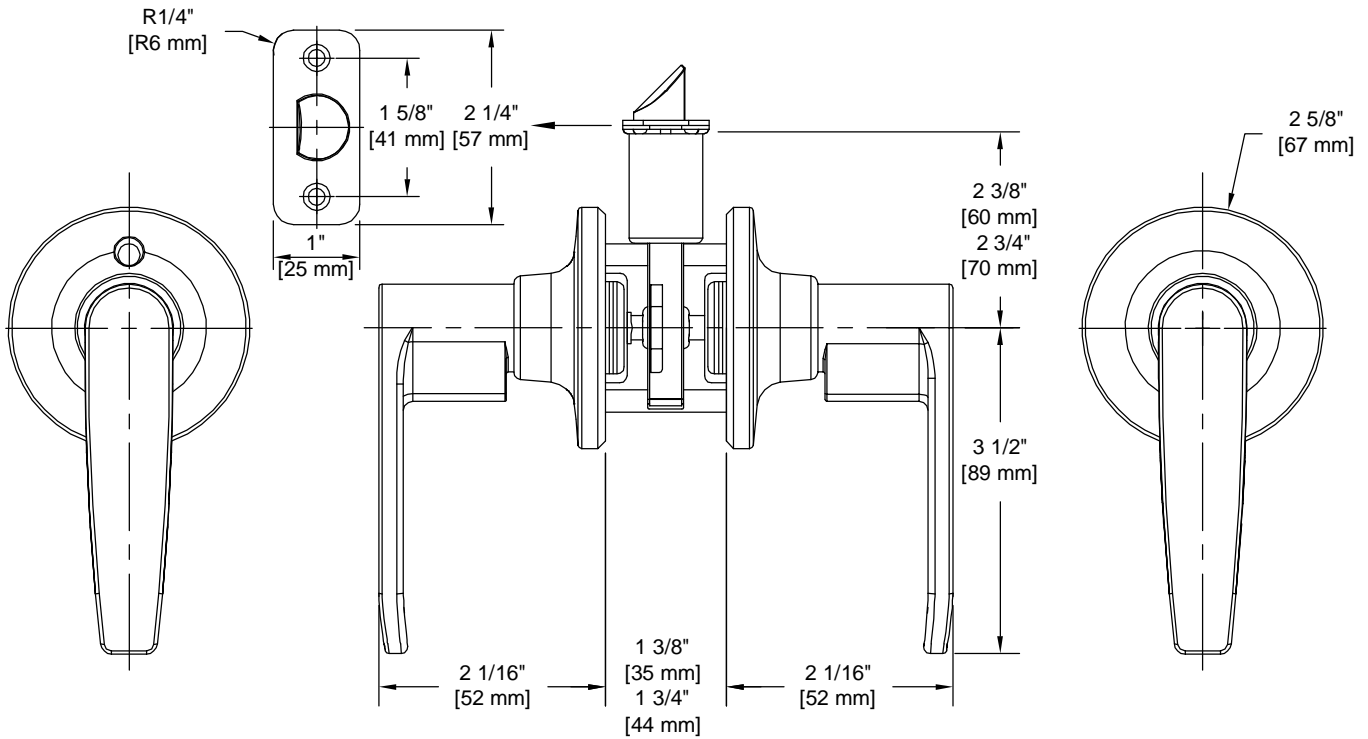

Door Prep: Cross Bore 2 1/8+, Edge Bore 1+, Mortise Latch Face 1+x 2 1/4+, Optional Drive In Latch 1" Diameter Drilled Hole
Latches: Ships With Mortise Latch As Shown Above. Optional Drive In Or UL10C Fire Rated Latches Available
Backset: Adjustable Latch to 2 3/8+or 2 3/4+
Door Thickness: Fit all 1 3/8+- 1 3/4+Standard Doors
Strike Plate: 2 1/4+Full Lip Strike
Bolt: 1/2+Throw



Overall Size: 4 13/16" W X 2 5/8" H X 2 1/16" D

Material: Die Cast Zinc

Finish: US15 Satin Nickel

Cross Reference

Manufacturer	Part Number



Description:

**Passage Lever, Reversible,
Electra, ANSI Grade 3**

Part Number:

86027

Date

09/16

Rev.

03

Sheet 1 of 1