

--- BBC-QS55 ---
(Quick Set-Up Batting Tunnel)
Installation Instructions

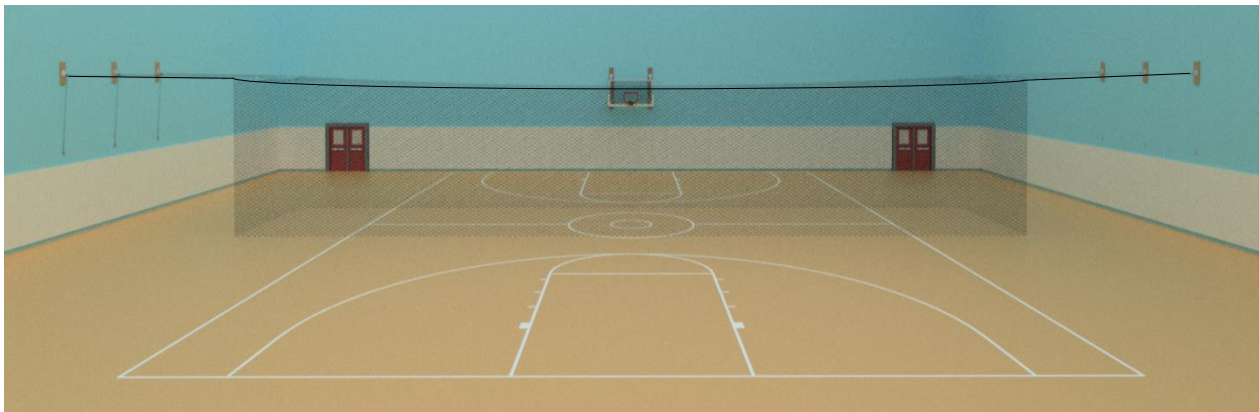

OPTIONAL WALL MOUNTING KIT
MODEL #: BBC-WLKT

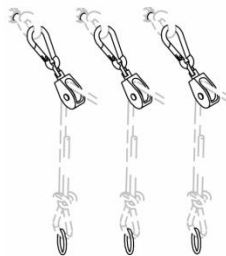

OPTIONAL WALL HOISTING KIT
MODEL #: BBC-QSKIT1

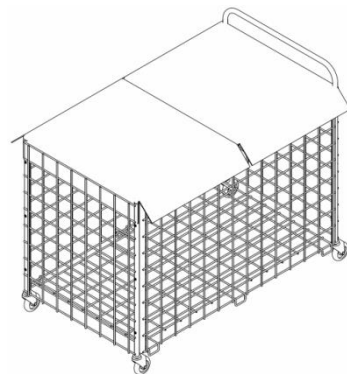

OPTIONAL NET STORAGE CART
MODEL #: TENINJA-CART

Call Jaypro Sports Equipment at 1-800-243-0533 during regular business hours for technical support.

www.jaypro.com

JAYPRO SPORTS
BBC-QS55, INDOOR QUICK SET-UP BATTING TUNNEL KIT

IMPORTANT NOTICE:

- 1) DO NOT SET CAGE OR NET TOO CLOSE TO WALLS, COLUMNS, LOW CEILINGS OR ANY SOLID OBJECT WHERE BALLS CAN STRIKE AND BOUND BACK. CAGE OR NET SHOULD BE AT LEAST **4 FEET FROM** ALL BYSTANDERS, CEILINGS, WALLS OR SOLID OBJECTS.
- 2) SPECTATORS MUST NOT STAND IN BACK OR NEAR SIDES OF CAGE OR NET WHILE BEING USED FOR BATTING PRACTICE.
- 3) ALTERATION OR MODIFICATION OF THIS EQUIPMENT MAY BE HAZARDOUS AND RESULT IN INJURY. FOR REPAIR OR REPLACEMENT, CONTACT YOUR DEALER OR JAYPRO SPORTS.
- 4) CAUTION: DO NOT OVER TIGHT THE CABLES, AS EXTREME LOADING WILL BE PLACED ON THE WALL OR END STRUCTURE.

PRODUCT DESCRIPTION:

The *BBC-QS55*, quick set-up batting tunnel kit is designed to attach to the walls of a gym. The distance between walls should not exceed 120 ft and must be a minimum of 63 ft. During set-up the net easily attaches to three (3) pre-installed polyester lines coming off of each wall. One wall will have three fixed length lines, while the other wall will contain the hoisting lines.

There are six wall attachments that need to be made, three on each wall. Because there are many different types of wall construction, additional wall anchors may be required depending on your type of building. Six (6) 3/8" eyebolts are provided for basic wall anchoring. These eyebolts can be directly installed in the metal building structure, existing wall blocking, or used in conjunction with double expansion anchors, in solid concrete walls.

If attaching to standard CMU block or stud constructed walls, it is recommended that a wood stringer wall mounting kit be used (model number *BBC-WLKT*), purchased separately. This kit includes six (6) attractive polyurethane finished 24" long, 2" x 8" stringers and mounting plates that are easy to install and help spread the load across multiple CMU blocks or other wall types. Studded walls will required that internal blocking be installed to help provide anchor points and spread the load across multiple studs.

An optional Supplemental Wall Hoisting Kit (*BBC-QSKIT1*) is available, that can provide added flexibility on the end of the tunnel opposite the main hoisting lines. The kit can be used if the anchor lines are too short to access from the floor, or to provide added tension if the hoist end is bottomed out.

ASSEMBLY INSTRUCTIONS

TOOLS REQUIRED:

- (1) Box Wrench Set
- (1) Electric Drill or Hammer Drill
- (1) Appropriate drill set (depends on wall construction)
- (1) Ladder or Scissor Lift
- (1) Tape measure

- Unpack all parts and check against parts list to ensure that all have been included.
- Inspect all parts for damage. Report any damages to the trucking company.

ITEM	DESCRIPTION	BBC-QS55
1	55' x 14' x 14' BBC NET (P/N: BBC-551414)	1
2	5/16" x 300 FT LONG BLACK BRAIDED ROPE	1
3	PULLEY BLOCK w/ CAM CLEAT (P/N: HM6568A)	3
4	SNAP HOOK (P/N: HM5013)	12
5	D-RING (P/N: HM240)	6
6	SWIVEL PULLEY (P/N: HM6226)	3
7	6" WIDE STEEL CLEAT (P/N: HM6331)	6
8	1/4"-20 x 2 3/4" HEX CAP SCREW	12
9	1/4" WASHER	12
10	1/4"-20 NYLON LOCK NUT	12
11	3/8"-16 x 3" EYEBOLT	6
12	3/8"-16 HEX NUT	6
13	3/8" LOCK WASHER	6
14	3/8" FLAT WASHER	12
		QTY

1) Mark the location of the cable anchor as shown in the diagram below.

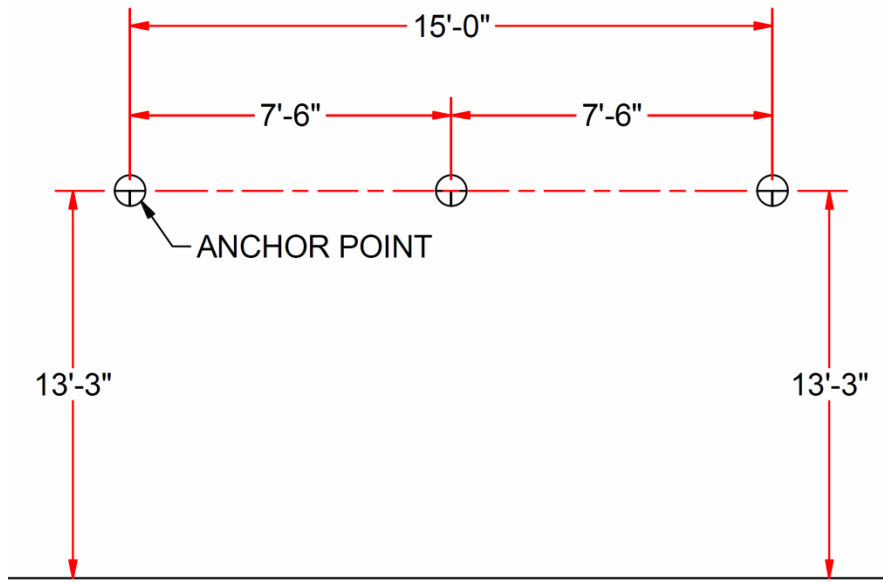

Anchor Point Locations on Building Wall (Both Ends)

Note: The height of the cables should be set at about 9” below the overall height of the net. This will place about 12” of net on the floor to capture the balls.

- 2) Install the wall anchors on both sides of the gym, as shown below. Follow the appropriate figure for your building type. Note: if optional wall mounting kit (BBC-WLKT) is purchased; please see installation instructions that come with it.

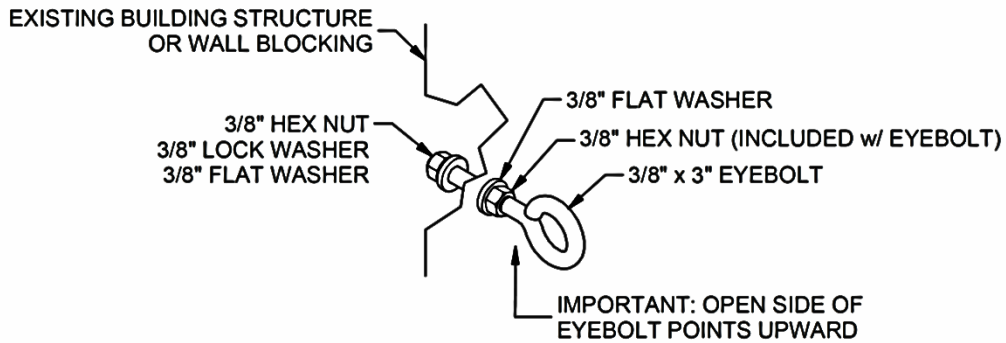

Figure 1: Standard Building Attachment - For Metal Structure and Wood Blocking

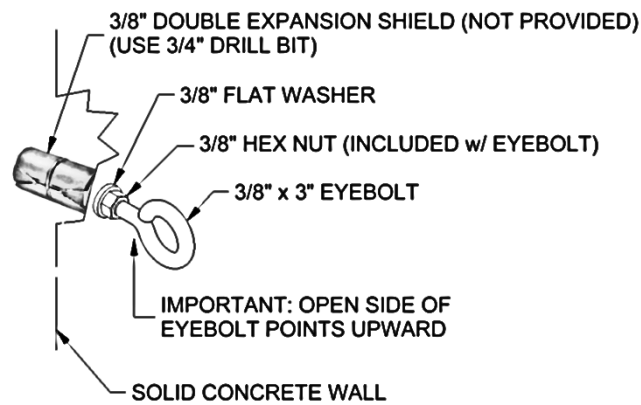

Figure 2: Standard Building Attachment - For Solid Concrete Walls
(Double Expansion Shield Anchors Not Provided)

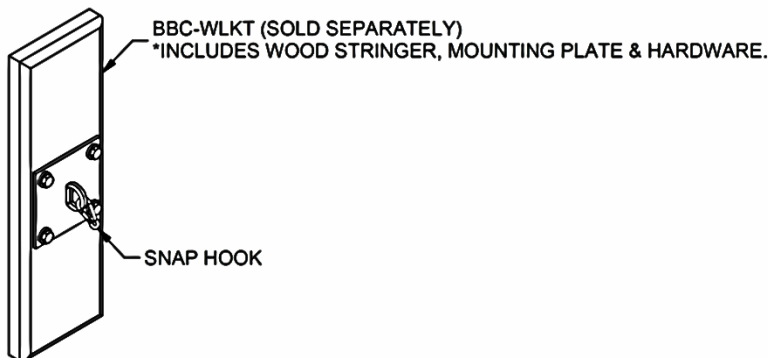

Figure 3: Optional Wall Mounting Kit – For CMU and Studded Walls
(Alternate Wall Anchors Required)

- 3) Make up and install the three fixed end lines. Based on the desired distance off the wall, cut three equal lengths of 5/16" black braided rope and tie two snap hooks to each end. Attach the three lines to the wall anchors.

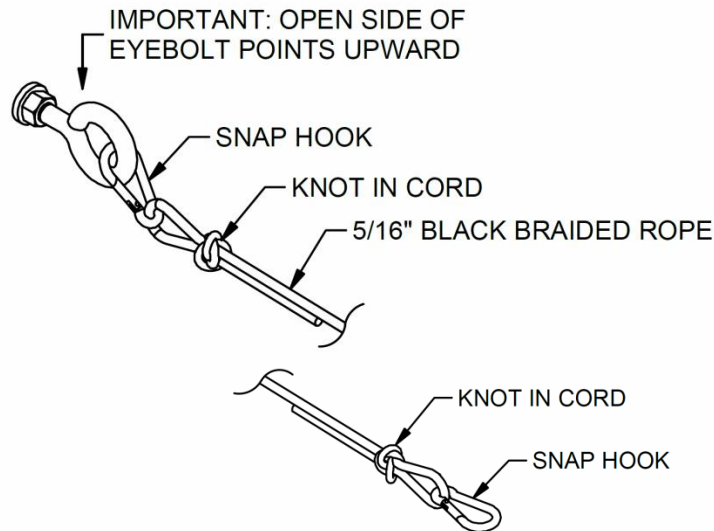

Figure 4: Fixed End Support Lines
(Line Length Base on Desired Distance off the Wall)

- 4) Make up and install the three hoisting lines. The approximate length of each line will equal twice the distance off the wall, plus 25 ft. Tie one end of the rope to the bottom of the pulley block and then pass it through the swivel pulley. Next pass the rope through the pulley block and cam cleat, as shown in Figure 5. Attach the three hoisting lines to the wall anchors.

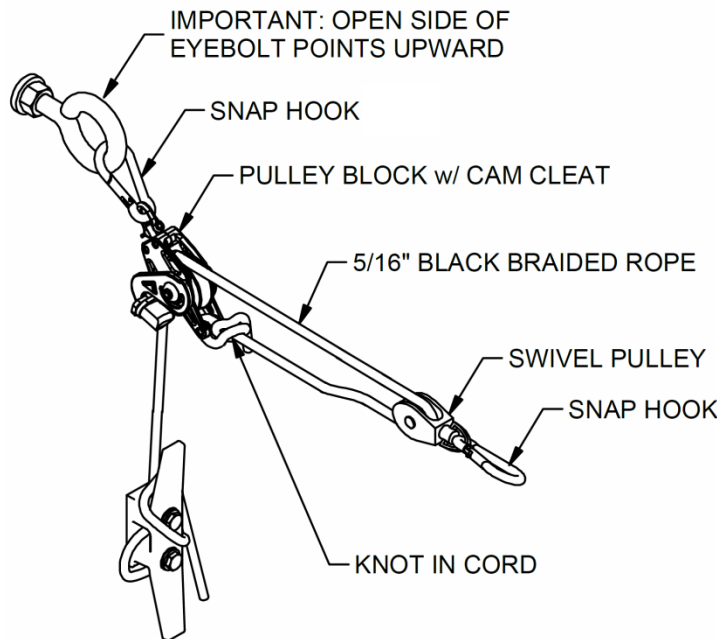

Figure 5: Hoisting Lines
(The Approximate Line Length Will Equal Twice The Distance Off The Wall, Plus 25 ft)

5) Make up the six leads on the end of the net as shown in Figure 6.

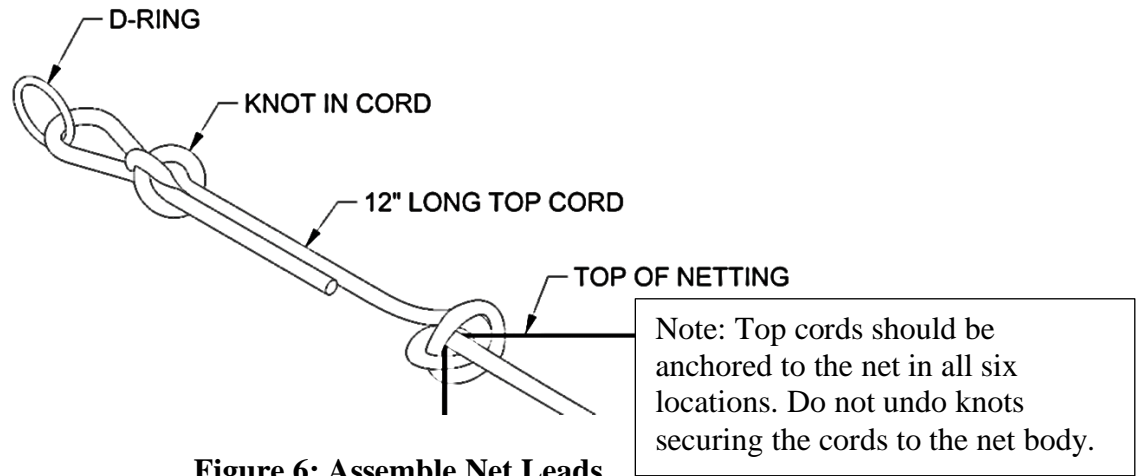

Figure 6: Assemble Net Leads
(6 Places on Netting)

6) Attach one end of the net to the fixed end lines. Feed out the three hoisting lines and attach each to the other end of the net. Evenly hoist the net up into position, making sure to apply equal tension to all three lines.

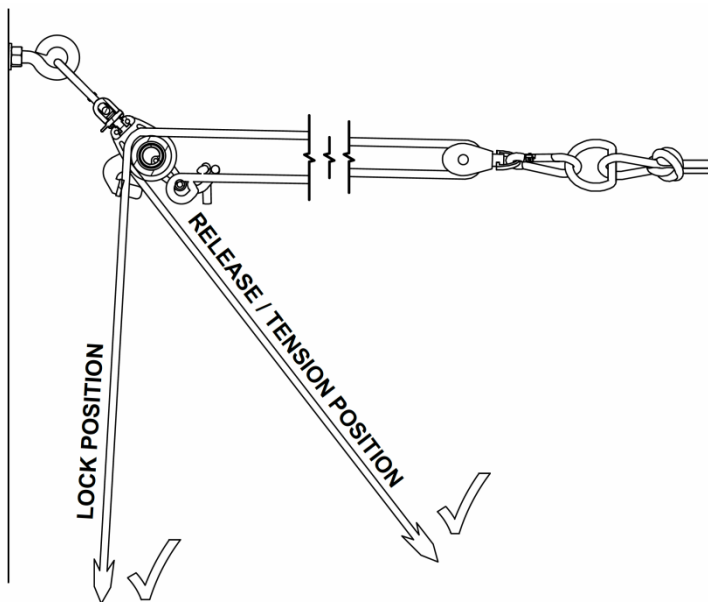
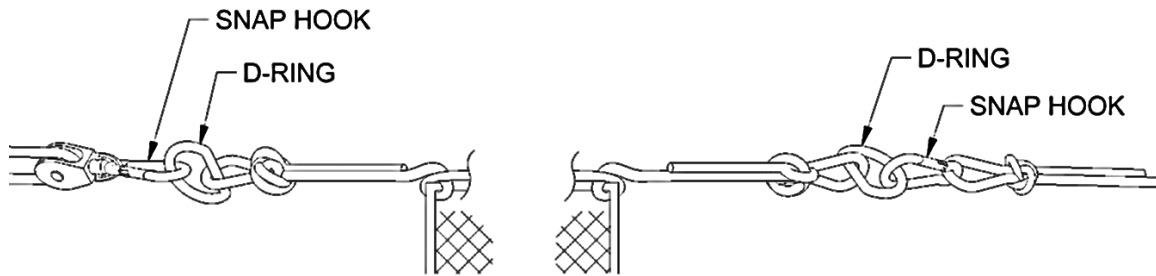

Figure 7: Assemble Suspended Net Leads

- 7) Make any necessary adjustments.
- 8) Install the Six, 6" wide steel cleats beneath each of the six lines, see Figure 8 & 9. It is recommended that the cleats be installed at a height of at least 7 ft above the floor.

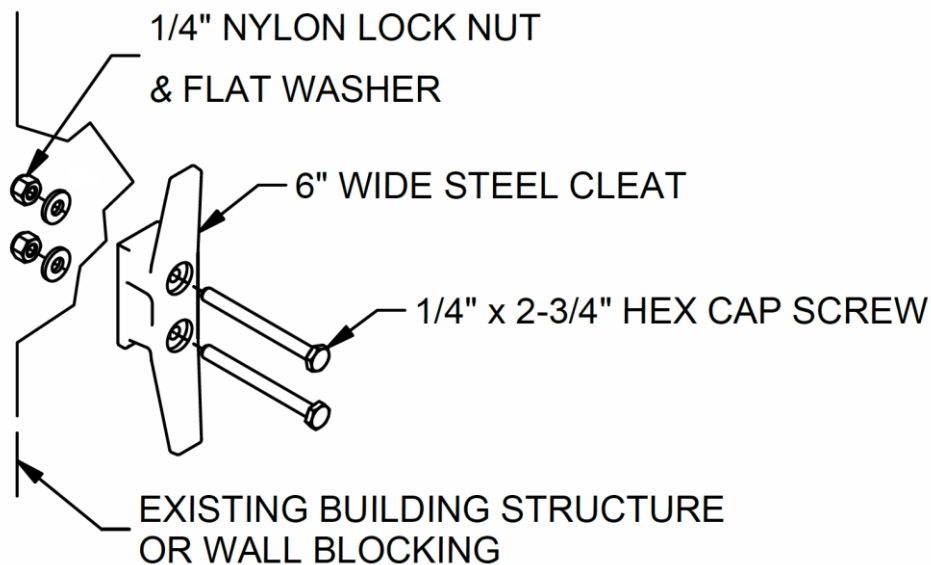

Figure 8: Standard Building Attachment - For Metal Structure and Wood Blocking

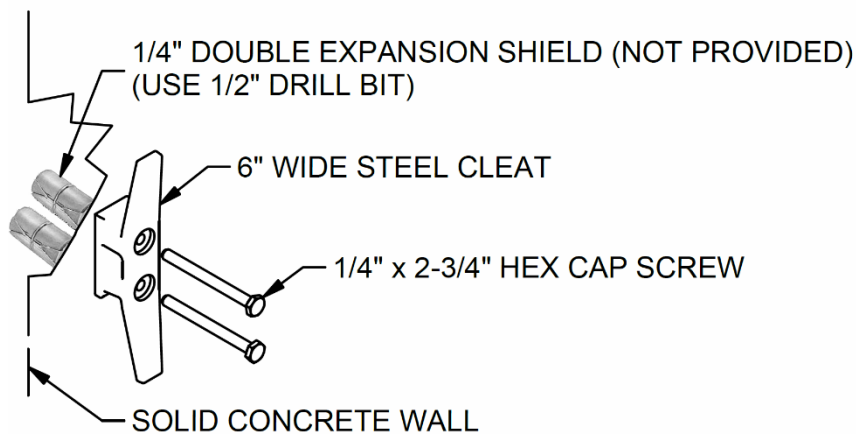
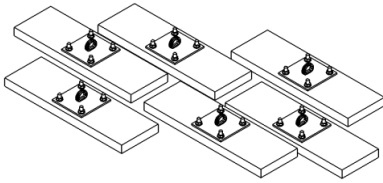

Figure 9: Standard Building Attachment on Fixed End - For Solid Concrete Walls
(Double Expansion Shield Not Provided)

- 9) Lower the net by releasing each hoisting line from the cam cleat. Before removing the net go back and cut off any excess rope from the hoisting line. Tie a knot in the very end of each line to prevent the line from accidentally passing through the pulley block.
- 10) Remove the net and store in a suitable container. See optional net storage cart (TENINJA-CART).
- 11) Gather all lines and hang them from their respective wall cleat.

OPTIONAL KITS AND HARDWARE:



MODEL #: BBC-WLKT
WALL MOUNTING KIT: (QTY: 6) Wood stringers and mounting plates for attaching to CMU block and concrete walls.

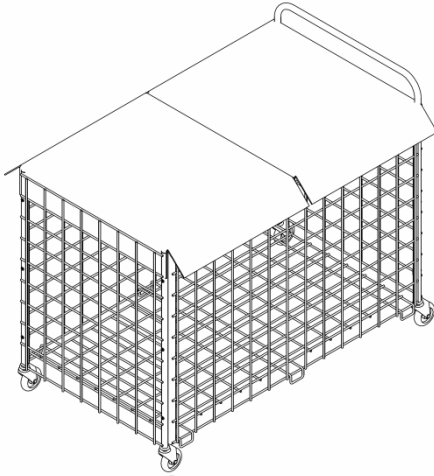

MODEL #: TENINJA-CART: Net storage cart.

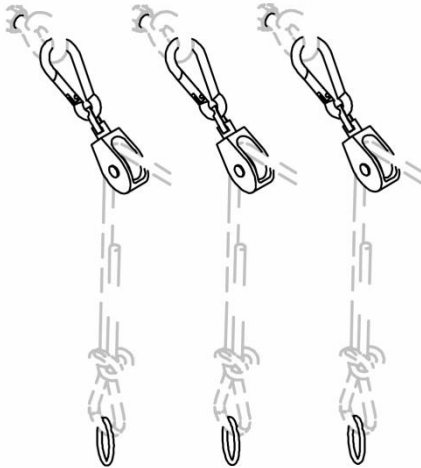

MODEL #: BBC-QSKIT1
Supplemental Wall Hoisting Kit
To be used if the anchor lines are too short to access from the floor, or to provide added tension if the hoist end is bottomed out.