

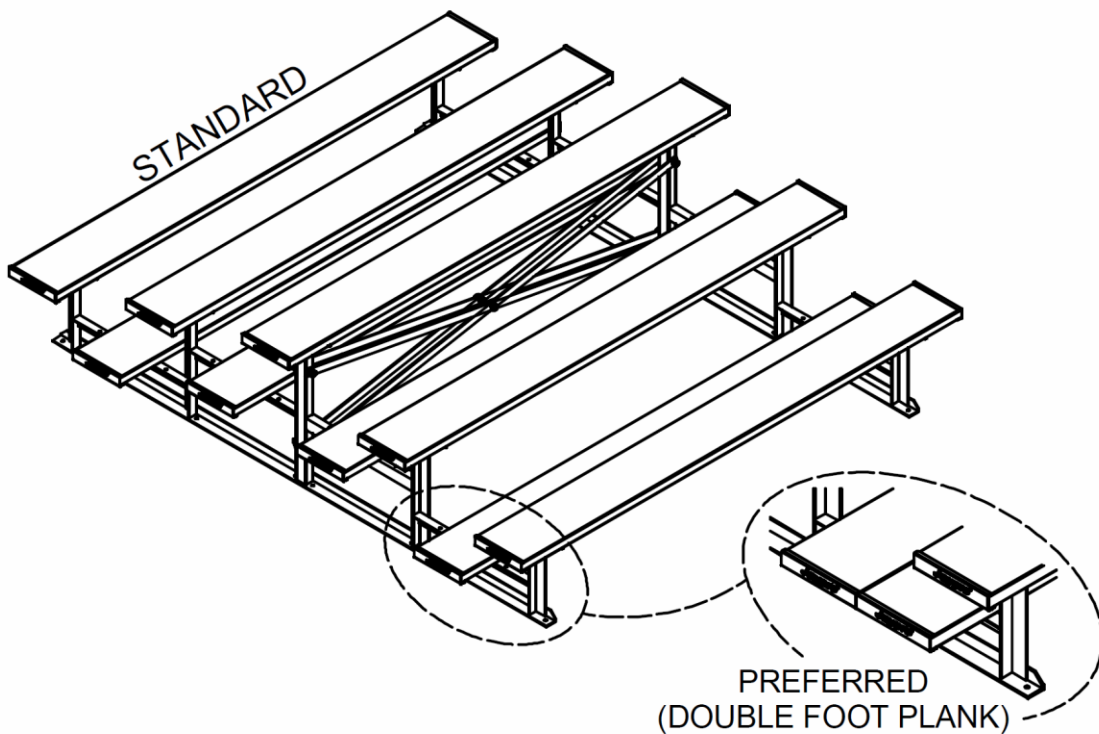

-- 3 ROW, 7 ½ FT BLEACHER --
(STANDARD & PREFERRED BACK TO BACK)
Installation Instructions

BTBB-375 → Standard Aluminum 3 Row, 7 ½ Ft Bleacher.

BTDP-375 → Preferred 3 Row, 7 ½ Ft Bleacher, w/ Double Planks.



Call Jaypro Sports Equipment at 1-800-243-0533 during regular business hours for technical support.

www.jaypro.com

JAYPRO SPORTS

3 ROW, 7 ½ FT ALUMINUM BACK TO BACK BLEACHER PARTS LIST

ITEM	PART #	DESCRIPTION	BTBB-375	BTDP-375	
1	BTBB-3RL	ALUMINUM 3-ROW BLEACHER LEG BACK 2 BACK	2	2	
2	BLAL-3RX-1	1/4" x 1 1/4" FLAT X-BARS	4	4	
3	AR5046	9 1/2" x 1 1/2" X 7'-6" STADIUM PLANK	9	13	
4	HN5038	1/2"-13 FLANGE NUT	6	6	
5	HB5054	5/16"-18 x 1 1/4" CARRIAGE BOLT, ZP	36	52	
6	HN5046	5/16"-18 FLANGE NUT, ZP	36	52	
7	AR5044	5/16" BOLT CLIP	36	52	
8	HS5035	#8 x 1/2" PAN HEAD PHILIP SCREW SELF DRILL, ZP	36	52	
9	AR5045A	9 1/2" ALUMINUM SEAT PLANK END CAP	18	26	
10	HW2044	1/2 SAE WASHER-ZP-GrNC	6	6	
11	HS2884	1/2-13 x 1-1/2 HEX CAP SCREW-ZP-GrNC	2	2	
12	HS2129	1/2-13 x 3-1/2 HEX CAP SCREW-ZP-GrNC	4	4	
			Kit # →	BTBB-375RK	BTDP-375RK
			Box # →	1	1

IMPORTANT NOTICE:

- 1) BEFORE EACH USE CHECK EQUIPMENT FOR PROPER CONNECTING HARDWARE AND STRUCTURAL INTEGRITY. REPLACE DAMAGED OR MISSING HARDWARE IMMEDIATELY.
- 2) USE OF THIS EQUIPMENT OTHER THAN INTENDED, MAY BE HAZARDOUS.
- 3) ALTERATION OR MODIFICATION OF THIS EQUIPMENT MAY BE HAZARDOUS AND RESULT IN INJURY. FOR REPAIR OR REPLACEMENT, CONTACT YOUR DEALER OR JAYPRO SPORTS.

ASSEMBLY INSTRUCTIONS

TOOLS REQUIRED:

- (1) 9/16" Socket Wrench and Box Wrench
- (1) 3/4" Socket Wrench and Box Wrench
- (1) Rubber Mallet
- (1) Phillips head screwdriver

- Unpack all parts and check against parts list to ensure that all have been included.
- Inspect all parts for damage. Report any damages to the trucking company.

Install Optional Bumper Feet & End Braces:

(Contact customer support for bumper feet – P/N: BLCHICK34)

1. Attach five rubber feet (bumpers) on the bottom of each leg as shown in figure 1.
 2. Install four end support X-Bar hardware on the backside of frame as shown in figure 2 – repeat this step to make another one, see figure 3.
- Note: Ensure that all leg frames angles are orientated in the same direction.

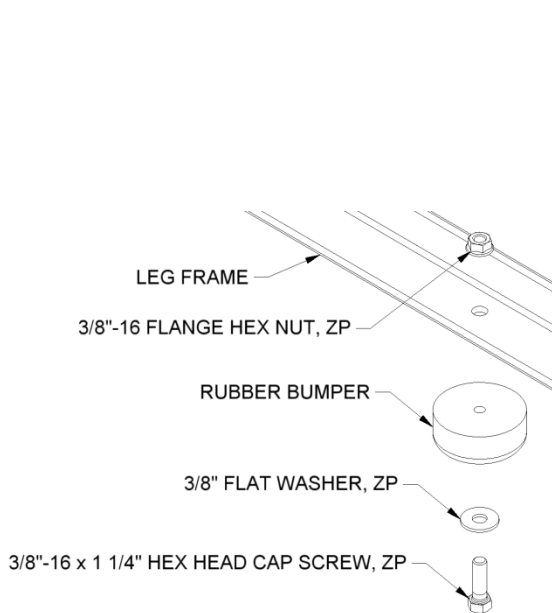

FIGURE: 1

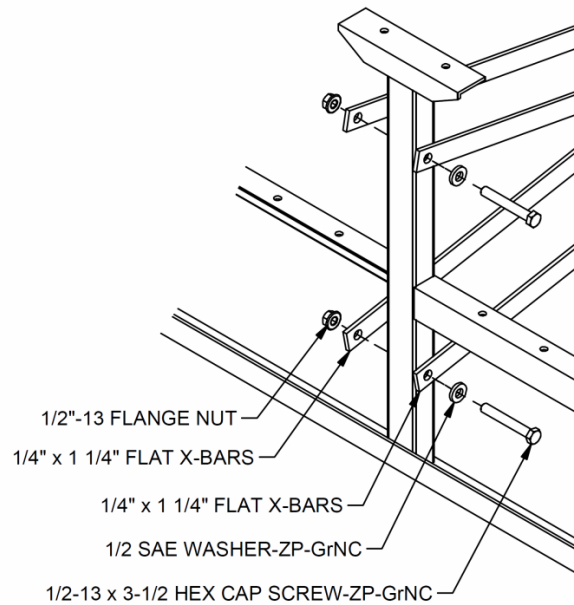

FIGURE: 2

Assemble Frame:

3. Assemble undercarriage frame as shown in figure 3. Vertically plumb and square each leg before tightening cross-bracing hardware.

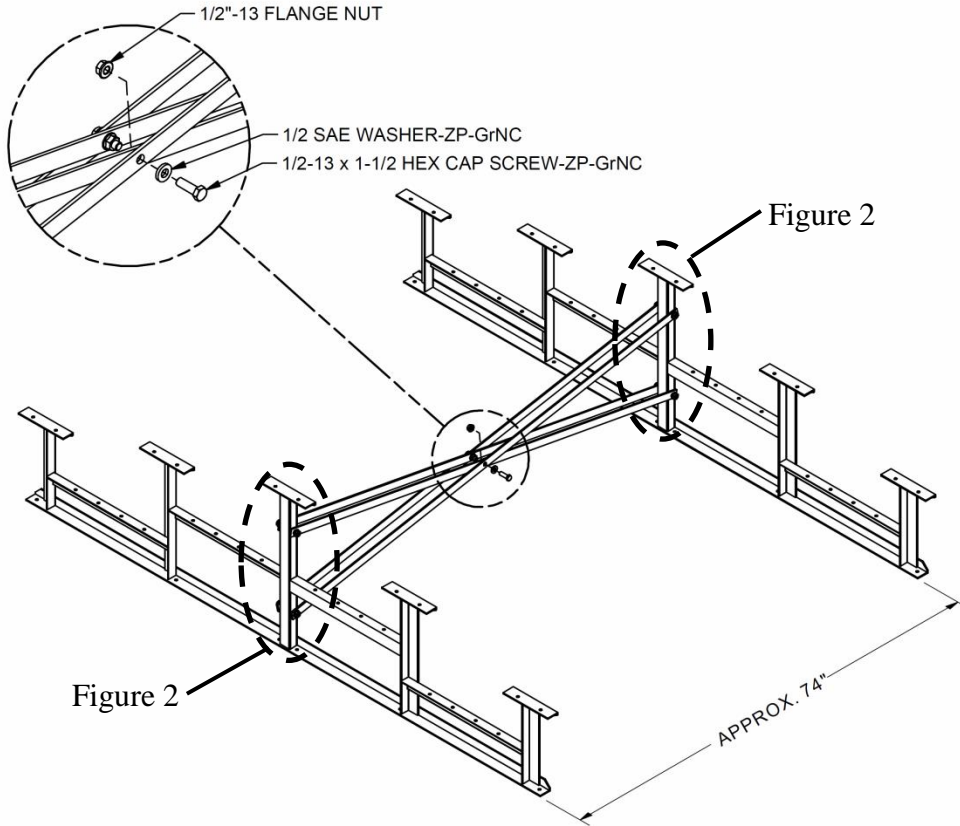

FIGURE: 3

Install Seat and Foot Planks:

4. Install end caps on both ends of each plank as shown in figure 4 – lightly tap on with a rubber mallet if necessary. Secure end caps in place using the #8 pan head self-drilling screws.

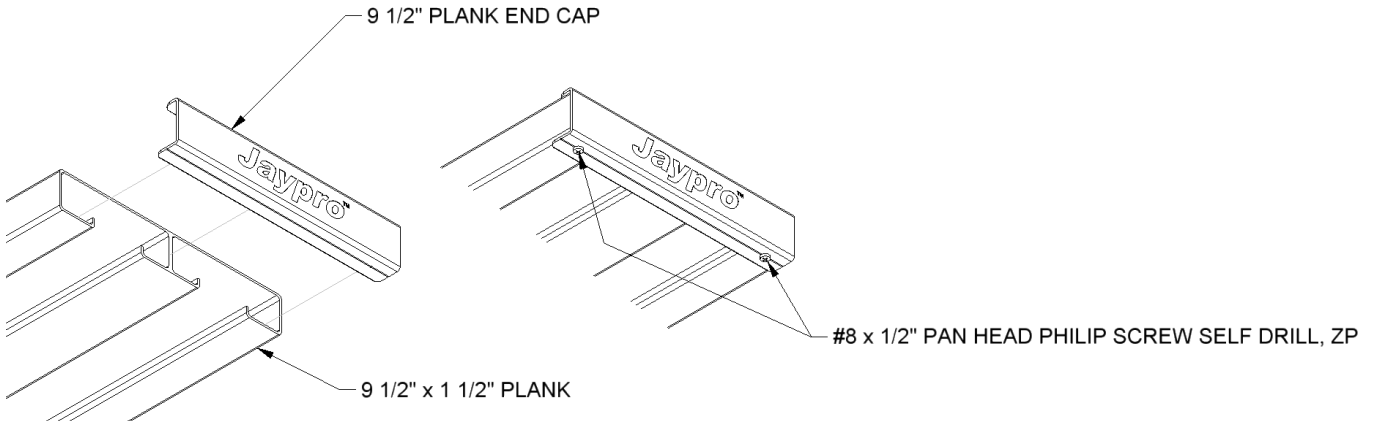

FIGURE: 4

Making sure the undercarriage frame is square and plumb, install the seat and foot planks.

The seat and foot planks are best installed starting from the front seat and working towards the back. Use the hardware and bolt clip as shown in figure 5. Position planks so they are centered on the frame, with equal amount of overhang on each end. Note that standard bleacher (BTBB-375) have a single foot plank, which is centered on the support frame, see figure 6. Preferred bleacher (BTDP-375) have double foot planks and are installed as shown in figure 7.

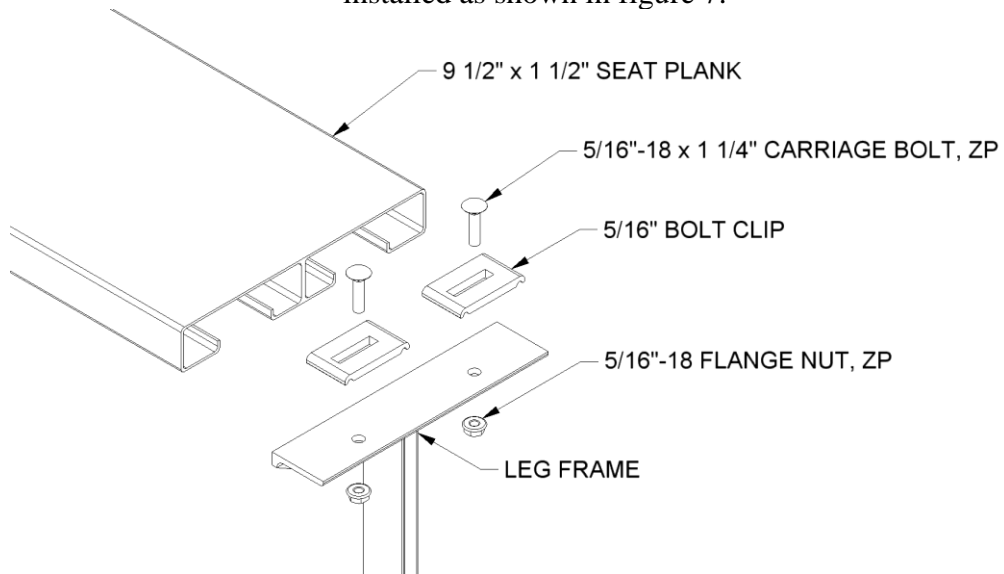

FIGURE: 5

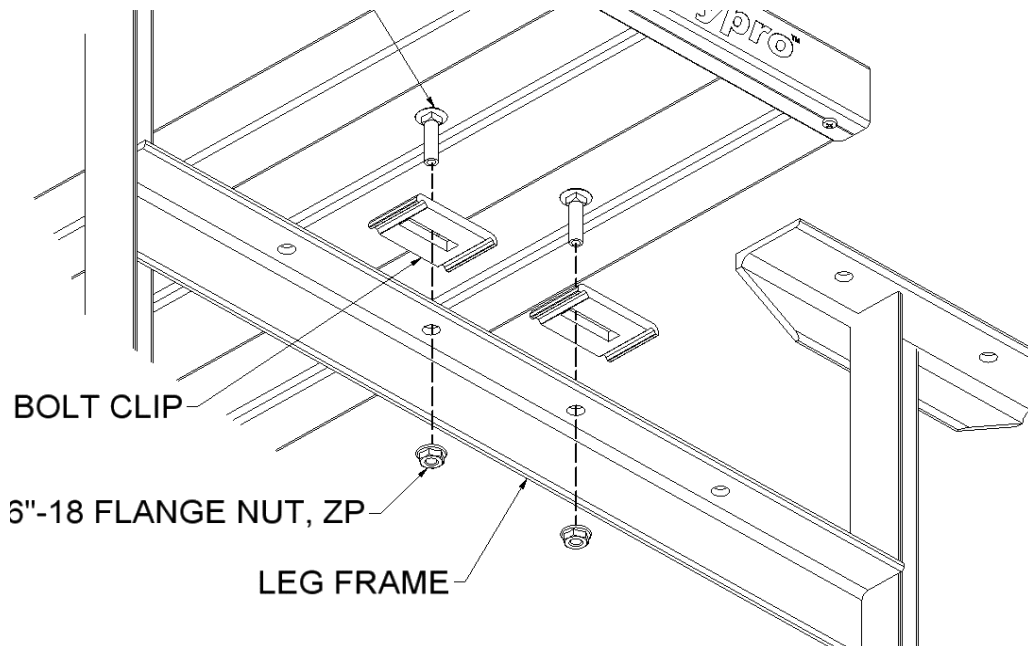

FIGURE: 6
(SINGLE FOOT PLANK)

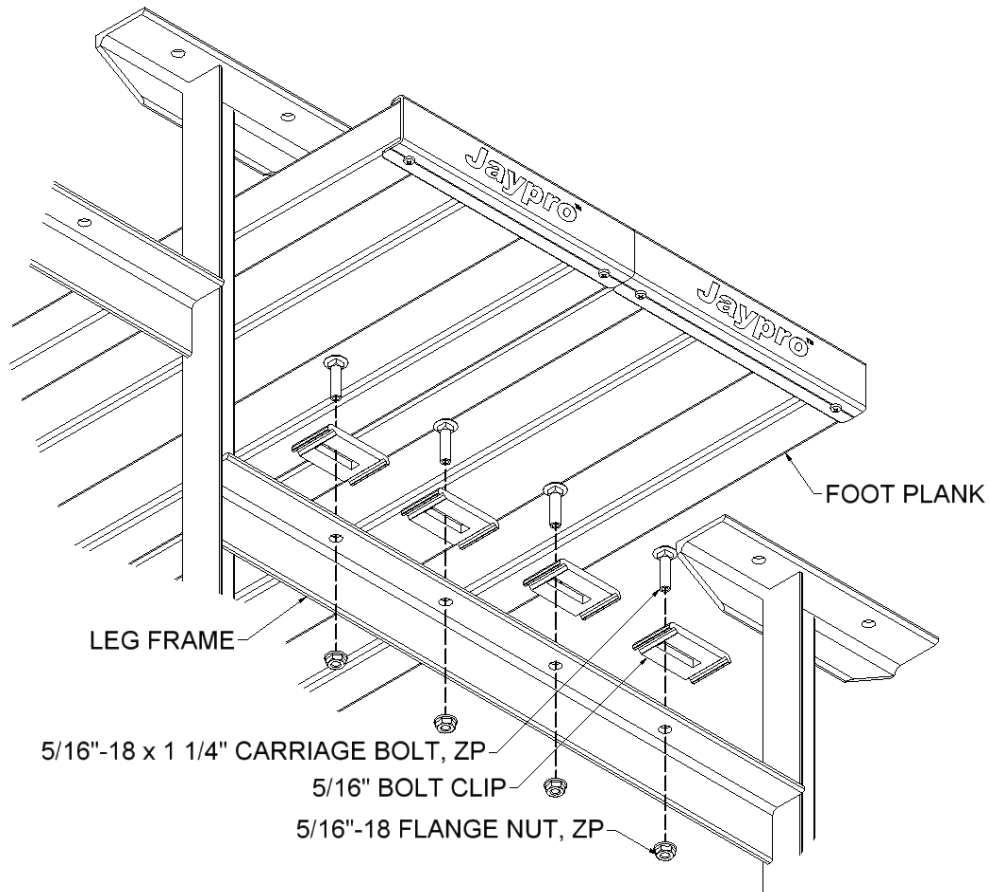

FIGURE: 7
(DOUBLE FOOT PLANK)

Final Adjustments:

- Checks to make sure the bleacher is properly aligned and square.
- Securely tightened all plank hardware.