

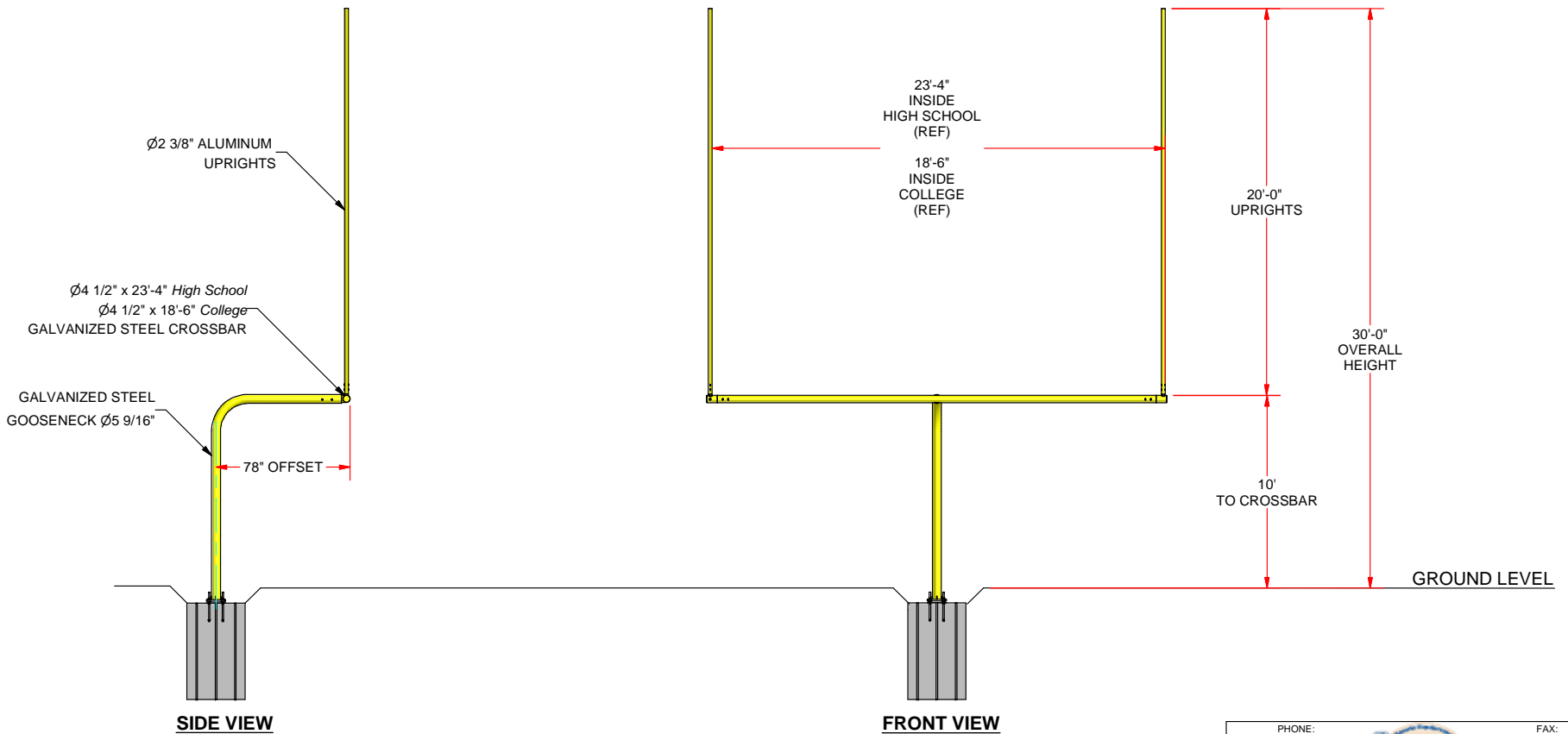

FBGP-700 FOOTBALL GOAL SPECIFICATIONS



SIDE VIEW

FRONT VIEW

FBGP-700	HIGH SCHOOL	WHITE
FBGP-700YW	HIGH SCHOOL	YELLOW
FBGP-700C	COLLEGE	WHITE
FBGP-700CYW	COLLEGE	YELLOW

PHONE: 800.243.0533 (TOLL FREE)		FAX: 800.444.1779 (SALES)	
860.447.3001 (LOCAL)		860.440.0628 (ENG.)	
			
<small>JAYPRO SPORTS, LLC, 976 HARTFORD TURNPIKE, WATERFORD, CT 06385 USA www.jaypro.com</small>			
DESCRIPTION FBGP-700 SPECIFICATIONS			
PART NUMBER FBGP-700	DWN BY DC	CHKD BY BTS	
SIZE B	SCALE N/A	DATE 7/11/2006	REV - SHEET 1 OF 1
<small>THIS DRAWING IS THE SOLE PROPERTY OF JAYPRO SPORTS INC. AND MAY NOT BE REPRODUCED WITHOUT WRITTEN PERMISSION OR CONSENT</small>			



**FBGP-700 SERIES
OFFICIAL 6' OFFSET FOOTBALL GOAL POST
-WITH LEVELING PLATE-**

LIST OF MATERIALS

<u>ITEM NO.</u>	<u>PART NO.</u>	<u>DESCRIPTION</u>	<u>QTY.</u>
1	HS5119	Bolt-HX HD ½"-13x5"	8
2	HS5066	Bolt-HX HD ½"-13x7 ¾"	4
3	HN268	½"-13 LOCK NUT	12
4	HW2044	½" FLAT WASHER	12
5	HS1616	Bolt-3/8"-16x2 ¾"	8
6	HN1230	3/8"-16 LOCK NUT	8
7	HW2047	3/8" FLAT WASHER	8
8	AF65	Top upright cap	4
9	FBGP601	ANCHOR ROD	8
10	HN5017	LOCK NUT 7/8"-9	8
11	HW5003	STANDARD FLAT WASHER 7/8"	16
12	HN5020	HEX NUT 7/8"-9	16
13	FBGP602	LEVELING PLATE	2
14	HS5161	RIVET 3/16"	2
15	WS-42RD	WIND STREAMER SET OF 4	1

IMPORTANT

- 1) The location of the gooseneck with respect to the field is critical. By rule, the front of the crossbar should be even with the field side (inside) edge of the end line such that the crossbars measure 360 ft apart, inside to inside. The distance from the end line to centerline of the bottom upright (gooseneck) is approximately **78"** for the FBGP-700 series. See Figure 1
- 2) The footing depth is 5'-8". Concrete should be a minimum 4000 psi mix. For installation see Figure 2.
- 3) The crossbar should be level and at a height of 10 ft above ground level. The uprights should be plumb in both directions, front to back and side to side. Adjust goal components as necessary. Note that a certain amount of deflection in the crossbar is to be expected due to the weight of the end fittings and uprights on each end.
- 4) It is strongly recommended that a Protective Post Pad be placed around the gooseneck when the goals are in use.

FOOTING INSTALLATION

- 1) Excavate the footing hole to the appropriate dimensions as shown in Figure 1 and 2 for locating the footing. Pour the footing, using minimum 4,000 psi mix, to within 8" from ground level.
- 2) Assemble anchor rod to leveling plate by installing 7/8"-9 hex nut onto anchor rod and engaging 7" of thread. Slip anchor rod thru holes in leveling plate orienting the anchor rod as shown. Install second 7/8"-9 hex nut onto anchor rod and tighten down so that the leveling plate is now held securely between the two nuts. Place into concrete, level and square.
- 3) Let the foundation cure for a minimum of 48 hours.

GOOSENECK INSTALLATION

- 1) Once the footing is complete and the concrete has set for 48 hours, rig the gooseneck onto the anchor bolts, as shown in Figure 2.
- 2) Adjust the height and plum the gooseneck. Secure all hardware. Note: Due to the weight of the crossbar and uprights the gooseneck will deflect downward 1" to 1 1/2".
- 3) All 7/8" -9 nuts and bolts should be coated with heavy grease. Each stud should be protected by placing heavy poly film over greased studs and wrapping with tape.

CROSSBAR AND UPRIGHT INSTALLATION

Crossbar Installation:



Use 10' scaffolding and a ladder, have two people on the scaffolding to lift and move the crossbar. Now with a third person on the ladder guide the insert into the gooseneck.



Insert crossbar into gooseneck. Set crossbar depth so the front edge of the crossbar is inline with the inside edge (field side) of the end line. Once the crossbar is level, mark (by using a center punch) and drill the holes through the gooseneck. Start with a 3/16" bit, then a 3/8" bit and finally a 1/2" bit.

Mark and Drill Crossbar:



Once the holes are drilled, use the 1/2" bolts with two flat washers and thin lock nut. Silicon is used on each side of the bolt to prevent corrosion.

Tightening ½” bolts between crossbar and gooseneck:



Top Upright Installation:

Place the end fitting in the end of the crossbar and plumb to level in two directions – front to back and side to side. Mark the holes using a center punch. **IMPORTANT:** It is important that the holes in the end fitting be properly placed to ensure that the end fittings are square and the uprights are parallel to each other.

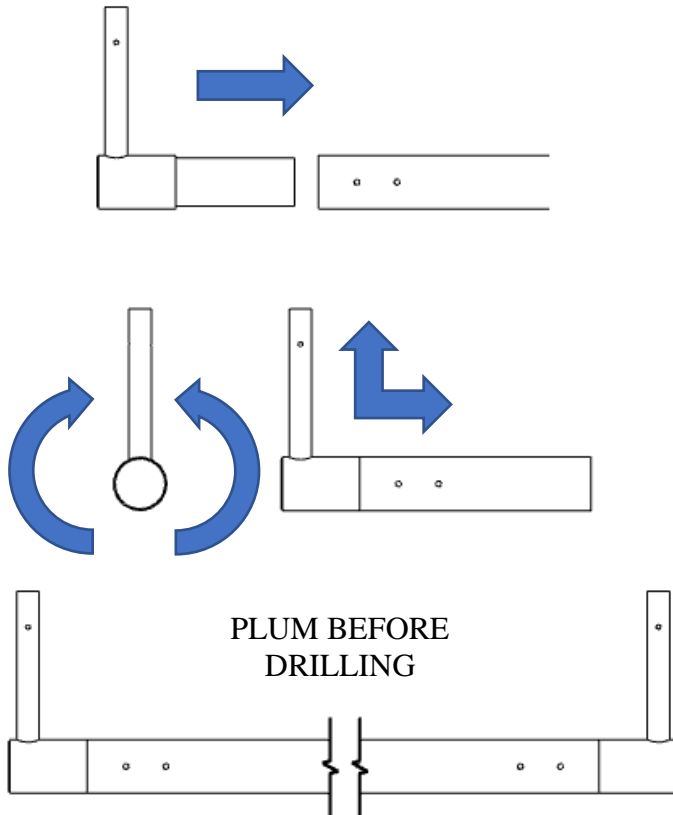

Remove the end fitting and drill the marked holes. Start with a 3/16” bit, then a 3/8” bit and finally a ½” bit.

Drill End Fitting:

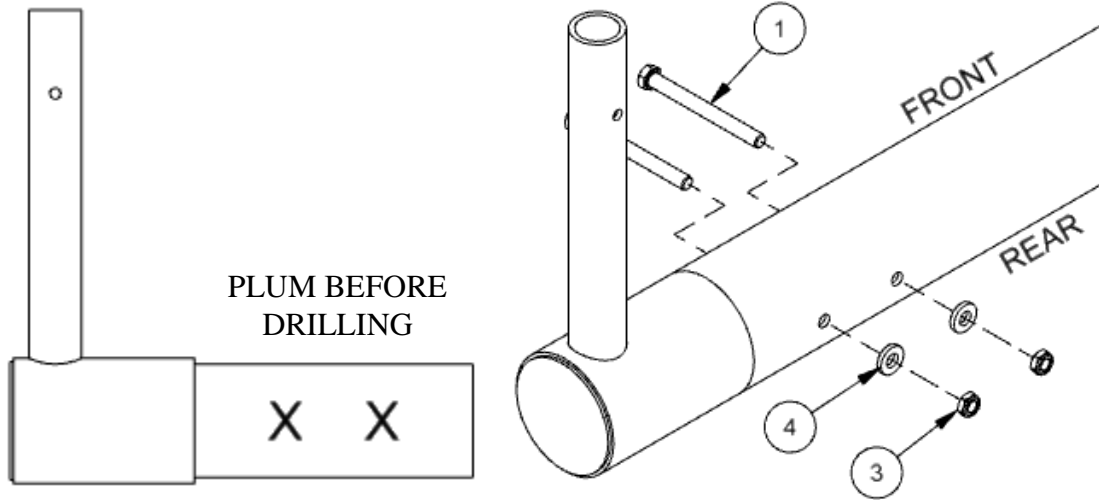

Insert the end fitting in crossbar and loosely install the appropriate hardware. Verify that the vertical member is square to the crossbar and plumb.

Attach top upright cap:

Install wind streamers by drilling a 5/16" diameter in the tip of the cap. Assemble wind streamers as shown below. Tap the cap in place and drill a 3/16" through the hole on the cap to the top upright. Use the rivet 3/16" provided and secure the cap.

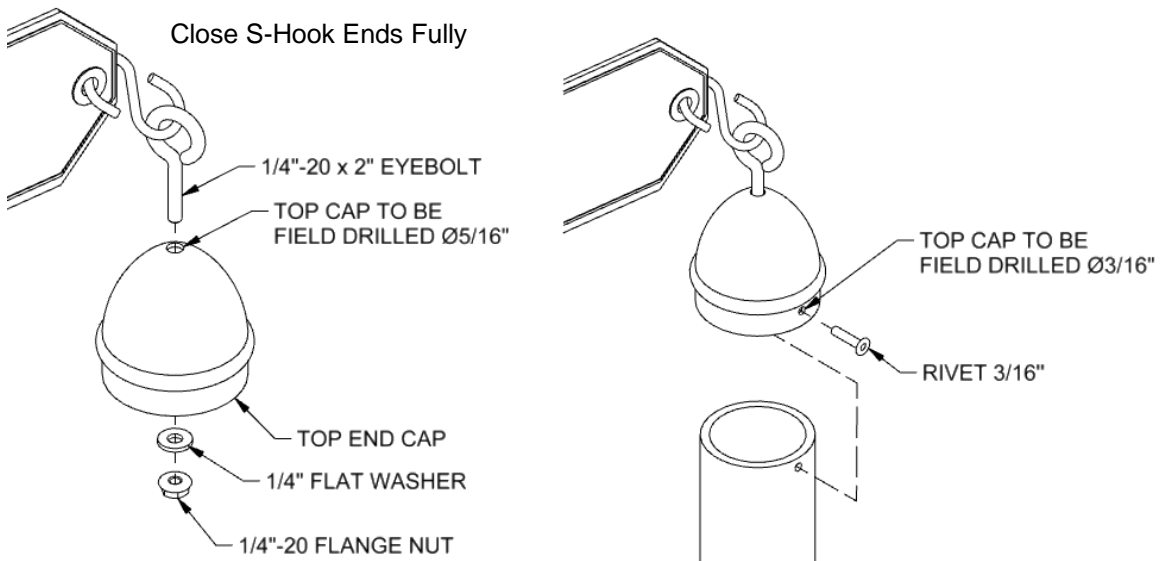

NOTE: Do Not Over-Tighten,
Streamer Must Spin Freely.

Install Top Upright:

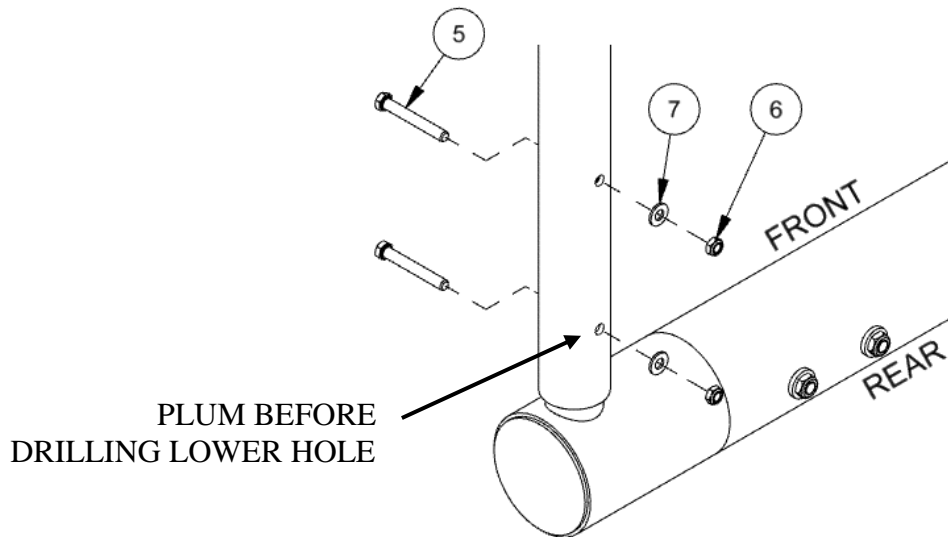
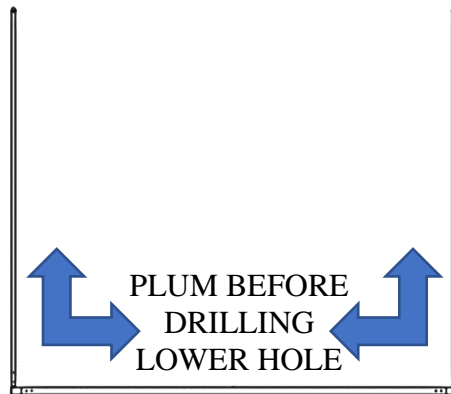

- Lift one upright onto the insert on the end Fitting.
- Install the 3/8" hardware through the upright and predrilled hole in end fitting insert.
- Plum the upright and drill the lower hole and install 3/8 hardware.



Once complete, repeat on the other side. After both goalposts are installed use yellow rustoluem to paint all of the bolt heads and all of the nuts. This will give the fasteners an extra layer of protection and it will give the goalpost a finished look, and also touch up any scratches.

