

**ASSEMBLY INSTRUCTIONS  
FUTSAL GOAL WHEEL KIT**

**TOOLS REQUIRED:**

- 9/16 inch BOX END WRENCH AND RATCHET
- 15/16 in BOX END WRENCH AND RATCHET
- DRILL AND 7/16 INCH DRILL BIT
- 4 inch C-CLAMP OPTIONAL

- 1) UNPACK ALL PARTS AND CHECK AGAINST PARTS LIST TO ENSURE THAT ALL PARTS HAVE BEEN INCLUDED
- 2) IF FUTSAL GOAL IS ALREADY PUT TOGETHER REMOVE THE TWO BOLTS HOLDING THE SQUARE BOTTOM CROSSBAR.
- 3) POSITION THE FIRST WHEEL ONTO THE BOTTOM CROSSBAR AS SHOWN IN THE ILLUSTRATION AND USING THE HOLE FROM THE BOLT YOU JUST REMOVED ASSEMBLE USING A 3 INCH LONG 3/8-16 HEX HEAD BOLT WITH WASHERS AND NUT AS SHOWN
- 4) USING THE WHEEL BRACKET AS A GUIDE DRILL A 7/16 INCH DIAMETER HOLE THROUGH THE CROSSBAR AND ASSEMBLE WITH A 3 INCH LONG 3/8-16 BOLT, WASHERS AND NUT . USE A 4 INCH C-CLAMP TO HELP STEADY THE BRACKET WHILE DRILLING
- 5) REPEAT STEPS 3 AND 4 ON THE OPPOSITE SIDE OF THE GOAL
- 6) ASSEMBLE THE WHEELS TO THE WHEEL BRACKETS AS SHOWN IN THE ILLUSTRATION, THE INSET HUB SIDE IS ASSEMBLED WITH TWO BUSHINGS AND CAN BE INSTALLED FACING INWARD OR OUTWARD OF THE GOAL

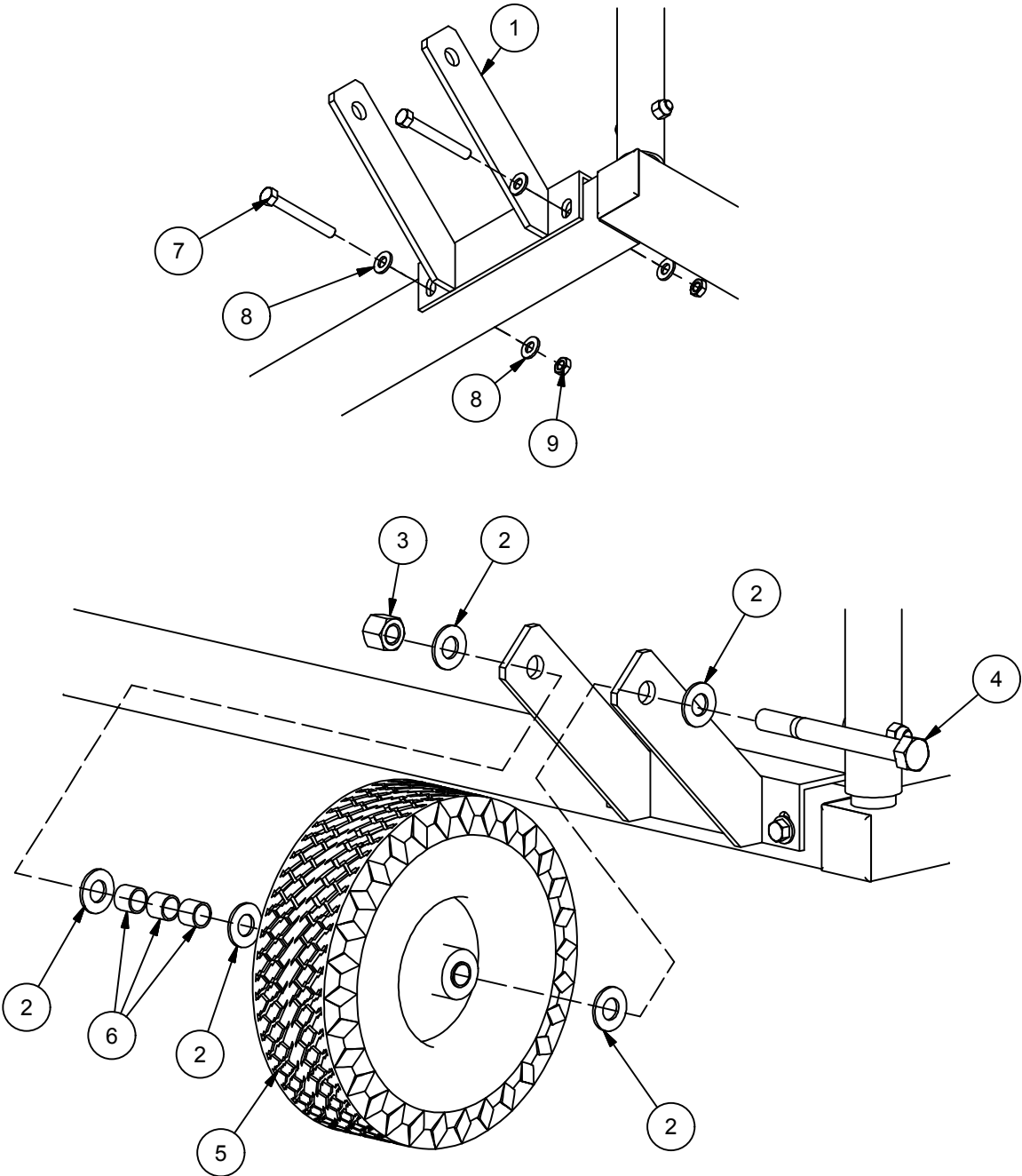

ITEM	QTY	PART #	DESCRIPTION
1	2	USG-20-42	WHEEL ASSEMBY KIT
2	10	HW2043	5/8" WASHER, ZP
3	2	HN2945	5/8"-11 NYLON LOCK NUT, ZP
4	2	HS5064	HEX BOLT - 5/8"-11 X 6" STEEL, ZP
5	2	RW5020D / RW5020I	WHEEL 10" x 4" NO FLAT TIRE
6	6	HM6039	5/8" I.D. x 3/4" O.D. x 5/8" LONG BEARING, BRNZ
7	4	HS4081	3/8"-16 x 3" HEX HD BOLT, ZP
8	8	HW2047	3/8" SAE FLAT WASHER, ZP
9	4	HN1230	3/8"-16 THIN NYLON LOCK NUT NTE, ZP

 976 Hartford Turnpike Waterford, CT 06385 USA (800)243-0533 Fax: (800)988-3363 www.jaypro.com		MODEL NUMBER: <b>FSGWK</b>	CHECKED BY: <b>WVB</b>
		PRODUCT NAME: <b>FUTSAL GOAL NO FLAT WHEEL KIT</b>	
DATE: <b>1/23/2013</b>	REV: <b>-</b>	DRAWN BY: <b>Moune T.</b>	SHEET: <b>1 OF 1</b>