

-- MPCTF-55D --

-- MPCTF-70D --

**55ft and 70ft MEGA POST & CABLE
OUTDOOR BATTING TUNNEL FRAME
CAGE**

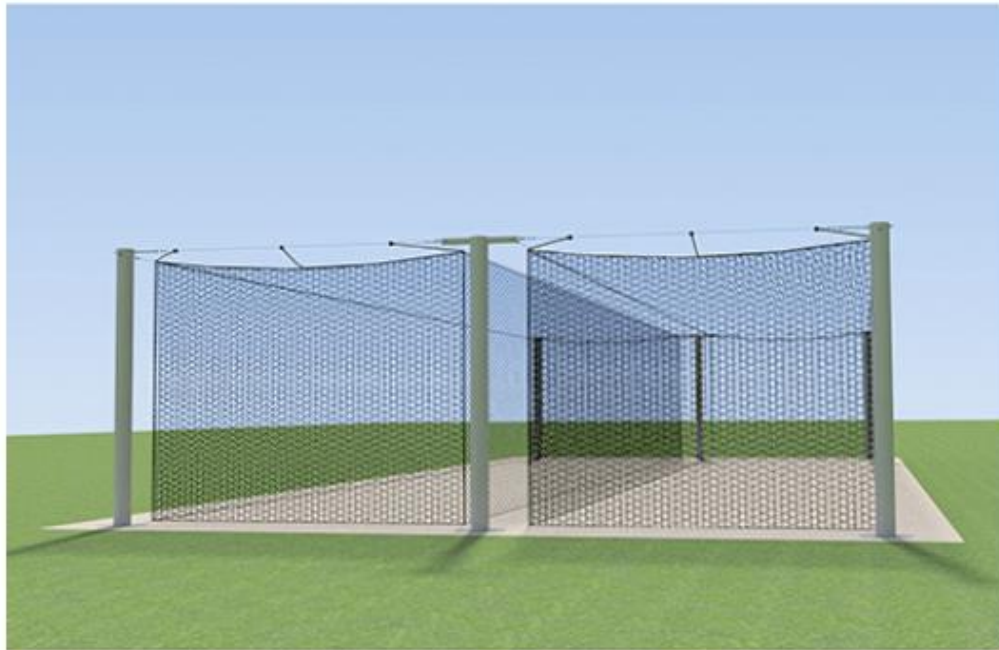





Installation Instructions



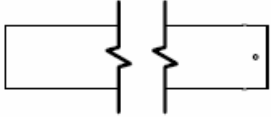



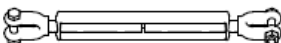

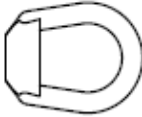

Call Jaypro Sports Equipment at 1-800-243-0533 during regular business hours for technical support.

www.jaypro.com

MEGA POST & CABLE OUTDOOR BATTING TUNNEL FRAME CAGE PARTS LIST (QTY: SINGLE UNIT)

| ITEM | IMAGE | DESCRIPTION | QTY |
|------|---|---|-----|
| 1 |  | 17'-0" UPRIGHT POST <i>P/N: MBT-8U</i> | 6 |
| 2 |  | CENTER BRACKET WELDMENT <i>P/N: MBT-8CUA</i> | 4 |
| 3 |  | 1/4" CABLE THIMBLE <i>P/N: HM6079</i> | 20 |
| 4 |  | 3/8" QUICK-LINK <i>P/N: HM6052</i> | 12 |
| 5 |  | 1/4" CABLE CLAMP <i>P/N: HM6078</i> | 48 |
| 6 |  | 1/2" GALV. TURNBUCKLE <i>P/N: HM6273</i> | 8 |
| 7 |  | 1/4" GALV. AIRCRAFT CABLE x 16 FT <i>P/N: RC5014</i> | 4 |
| 8 |  | 1/4" GALV. AIRCRAFT CABLE x 61 FT 70 FT cage uses 76 FT long aircraft cable. <i>P/N: RC5014</i> | 6 |
| ITEM | IMAGE | DESCRIPTION | QTY |

| ITEM | IMAGE | DESCRIPTION | QTY |
|------|---|---|------------|
| 9 |  | 1/2"-13 EYE NUT <i>P/N: HN5078</i> | 12 |
| 10 |  | 1/2"-13 x 10" LONG HEX BOLT <i>P/N: HS5384</i> | 8 |
| 11 |  | 1/2"-13 x 9" LONG HEX BOLT <i>P/N: HS5385</i> | 10 |
| 12 |  | 1/2"-13 x 5" LONG HEX BOLT <i>P/N: HS5062</i> | 4 |
| 13 |  | 1/2" STD FLAT WASHER <i>P/N: HW2044</i> | 44 |
| 14 |  | 1/2" SPLIT WASHER <i>P/N: HW2124</i> | 22 |
| 15 |  | 1/2"-13 HEX NUT <i>P/N: HN704</i> | 10 |
| 16 |  | SNAP HOOK (1/4" x 2 3/8") <i>P/N: HM5013</i> <i>70 FT cage uses 146 snap hooks.</i> | 116 146 |
| 17 |  | ALL-STAR SERIES TUNNEL NYLON NET <i>P/N: BBC36-5514 / BBC36-7014</i> | 1 |
| ITEM | IMAGE | DESCRIPTION | QTY |

IMPORTANT NOTICE:

1. BEFORE EACH USE CHECK EQUIPMENT FOR PROPER CONNECTING HARDWARE AND STRUCTURAL INTEGRITY. REPLACE DAMAGED OR MISSING HARDWARE IMMEDIATELY.
2. NEVER ALLOW ANYONE TO CLIMB OR HANG ON THE NET OR UPRIGHT POLE. AS SERIOUS INJURY OR DAMAGE TO THE EQUIPMENT MAY OCCUR.
3. USE OF THIS EQUIPMENT OTHER THAN INTENDED, MAY BE HAZARDOUS.
4. ALTERATION OR MODIFICATION OF THIS EQUIPMENT MAY BE HAZARDOUS AND RESULT IN INJURY. FOR REPAIR OR REPLACEMENT, CONTACT YOUR DEALER OR JAYPRO SPORTS.
5. NETS SHOULD BE REMOVED AND STORED AFTER THE SEASON IS OVER.
6. NETS SHOULD BE REMOVED PRIOR TO A MAJOR STORM OR HIGH WINDS.
7. THE RISK OF INJURIES CAN BE GREATLY REDUCED BY FOLLOWING PROPER SAFETY GUIDELINES, PROVIDING PROPER MAINTENANCE PERFORMING ROUTINE SAFETY INSPECTIONS ON THE NET, POLE AND HARDWARE.
8. SAFETY PRECAUTIONS AND ADULT SUPERVISION MUST BE OBSERVED AT ALL TIMES TO MINIMIZE THE POSSIBILITY OF ACCIDENTAL INJURES.
9. SPECTATORS MUST BE INSTRUCTED TO STAND A SAFE DISTANCE FROM THE NETTING WHEN THE BATTING CAGE IS IN USE, TO AVOID THE POSSIBILITY OF BODILY CONTACT WITH BALLS, BATS OR OTHER EQUIPMENT.
10. MAKE SURE NETTING DOESN'T CONTACT ANYTHING SOLID, SUCH AS A WALL OR CHAIN LINK FENCE.
11. TUNNEL NETS SHOULD BE REMOVED AND STORED PRIOR TO AN IMPENDING STORM WITH HIGH WINDS.
12. CONTACT JAYPRO SPORTS FOR REPLACEMENTS NETS AND HARDWARE

GENERAL MAINTENANCE:

- Batting tunnels nets should be removed and stored during the offseason or when not in use. Exposure to harsh winter weather will greatly reduce the life of a net.
- The tension cable and hardware should be closely inspected periodically, at the beginning and end of each season, or no less than twice a year.
- Any hardware that is corroded should be replaced immediately.
- Inspect each pole for rust and corrosion. If needed, brush area with a wire brush and repaint with an exterior grade rust-resistant enamel. If severe rust is noticed, particularly at the base, immediately stop using the cage. Loosen the cable tension and notify facility personnel.
- The cables may require periodic adjusting of the cable tension.
- The net should be closely inspected for wear and tears. Worn and weathered net, although still intact, lose their strength and ability to stop the ball. Replace any net that shows signs of wear or has tears or openings.

Tools Require:

- 1 3/4" and 3/8" Socket Wrench and Box Wrench
- 1 3/8" Nut Driver
- Unpack all parts and check against parts list to ensure that all have been included.
- Inspect all parts for damage. Report any damages to the trucking company.
 - * Extra screws are included, discard or stow away as needed.

I. Install Footing:

Note: See plan view for upright post layout, Figure 1.

- 1) Select a site for the tunnel frame that is flat and clear of obstructions. The ground should be level and free of debris. The minimum area required for a MPCTF-55D is 64 ft x 36 ft. - that required for MPCTF-70D is 79 ft x 36 ft.
- 2) Layout the foundations as shown in Figure 1. (Note: the MPCTF-55D layout is designed for a 55 ft long net, and the MPCTF-70D layout is designed for a 70 ft long net. Layout dimensions should be adjusted if using a different length net - the overall length of the frame should be 5 ft longer than the net.)
- 3) Dig footings as shown in Figure 2. A six-piece rebar basket is recommended. Pour a 6" concrete pad at the bottom of the footing, allow to cure for 24 hours.
- 4) Insert the pole, centered in the footings and support it in both directions.

Important: Verify the orientation of the holes in the top of the posts before proceeding. The upper holes should be in-line with the length of the net and the lower holes should line up with the ends of the net – see Figure 3.
- 5) Pour the concrete and allow it to cure for no less than 5 days before installing and tensioning the cables.

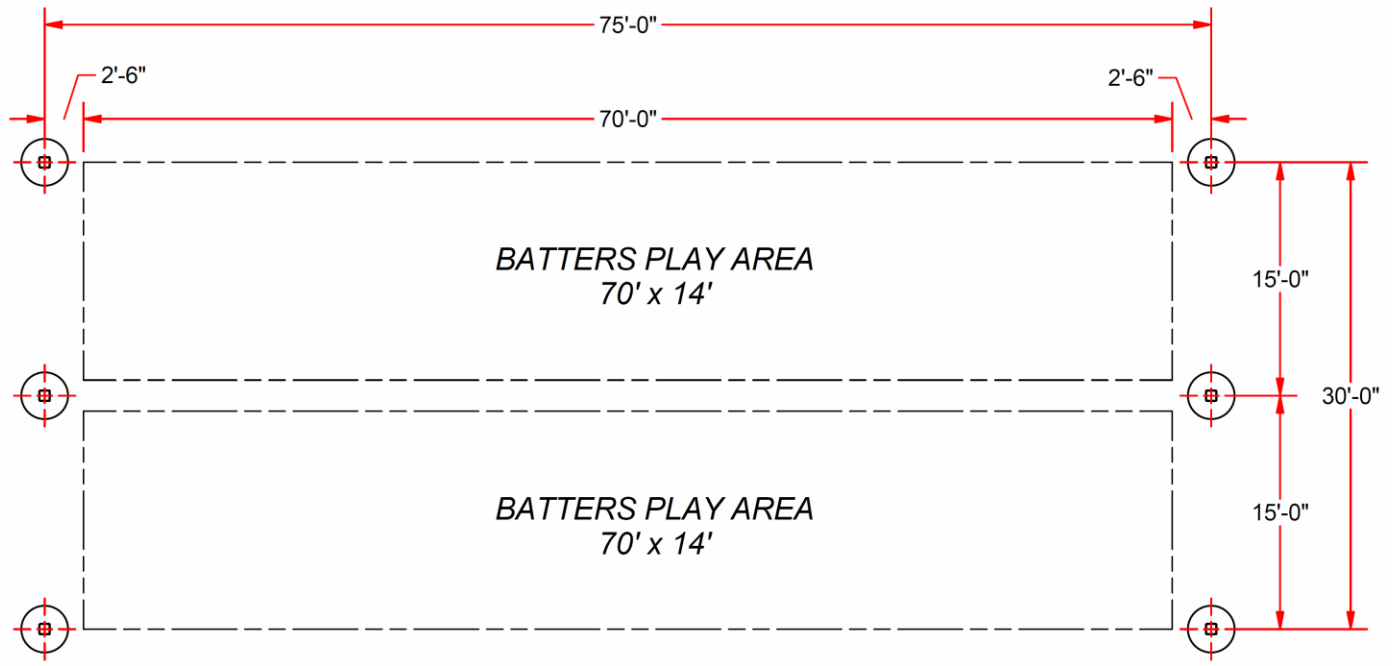
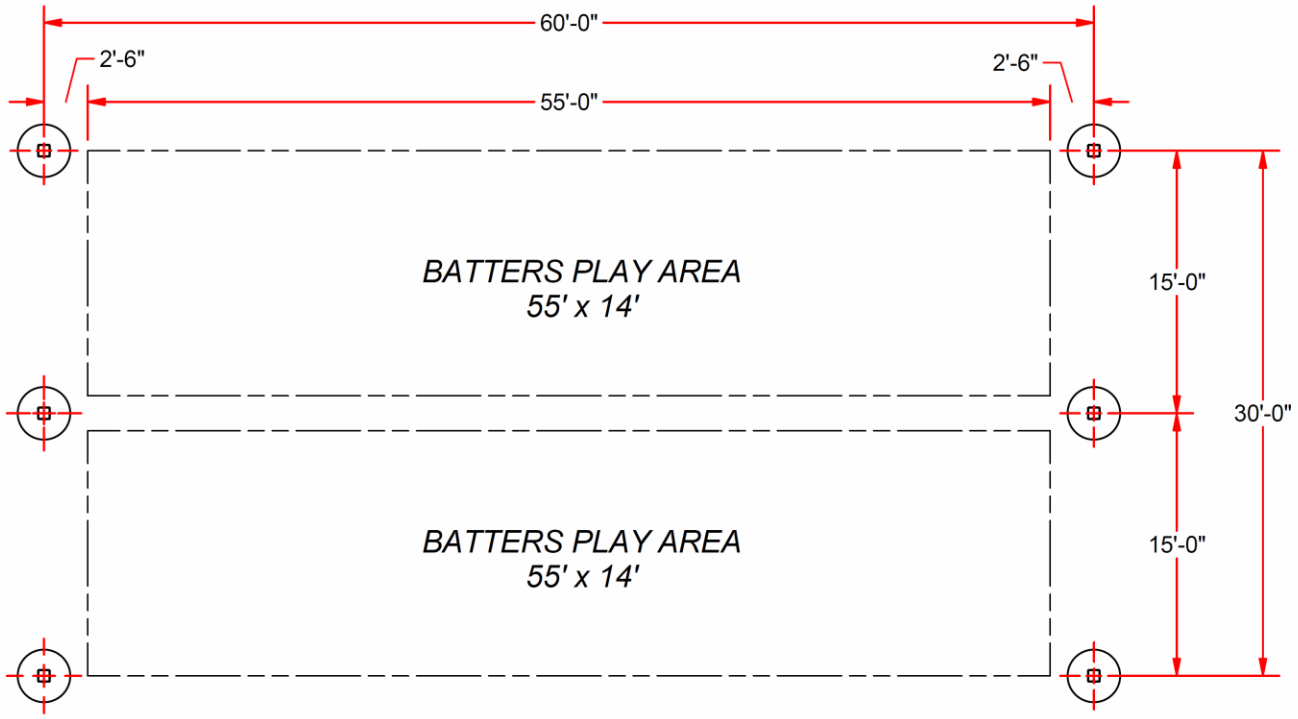

Figure 1

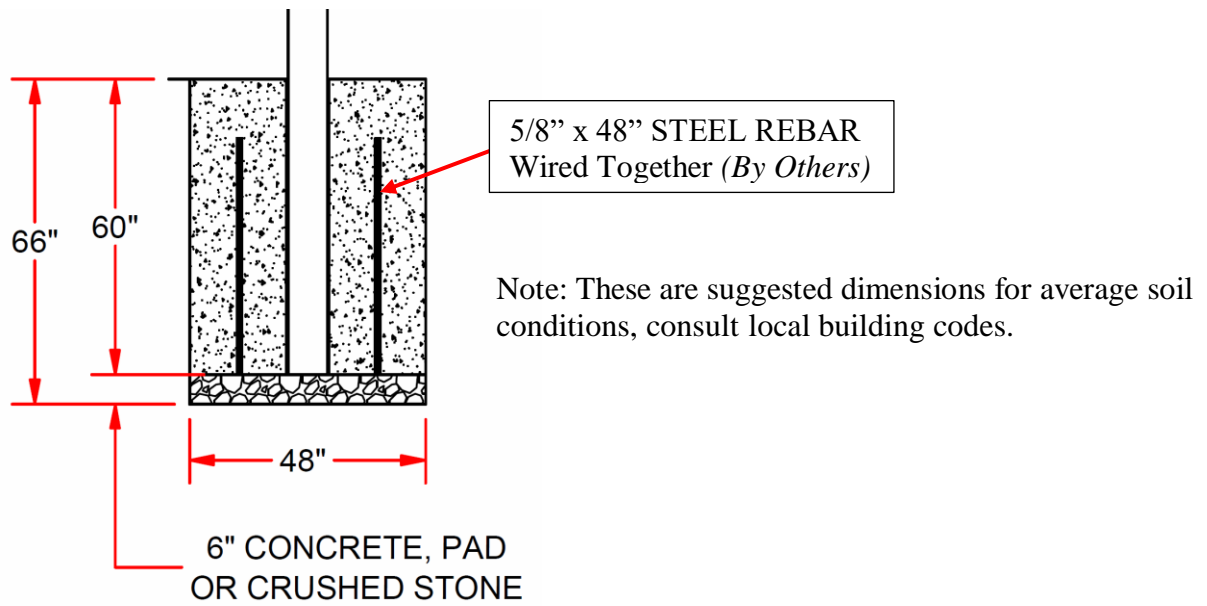

Figure 2

- **Before Digging,** Contact your local utility companies to locate buried electrical, gas, and water lines. Check for overhead utilities.
- Check local building codes before starting the footing, as building codes may vary. Local building codes should be adhered to if requirements are greater than those outlined here.
- Allow the concrete to fully cure, for no less than 5 days before installing tension cables.

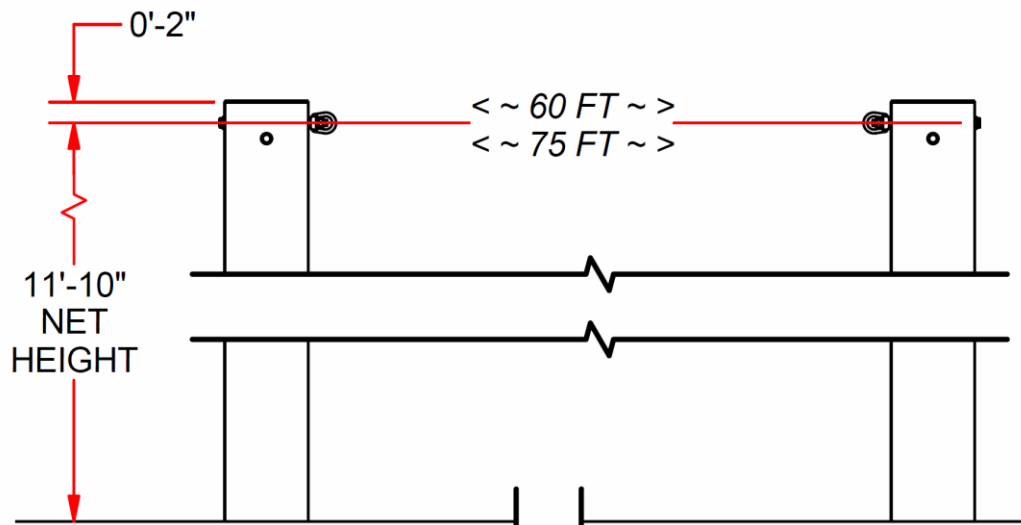

Figure 3

IMPORTANT: DO NOT POUR CONCRETE WITHOUT VERIFYING ORIENTATION OF THE POST HOLES. ENSURE THAT YOUR POST AGREES WITH FIGURE 3

II. Assembly:

Note: See Details A, B, C & D.

- 1) Make up the ends of the cable as shown in figure 4 of the 1/4" aircraft cable using thimbles & cable clamps. Note proper cable clamp positioning. Tighten the clamps on one end, but leave the other end somewhat loose to enable adjusting. Do not trim the cable yet. The cables should measure roughly 57'-10" or 72'-10" from thimble to thimble.
- 1) Install hardware on each pole as shown in Detail A, B, C & D. Each side of tunnel should consist of quick-link on one end and turnbuckle on the other (see Detail B). Extend the turnbuckles to their maximum length.
- 2) Attach the made up cable to the poles, attaching the fixed end of each cable to the quick-link and the free end to the turnbuckle. Lightly loosen the cable clamps and draw in the slack cable, pulling it as tight as you can. Tighten down the cable clamps and draw the cable tight using the turnbuckles. Repeat this step for all cables.
- 3) Roll out the net inside the frame. Center it and spread it out flat. Locate the rope border that runs along the top edge and down the center of the net.
- 4) Starting at one end, hang the net from the cables using the snap hooks, spaced approximately every 3'.
- 5) Once the net is completely hung tie off both ends using the rope leads extending from the net. Tie the net corners to the eye nuts on the posts. Position the net so it is centered from end to end.
- 6) Lastly, tie off the center rope to the cross cable, one each end, as shown in Detail D.

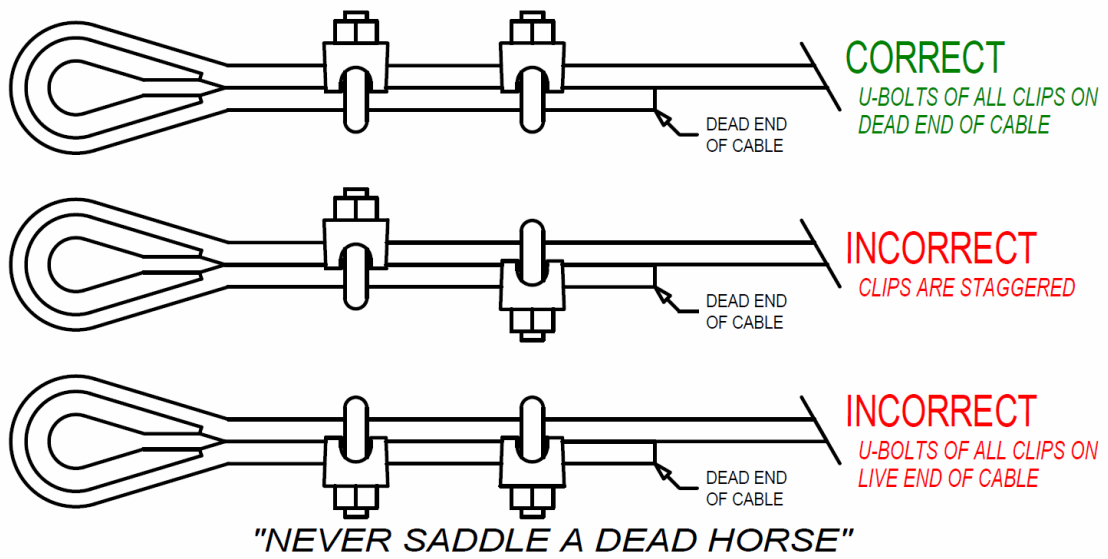
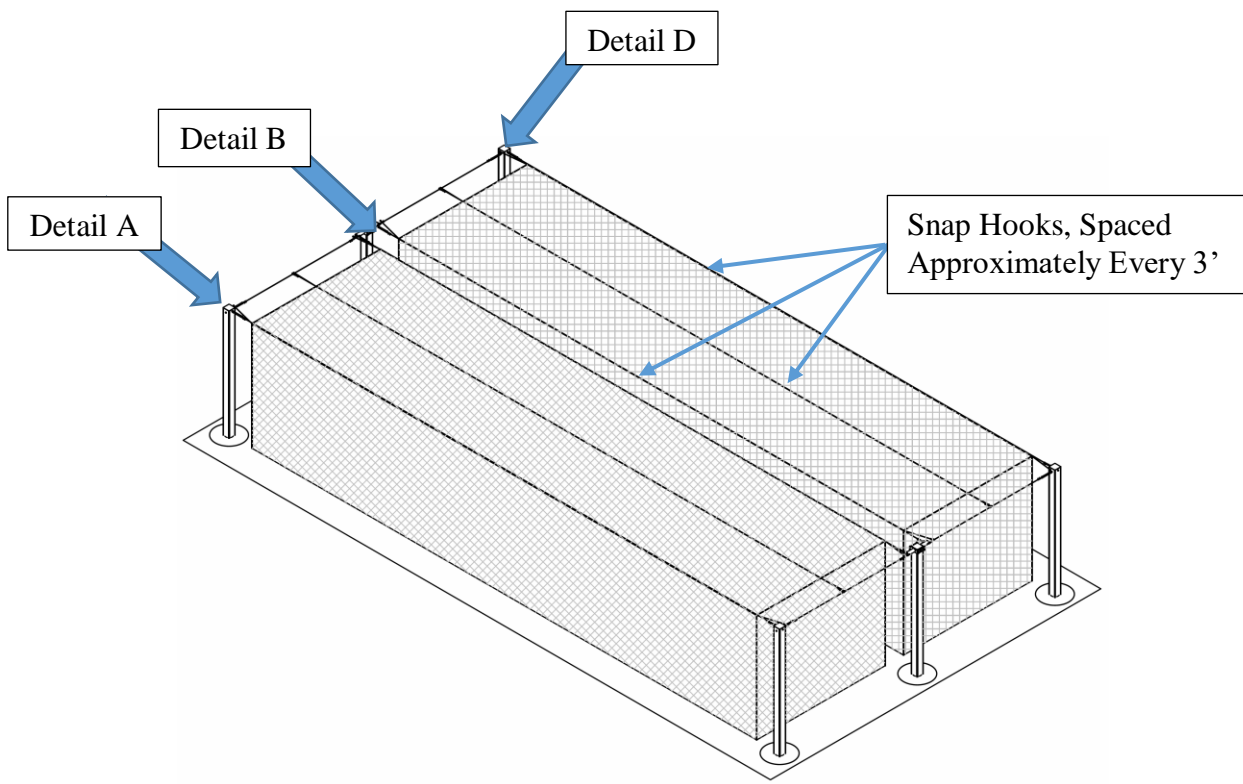
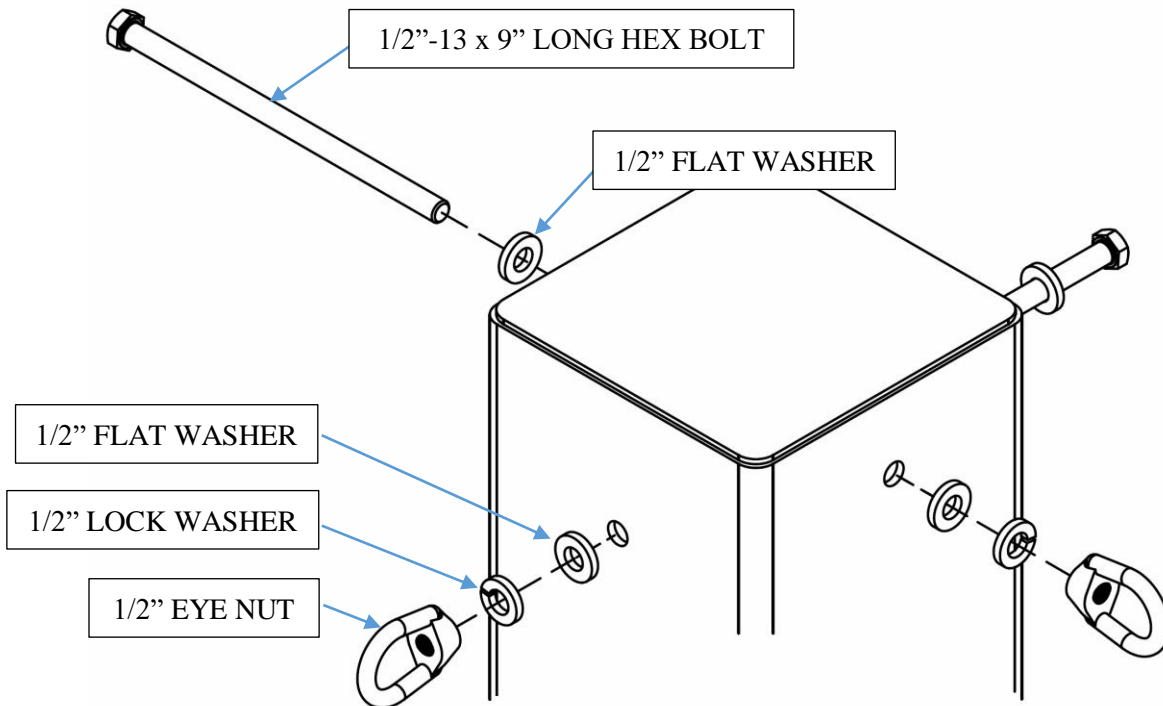
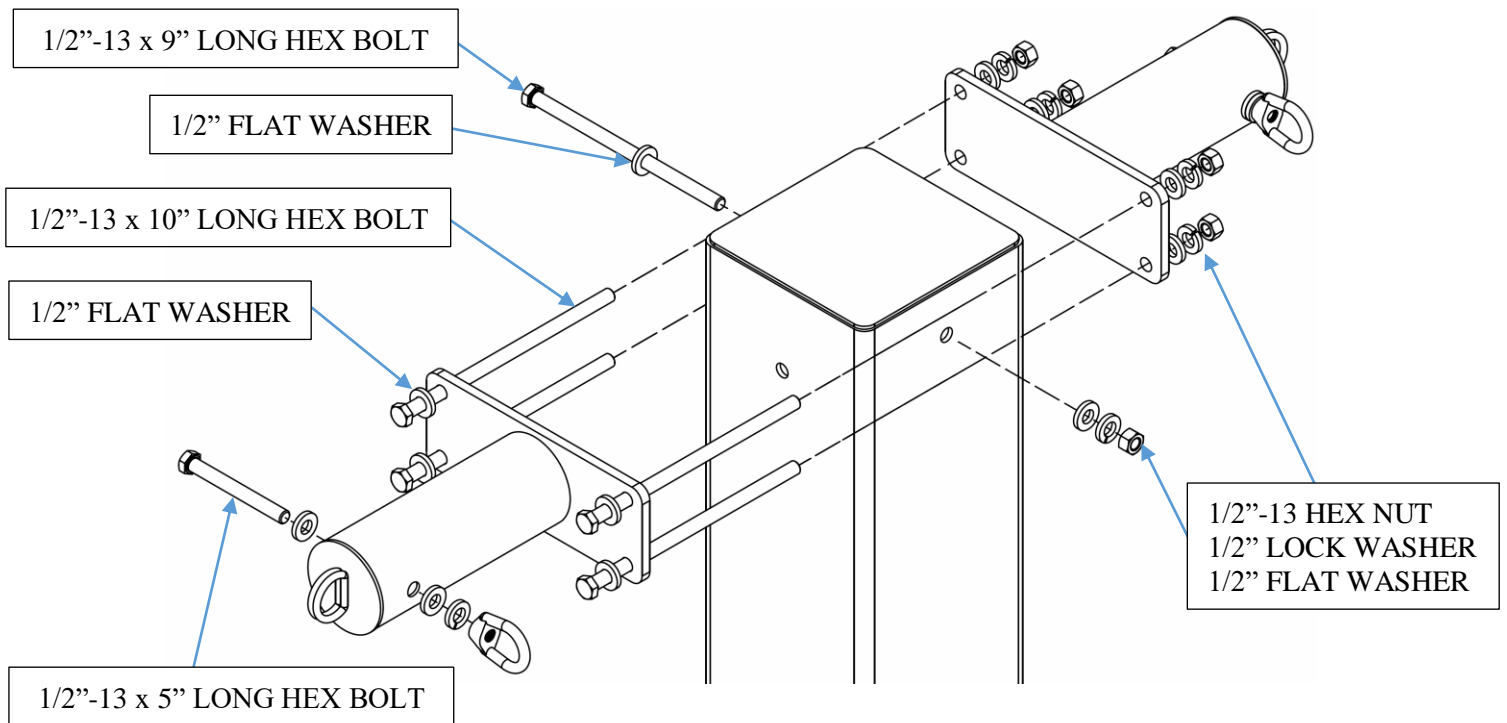

Figure 4



Detail A Typical Corner Post



Detail B Typical Center Post

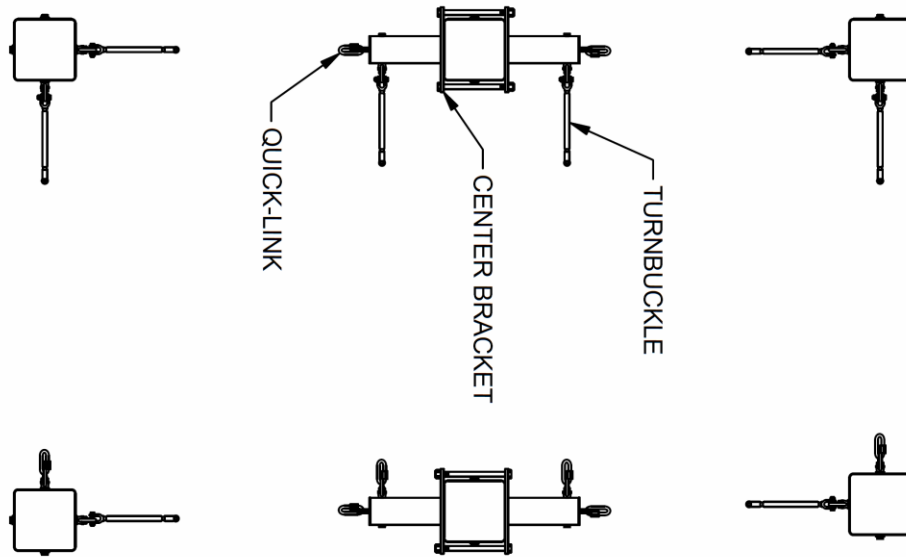

Detail C Plan View of Quick-Link & Turnbuckle

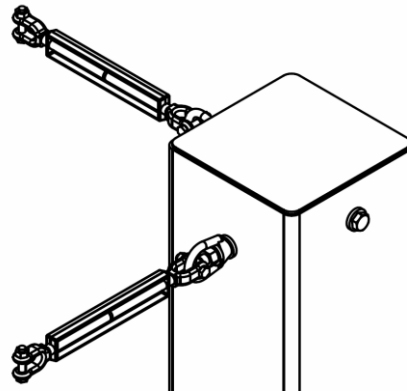

Corner Assembly

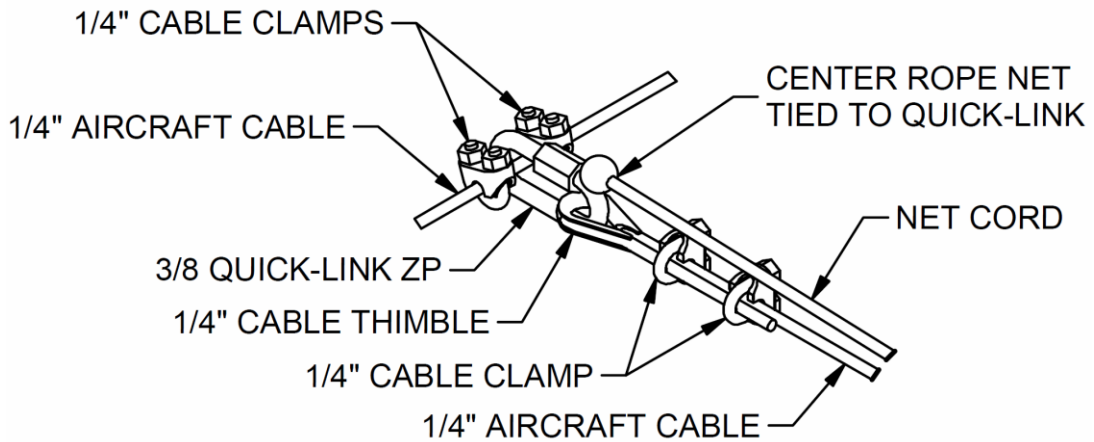

Detail D at center of net.