

# OCV-900 ECONOMY 3-1/2" DIA. STEEL OUTDOOR VOLLEYBALL SYSTEM

WELDED D-RING / BRACKETS FOR ATTACHING NET AT MEN'S & WOMEN'S HEIGHT



PVBN-3 or OBVN-2 VOLLEYBALL NET  
(SOLD SEPARATELY)

RATCHET WINCH

3 1/2" O.D. HEAVY WALL GALVANIZED STEEL UPRIGHT w/ POWDER COATED FINISH

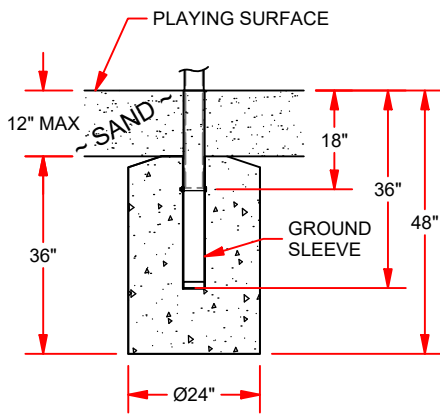

**SAND-FILLED FOOTING**  
\* DEPENDING ON SAND DEPTH  
(SHOWN ABOVE)

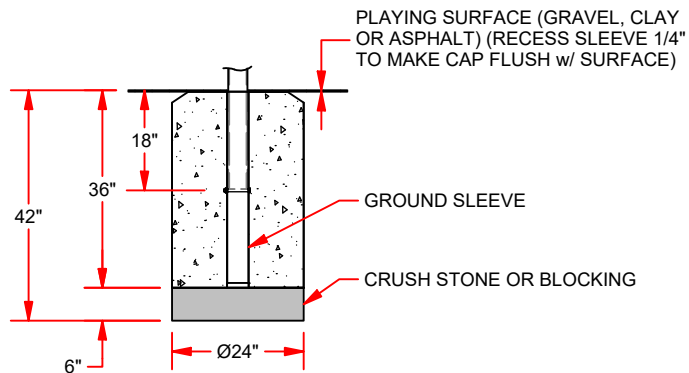

**NON-SAND FOOTING**  
(SHOWN ABOVE)

**FEATURES:**

- > 3-1/2" O.D. HEAVY WALL GALVANIZED STEEL UPRIGHTS
- > POWDER COATED SLIVER
- > FIXED HEIGHTS FOR MEN AND WOMEN'S PLAY.
- > RUST RESISTANT RATCHET AND 36" LONG ALUMINUM GROUND SLEEVES WITH COVER CAPS.
- > INCLUDES GROUND SLEEVES AND COVER.
- > NETS SOLD SEPARATELY (PVBN-3 or OBVN-2)
- > OPTIONAL CENTER PACKAGE AVAILABLE (OCV-900C).



**OCV-900**

ECONOMY 3-1/2" DIA. STEEL  
OUTDOOR VOLLEYBALL SYSTEM

© COPYRIGHT 2021 JAYPRO SPORTS, LLC. ALL RIGHTS RESERVED THIS PRINT IS THE PROPERTY OF JAYPRO SPORTS, LLC. AND MAY NOT BE REPRODUCED WITHOUT WRITTEN PERMISSION

[www.jayprosports.com](http://www.jayprosports.com)  
(800) 243-0533  
976 Hartford Turnpike  
Waterford, CT 06385 USA

Rev: A

SHEET 1 OF 1