

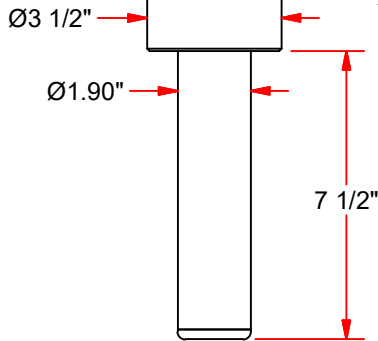

# PVB-5500 ADJUSTABLE HEIGHT VOLLEYBALL SYSTEM FOR 2" SLEEVE

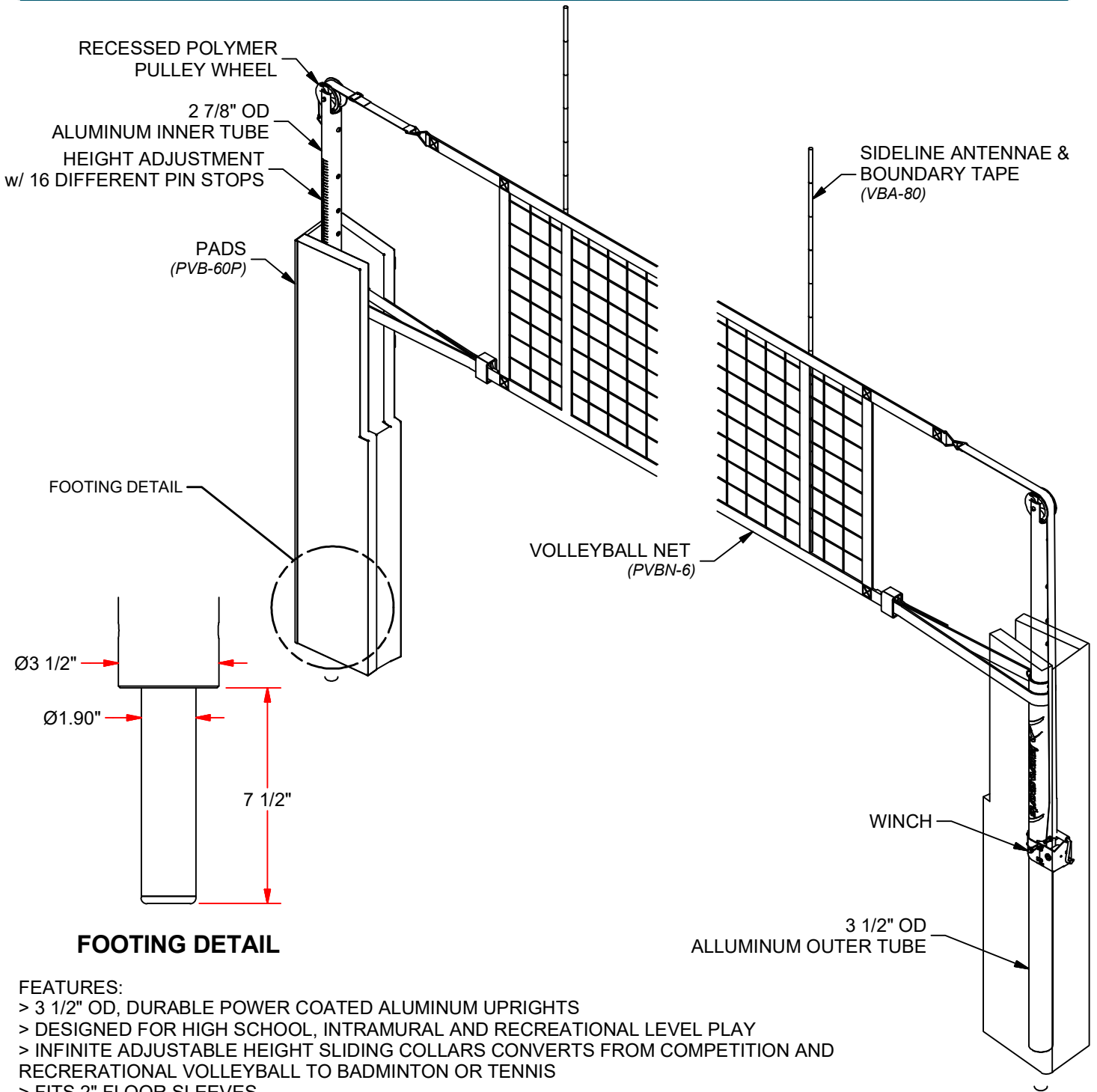

## FOOTING DETAIL

### FEATURES:

- > 3 1/2" OD, DURABLE POWER COATED ALUMINUM UPRIGHTS
- > DESIGNED FOR HIGH SCHOOL, INTRAMURAL AND RECREATIONAL LEVEL PLAY
- > INFINITE ADJUSTABLE HEIGHT SLIDING COLLARS CONVERTS FROM COMPETITION AND RECREATIONAL VOLLEYBALL TO BADMINTON OR TENNIS
- > FITS 2" FLOOR SLEEVES
- > COMPLETE SYSTEM INCLUDES UPRIGHTS WITH WORM DRIVE WINCH, NET, PADS AND ANTENNAE
- > INCLUDES:
  - PADS (PVB-60P) AVAILABLE IN DIFFERENT COLORS AND CUSTOM LETTING OPTIONAL.
  - VOLLEYBALL NET (PVBN-6)
  - ANTENNAE (VBA-80) VOLLEYBALL ANTENNA ADJUSTABLE / CLAMP ON
- > FOR UPRIGHTS AND WINCH ONLY (PVB-55U)



## PVB-5500

ADJUSTABLE HEIGHT VOLLEYBALL SYSTEM FOR 2" SLEEVE

© COPYRIGHT 2017 JAYPRO SPORTS, LLC. ALL RIGHTS RESERVED  
THIS PRINT IS THE PROPERTY OF JAYPRO SPORTS, LLC. AND MAY NOT BE REPRODUCED WITHOUT WRITTEN PERMISSION

www.jaypro.com  
(800) 243-0533  
976 Hartford Turnpike  
Waterford, CT 06385 USA