

ATTACH THE BOTTOM NET STRAP TO EACH UPRIGHT AS SHOWN. WRAP VELCRO STRAPS AROUND BUCKLES FOR ADDITIONAL PLAYER SAFETY.

### ILLUSTRATION #1

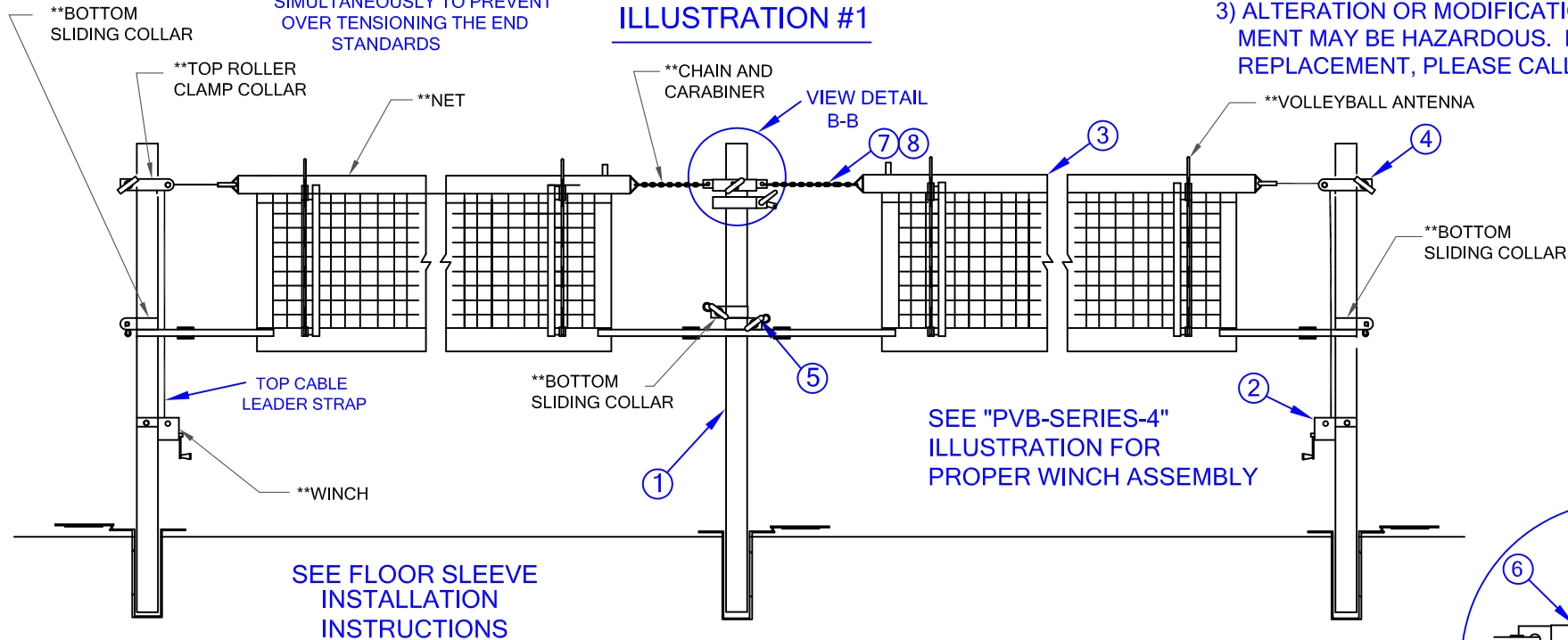

**IMPORTANT:**  
THE SIDE BY SIDE SYSTEMS MUST BE TENSIONED SIMULTANEOUSLY TO PREVENT OVER TENSIONING THE END STANDARDS

### PLEASE NOTE:

- 1) FOR SAFE OPERATION AND CONTINUED HIGH PERFORMANCE FROM THIS EQUIPMENT, INSPECTION AND MAINTENANCE MUST BE PERFORMED BEFORE EACH USE
- 2) USE OF THIS EQUIPMENT OTHER THAN INTENDED, MAY BE HAZARDOUS.
- 3) ALTERATION OR MODIFICATION OF EQUIPMENT MAY BE HAZARDOUS. FOR REPAIR OR REPLACEMENT, PLEASE CALL YOUR DEALER

SEE "PVB-SERIES-4" ILLUSTRATION FOR PROPER WINCH ASSEMBLY

SEE FLOOR SLEEVE INSTALLATION INSTRUCTIONS

USE DOUBLE TOP COLLAR (7) FOR SAME NET HEIGHT.  
USE \*\*ANCHOR END CLAMP COLLAR WITH DOUBLE TOP COLLAR (7) FOR DIFFERENT NET HEIGHTS.

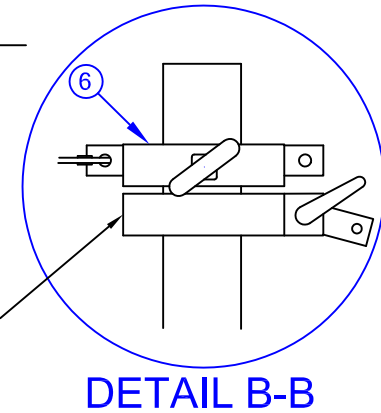

\*\* PART OF PVB-1350 SYSTEM

976 Hartford Turnpike  
Waterford, CT 06385 USA  
(800)243-0533 Fax: (800)988-3363  
www.jaypro.com

MODEL NUMBER: <b>PVB-130C</b>		CHECKED BY: WVB
PRODUCT NAME: <b>POWER VOLLEYBALL CENTER STANDARD</b>		
EFFECTIVE DATE: 12/7/10	DRAWN BY: DRL	REV: B

# JAYPRO SPORTS

## PVB-130C

### CENTER STANDARD MULTI-PURPOSE ALUMINUM NET SYSTEM

#### LIST OF MATERIALS

<u>ITEM</u>	<u>PART #</u>	<u>DESCRIPTION</u>	<u>QTY</u>
1	PVB-13-1	CENTER STANDARD UPRIGHT	1
2	PVBWINCH	WINCH	1
3	PVBN-6	VOLLEYBALL NETS	1
4	PVB-13-8	TOP ROLLER CLAMP COLLAR	1
5	PVB-13-9	BOTTOM SLIDING COLLAR	2
6	PVB-130C-6	DOUBLE TOP COLLAR	1
7	HM5019	CARABINER 3/8 x 4	2
8	CN0001-24	CHAIN 24 INCHES	1

#### **BEFORE YOU START**

THIS TWO COURT SYSTEM IS MADE UP OF A MULTI PURPOSE VOLLEYBALL SYSTEM MODEL PVB-1350 ALONG WITH THE PVB-130C CENTER STANDARD PACKAGE. SINCE BOTH OF THESE PACKAGES ARE NORMALLY PURCHASED AND ASSEMBLED AT THE SAME TIME THESE INSTRUCTIONS TAKE YOU THROUGH THE ASSEMBLY OF BOTH PACKAGES AS A SINGLE PACKAGE.

#### **UNPACKING**

1. UNPACK ALL PARTS AND CHECK AGAINST THE LISTS TO ENSURE THAT ALL PARTS HAVE BEEN INCLUDED.
2. INSPECT FOR DAMAGE. REPORT ANY AND ALL DAMAGES TO TRUCKING COMPANY.

#### **UPRIGHT ASSEMBLY**

1. ASSEMBLY OF UPRIGHTS IS DONE MOST EASILY WITH THE HELP OF A COUPLE OF SAW HORSES OR A SIX-FOOT FOLDING TABLE. LAY THE THREE UPRIGHTS ON THE SAW HORSES. (BE CAREFULL THE UPRIGHTS DO NOT ROLL OFF AS THEY COULD CAUSE SERIOUS INJURY) YOU WILL NOTICE THAT THEY ARE ALL IDENTICAL AND THE END WITH THE WHITE PLASTIC PLUG IS THE FOOT.
2. ASSEMBLE THE WINCHES ON TWO OF THE UPRIGHTS (SEE THE WINCH ASSEMBLY DIRECTIONS **PVB SERIES** AND FOLLOW INSTRUCTIONS FOR THE 3 1/2 INCH UPRIGHT). THE WINCHES ARE ADDITIONALLY SECURED TO THE UPRIGHTS WITH 4 1/2 INCH LONG BOLTS AND NUTS THAT ARE PROVIDED WITH THE UPRIGHTS.
3. ON EACH OF THE TWO UPRIGHTS YOU'VE JUST ATTACHED WINCHES, SLIDE A BOTTOM SLIDING COLLAR AND A TOP ROLLER CLAMP COLLAR. PLACE THESE COLLARS AT THEIR APPROXIMATE PLAYING POSITION (SEE DIAGRAM) AND LOOSELY TIGHTEN. YOU WILL FINE TUNE THEIR LOCATION LATER
4. ON THE REMAINING UPRIGHT FROM THE TOP (IN THIS ORDER) SLIDE TWO BOTTOM SLIDING COLLARS, THE ANCHOR END CLAMP, AND LASTLY THE DOUBLE TOP COLLAR. PLACE IN THEIR APPROXIMATE PLAYING POSITION AND AGAIN JUST LOOSELY TIGHTEN.
5. PLACE THE UPRIGHTS IN THE GROUND SLEEVES (SEE INSTRUCTIONS INCLUDED WITH SLEEVES FOR THEIR INSTALLATION) SEE DIAGRAM FOR WINCH AND COLLAR ORIENTATIONS.

## **ATTACHING NETS**

1. SLIP THE NET DOWELS INTO THE SIDE POCKETS OF EACH END OF THE NETS, AND POSITION A NET BETWEEN EACH PAIR OF UPRIGHTS.
2. THREAD THE WEBBING STRAP FROM THE WINCH OVER THE ROLLER CLAMP AND CONNECT THE DELTA RING FROM THE NET TO THE SNAP RING. CONNECT THE OTHER END OF THE NET DELTA RING TO A CARABINER AND LENGTH OF CHAIN THEN ATTACH THE CHAIN TO THE CARABINER ATTACHED TO EITHER THE ANCHOR END CLAMP COLLAR OR THE DOUBLE TOP COLLAR. THIS IS YOUR FIRST OPPORTUNITY TO CENTER THE NET IN BETWEEN THE UPRIGHTS. YOU WILL FINE TUNE THE CENTERING OF THE NET AS YOU COMPLETE THE ATTACHMENT. REPEAT THIS STEP FOR THE SECOND NET.
3. THE NET WILL STRETCH ~6 TO 8 INCHES WHEN TENSION IS APPLIED AND MUST BE FACTORED IN BEFORE APPLYING TENSION AND WHEN CENTERING THE NET.
4. SLOWLY TENSION THE TOP-WEBBING STRAP BY CRANKING THE WINCH WITH THE WINCH HANDLE. ADJUST THE CHAIN AS NECESSARY TO KEEP THE NETS CENTERED.
5. THE UPRIGHTS WILL DEFLECT INWARD AND DOWNWARD DUE TO NET TENSION. YOU MAY NEED TO ADJUST HEIGHTS AND/OR RE-CENTER THE NET. FOR BEST RESULTS, GRADUALLY TIGHTEN EACH WINCH UPRIGHT SO ALL THE TENSION IS NOT ON ONE COURT ONLY.
6. ATTACH THE BOTTOM NET STRAPS BY WRAPPING THE LONG ENDS OF THE NET SIDE STRAPS AROUND THE UPRIGHTS BELOW THE BOTTOM SLIDING COLLARS AND FASTEN THEM THROUGH THE BUCKLES LOCATED ON THE OPPOSITE SIDE. WRAP THE VELCRO STRAPS AROUND BUCKLES FOR ADDED PLAYER SAFETY (**SEE ILLUSTRATION #1**). ADJUST THE SIDE STRAPS SO THAT THE VOLLEYBALL NET WILL BE CENTERED WITHIN THE PLAYING AREA.
7. RAISE THE CENTER OF THE NET TO FULL OFFICIAL NET HEIGHT BY CRANKING THE HANDLE. ADJUST ALL NET SIDE STRAPS TO FURTHER TENSION THE NET.
8. FOR PLAYER SAFETY CUT ANY EXCESS CHAIN BEFORE PUTTING SYSTEM INTO SERVICE.

## **REMOVAL AND STORAGE**

1. WHEN RELEASING THE TENSION ON THE UNIT UN-FASTEN THE BOTTOM STRAPS FIRST, THEN RELEASE THE TENSION ON THE TOP.
2. TO REMOVE THE UNIT FOR STORAGE, DISCONNECT THE NETS FROM THE UPRIGHTS AND CAREFULLY LIFT EACH UPRIGHT FROM THE FLOOR SLEEVE.

## **WARNINGS**

1. SYSTEM SHOULD NOT BE USED UNTIL THE UPRIGHT SAFETY PADS HAVE BEEN PROPERLY INSTALLED **SEE PVB-10**
2. **RELEASE TENSION FROM THE NET BEFORE LOOSENING ANY HARDWARE FROM THE UPRIGHTS.**
3. THE UNIT IS DESIGNED FOR HIGH LEVEL COMPETITION PLAY. CONSEQUENTLY, WHEN INSTALLED AND OPERATIONAL, THE UNIT IS SUBJECT TO CONSIDERABLE STRESS LOADS. INSPECTION AND MAINTENANCE MUST BE PERFORMED BEFORE EACH USE.
4. ALTERATIONS OR MODIFICATION OF EQUIPMENT MAY BE HAZARDOUS. FOR REPAIR OR REPLACEMENT, PLEASE CALL YOUR DEALER
5. USE OF THIS EQUIPMENT OTHER THAN INTENDED, MAY BE HAZARDOUS

### 3 1/2" UPRIGHT

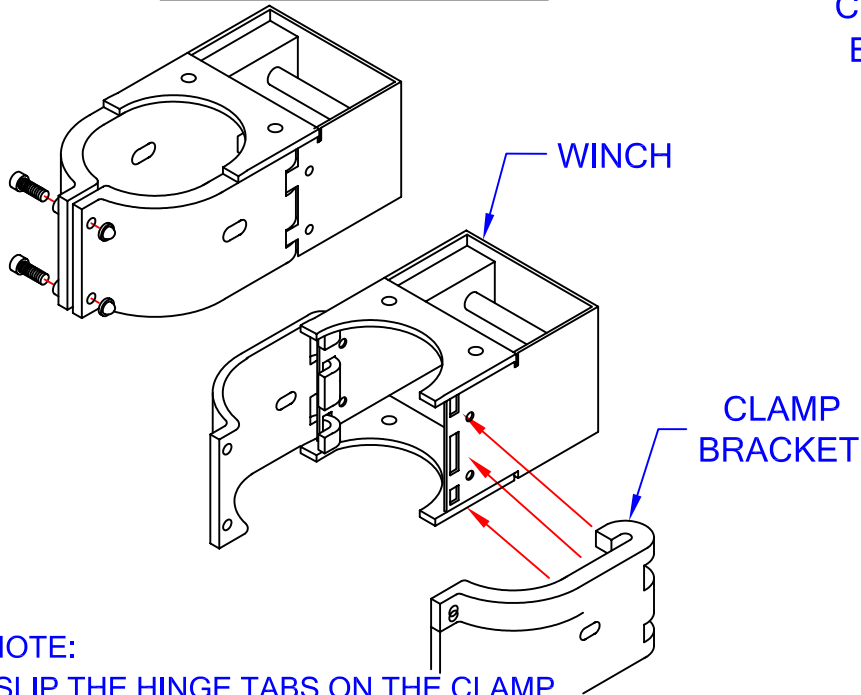

- NOTE:**
- SLIP THE HINGE TABS ON THE CLAMP BRACKET INTO THE HINGE SLOTS ON THE WINCH HOUSING.
  - OPEN THE CLAMPS AND PLACE THE WINCH ASSEMBLY ONTO THE VOLLEYBALL STANCHION. ALIGN SLOT IN CLAMP BRACKET WITH MOUNTING HOLES ON STANCHION.
  - FIRMLY SECURE THE CLAMP BOLTS THEN ADD THE CAP NUTS TO COVER THE ENDS OF EACH CLAMP BOLT. SEE "PVB-SERIES-2" ILLUSTRATION FOR WINCH MOUNTING DETAILS.

FOR MODELS: PVB-5000  
 PVB-7000  
 PVB-6500  
 PVB-2500  
 PVB-2700

### 3" UPRIGHT

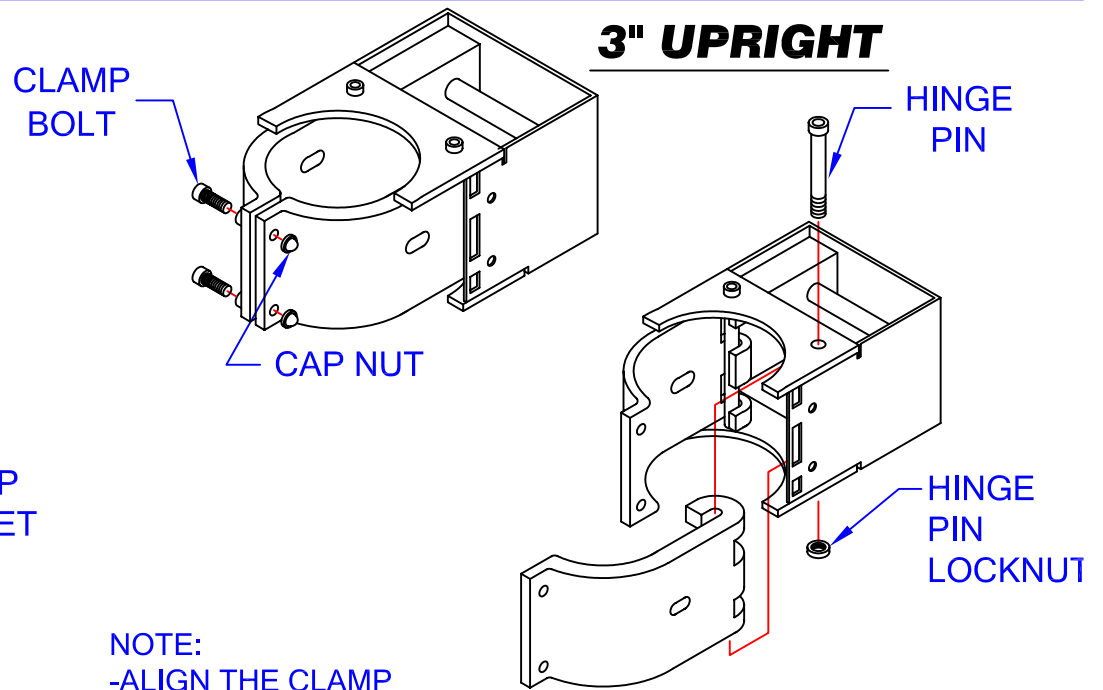

- NOTE:**
- ALIGN THE CLAMP BRACKETS TO THE INSIDE OF THE WINCH HOUSING, SLIP THE HINGE PIN THRU THE HINGE TABS OF THE CLAMP BRACKET, THEN SECURELY FASTEN WITH THE HINGE PIN LOCKNUT.
  - SLIDE THE WINCH ASSEMBLY ONTO THE VOLLEYBALL STANCHION AND ALIGN SLOT IN CLAMP BRACKET WITH MOUNTING HOLES ON STANCHION.
  - FIRMLY SECURE THE CLAMP BOLTS THEN ADD THE CAP NUTS TO COVER THE ENDS OF EACH CLAMP BOLT. SEE "PVB-SERIES-2" ILLUSTRATION FOR WINCH MOUNTING DETAILS.

FOR MODEL: PVB-6000



976 HARTFORD TURNPIKE  
 WATERFORD, CT 06385 USA  
 www.jaypro.com

MODEL NAME: <b>PVB-SERIES</b>		CHECKED BY: <b>WVB</b>
DESCRIPTION: <b>WINCH ASSEMBLY</b>		
DATE: <b>5-6-03</b>	REV <b>-</b>	DRAWN BY: <b>JAC</b>

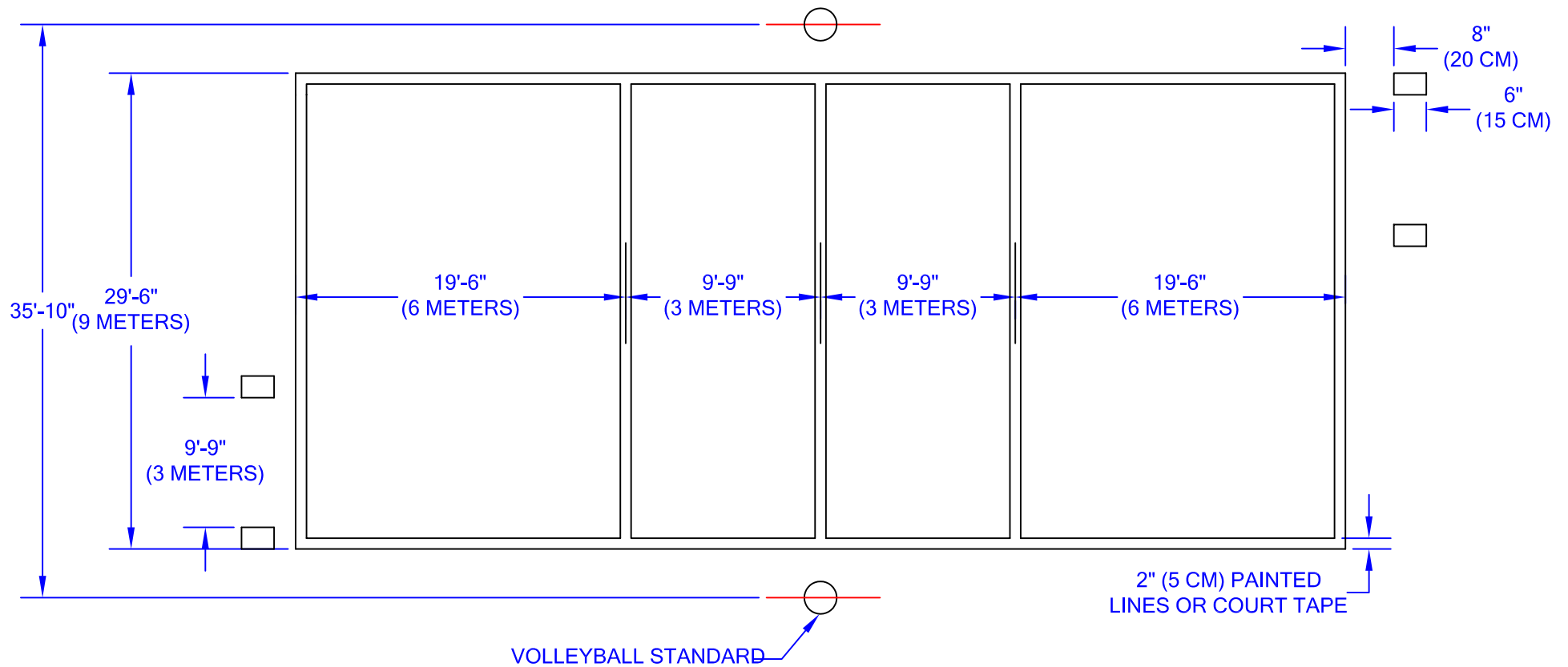

**IMPORTANT:**  
 COURT DIMENSIONS SHOWN COMPLY WITH SPECIFICATIONS FOR:  
 U.S.V.B.A.  
 F.I.V.B.  
 N.C.A.A.  
 COURT SIZE SPECIFICATIONS FOR THE N.F.S.H.S.A. ARE 30'W x 60'L.  
 CENTER LINE TO BE 4" WIDE.  
 SPIKE LINE TO BE 10' FROM THE CENTER LINE.  
 SERVING AREA TO BE 10' LONG.

**Jaypro**

976 HARTFORD TURNPIKE  
 WATERFORD, CT 06385 USA  
 www.jaypro.com

PVB-1000

CHECKED BY:  
**WVB**

**POWER VOLLEYBALL  
 COURT LAYOUT**

REV

-

**ASSEMBLY INSTRUCTIONS:**

1. INSTALL POWER VOLLEYBALL SYSTEM AS DESCRIBED IN SEPERATE INSTRUCTIONS

2. PLACE PADS INTO POSITION, AS SHOWN, AND SECURELY FASTEN THE VELCRO CLOSURES AS INDICATED

**CAUTION:**

DO NOT USE THE POWER VOLLEYBALL SYSTEM WITHOUT THE UPRIGHT PADS

**PLEASE NOTE:**

- 1) FOR SAFE OPERATION AND CONTINUED HIGH PERFORMANCE FROM THIS EQUIPMENT, INSPECTION AND MAINTENANCE MUST BE PERFORMED BEFORE EACH USE
- 2) USE OF THIS EQUIPMENT OTHER THAN INTENDED, MAY BE HAZARDOUS.
- 3) ALTERATION OR MODIFICATION OF EQUIPMENT MAY BE HAZARDOUS. FOR REPAIR OR REPLACEMENT, PLEASE CALL YOUR DEALER

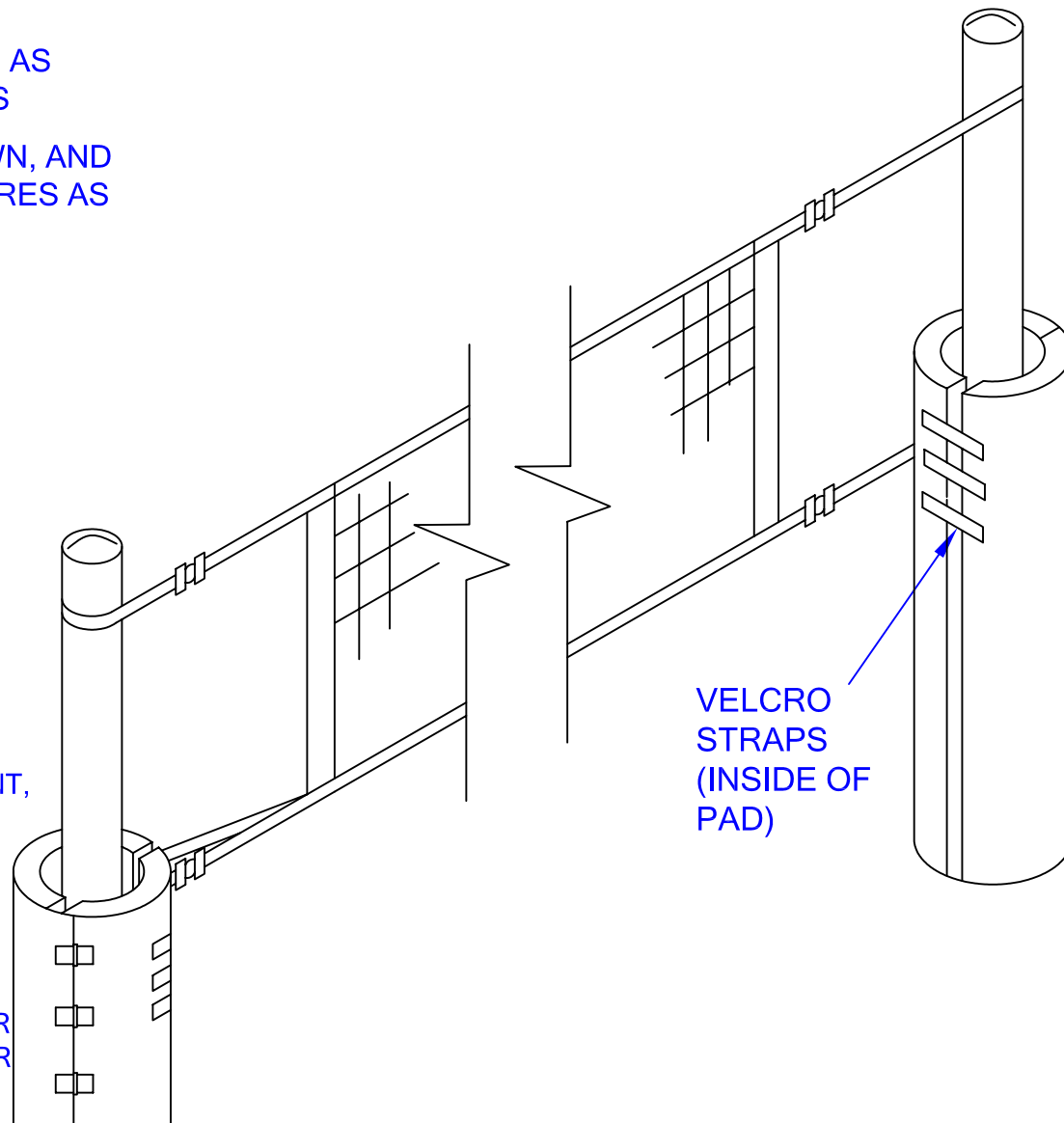

976 HARTFORD TURNPIKE  
WATERFORD, CT 06385 USA  
www.jaypro.com

MODEL NAME: <b>PVB-10P</b>		CHECKED BY: <b>WVB</b>
DESCRIPTION: <b>POWER VOLLEYBALL PAD CUSTOMER INSTALLATION</b>		
DATE: <b>5-6-03</b>	REV <b>-</b>	DRAWN BY: <b>JAC</b>