

1. SET POSTS TO DESIRED HEIGHT.
2. LENGTHEN WINCH STRAP. IT SHOULD SIT AT OR BELOW THE WINCH BEFORE MOVING FORWARD.
3. SHORTEN LENGTH OF ANCHOR STRAP AS MUCH AS POSSIBLE BEFORE BUCKLE REACHES PULLEY.

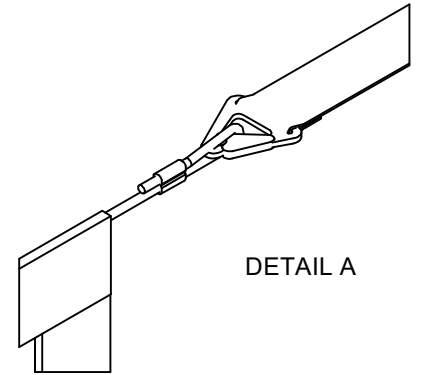

4. CONNECT PRE-MADE LOOP ON TOP CABLE TO ANCHOR END.

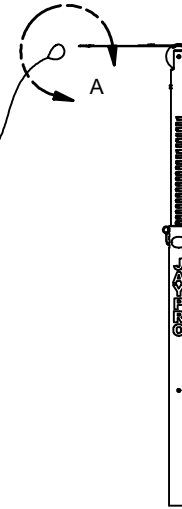
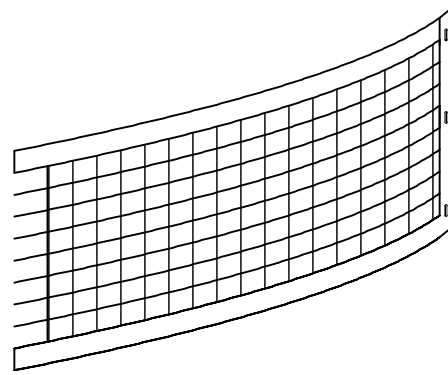

DETAIL A

5. WALK NET ACROSS THE COURT AND BRING OTHER END CLOSE TO WINCH POST.
6. TIE KNOT AT END AS SHOWN TO CREATE A LOOP AND SHORTEN THE TOP CABLE AS MUCH AS POSSIBLE. DO NOT CUT EXCESS ROPE UNTIL SET UP IS COMPLETE.
7. CONNECT THE KNOTTED LOOP TO THE STRAP ON THE WINCH POST.

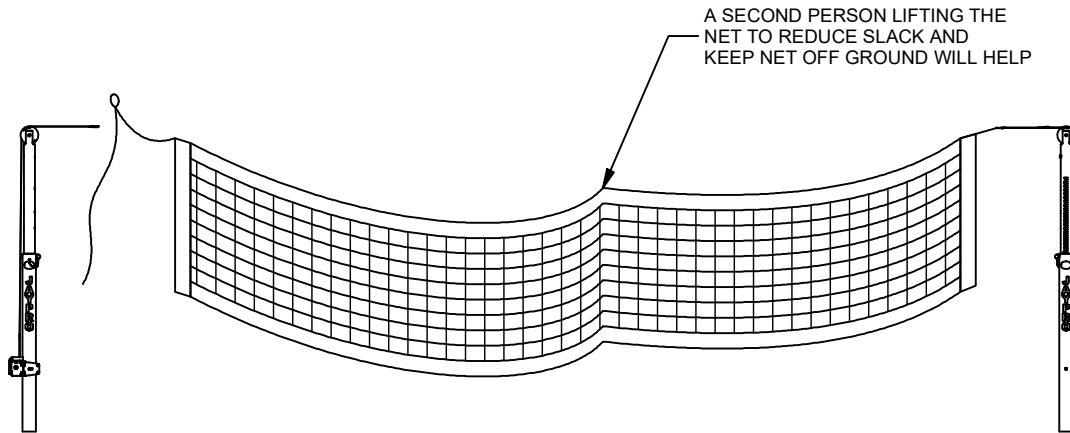

A SECOND PERSON LIFTING THE NET TO REDUCE SLACK AND KEEP NET OFF GROUND WILL HELP

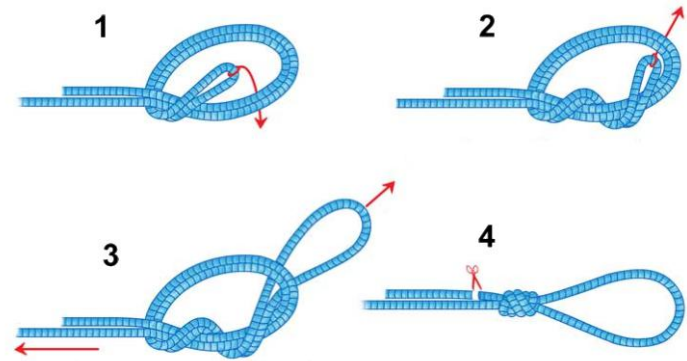

8. CRANK WINCH UNTIL DESIRED TENSION AND NET HEIGHT IS REACHED. IF UNABLE TO REACH DESIRED TENSION BECAUSE BUCKLE ON WINCH STRAP REACHES PULLY, SLIDE NET TO ANCHOR POST AND GO BACK TO STEP 2. LENGTHEN WINCH STRAP MORE AND SHORTEN TOP CABLE BY MOVING KNOT.

9. CENTER NET BY SLIDING IT ON TOP CABLE. IF UNABLE TO MOVE NET TOWARDS WINCH SIDE AS NEEDED, LENGTHEN ANCHOR STRAP AND TIGHTEN WINCH ACCORDINGLY.

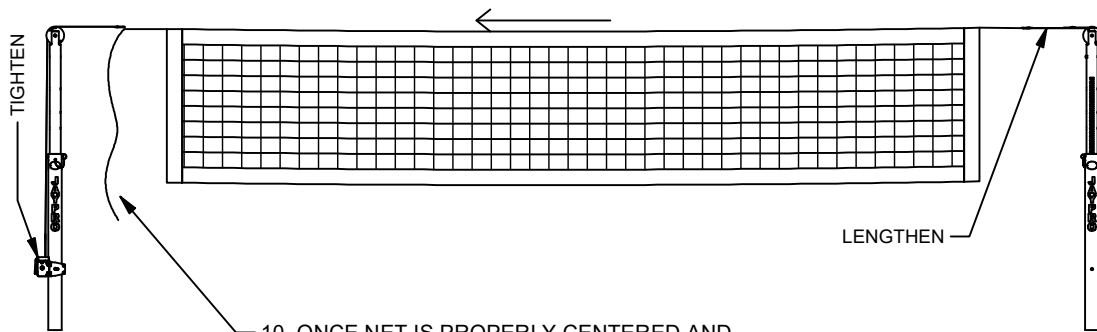

10. ONCE NET IS PROPERLY CENTERED AND TENSIONED, THE EXCESS ROPE MAY BE CUT FROM THE TOP ROPE. WE RECOMMEND LEAVING ~2FT IN CASE FURTHER ADJUSTMENT IS NEEDED IN THE FUTURE

12. CONNECT LOOP TO SNAP HOOK.

13. SEND EXCESS ROPE AROUND POST AND THEN PULL THROUGH CABLE WINCH TO TIGHTEN.

NOTE: CABLE WINCH (P/N HM6638) NOT INCLUDED WITH NET - TO BE INCLUDED WITH SYSTEM HARDWARE.

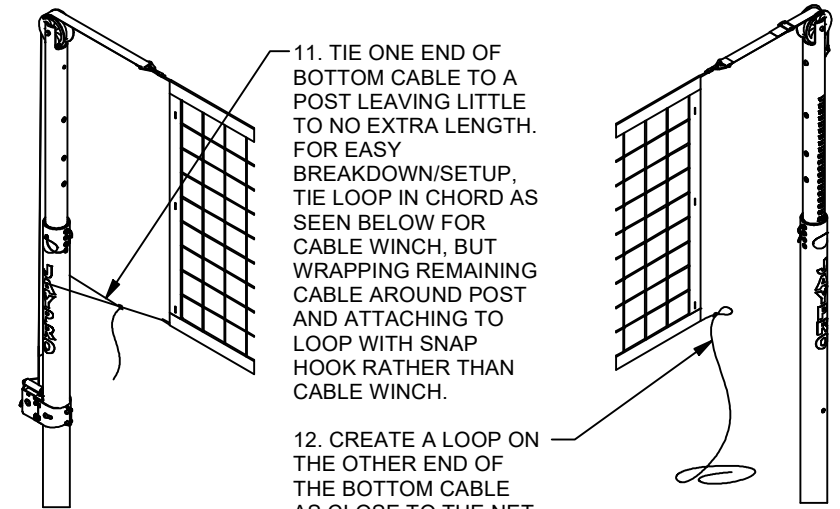
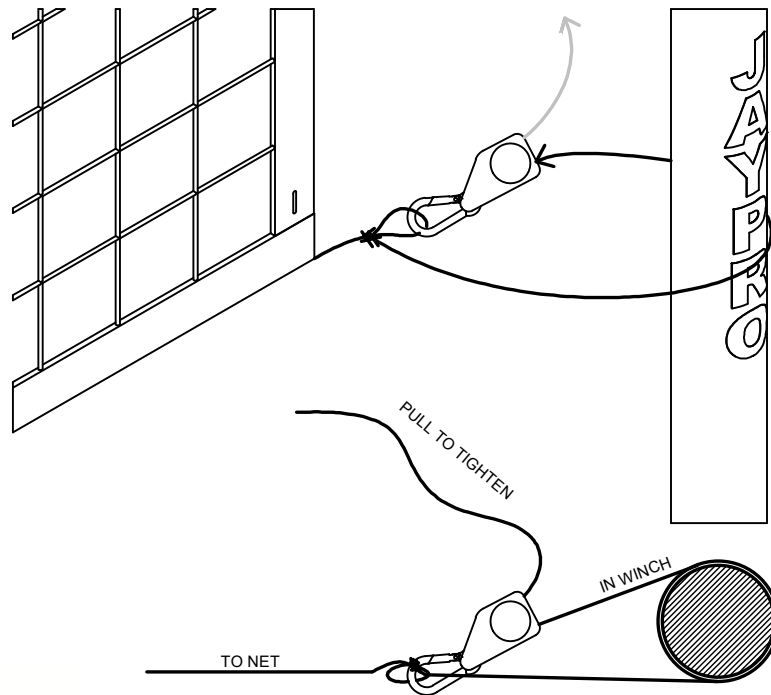

11. TIE ONE END OF BOTTOM CABLE TO A POST LEAVING LITTLE TO NO EXTRA LENGTH. FOR EASY BREAKDOWN/SETUP, TIE LOOP IN CHORD AS SEEN BELOW FOR CABLE WINCH, BUT WRAPPING REMAINING CABLE AROUND POST AND ATTACHING TO LOOP WITH SNAP HOOK RATHER THAN CABLE WINCH.

12. CREATE A LOOP ON THE OTHER END OF THE BOTTOM CABLE AS CLOSE TO THE NET AS POSSIBLE AS DONE PREVIOUSLY ON THE TOP CABLE. LEAVE AS MUCH EXCESS LENGTH AS POSSIBLE.

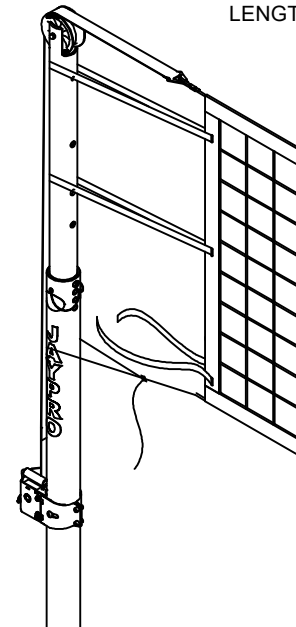

14. INSERT WHITE STRAPS THROUGH OBLONG CUTOUTS AND AROUND UPRIGHT. USE THREE PER POST.

15. PULL TO DESIRED TENSION AND SECURE USING VELCRO.



PVBN-5_INSTALL

www.jayprosports.com / (800) 243-0533 / 976 Hartford Tpke, Waterford, CT 06385 USA

SUBJECT TO CHANGES IN DESIGN AND MANUFACTURING
© COPYRIGHT 2022 JAYPRO SPORTS, LLC. ALL RIGHTS RESERVED