

Seismic Bracket Adapter Kit for Safety Cabinet, No Drill - 84000

Product Images

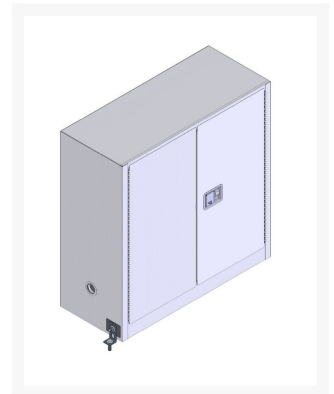

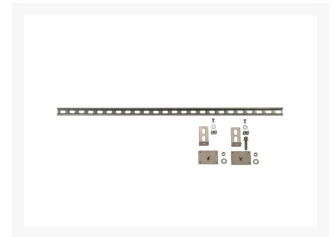
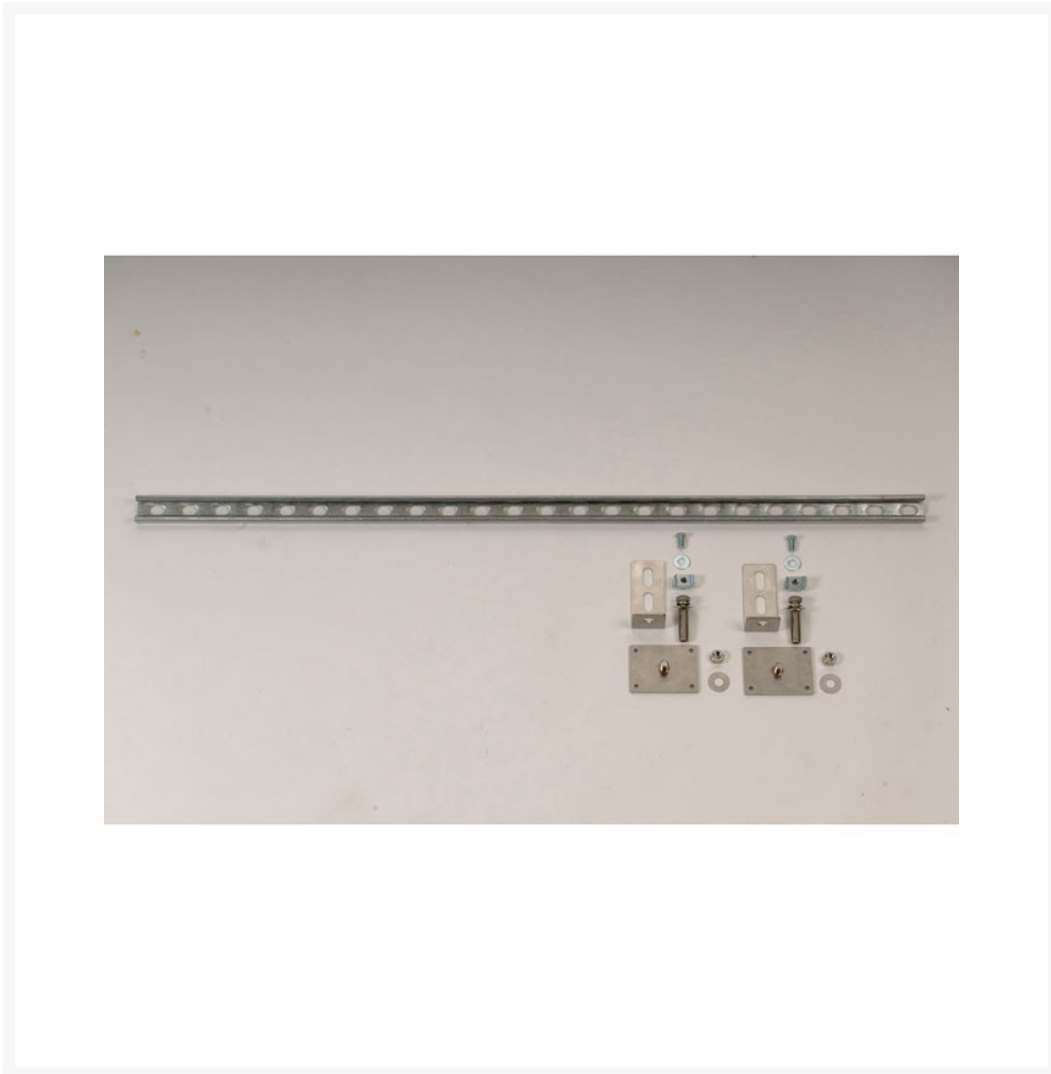

Short Description

Key Benefits

- Ideal for earthquake or hurricane prone areas
- Provides extra security for free standing cabinets

Description

Seismic Bracket Kit provides increased stability—ideal for earthquake or hurricane prone areas. One kit secures any safety cabinet to a wall or floor. Because there are no holes created, the fire protection properties of the cabinet remain intact and the cabinet maintains FM approval.

Specifications

Model No	84000
UPC	697841121546
International Model No.	84000
Material Specifications	Steel
Dimensions, Exterior	4" H x 48" W x 4" D
	102mm H x 1219mm W x 102mm D
Net Weight, lbs	4.2
Net Weight, kg	1.9