

# L23GSH

## Indoor Emergency Safety Shower

### Type: Laboratory, Drench

Wall mounted laboratory shower suitable for laboratories and general light duty indoor use. The powder coated stainless steel pipework ensures resistance to corrosive and flammable materials while being easy to clean.

Meets the requirements of ANSI Z358.1-2014 and the European Standard EN 15154 for plumbed in laboratory showers. Includes universal shower sign for enhanced visibility.



## Specifications

MATERIALS OF CONSTRUCTION	
PIPEWORK AND FITTINGS (GS)	Stainless steel tubulars and fittings
OPERATING VALVE	316L stainless steel, two piece stay open valve
SHOWER SPRAY OUTLET	Powder coated stainless steel shower rose
STANDARD FINISH	Green powder coated finish
SERVICES	
WATER INLET	1 in Male NPT
DESIGN OPERATING PRESSURE	1.5 to 6 BAR G (22 to 87 PSI)
TEST PRESSURE	10.3 BAR G (149 PSI)
MINIMUM FLOW AT OPERATING PRESSURE	Shower: 76 liters/minute minimum (20 US Gallons)
ENVIRONMENTAL OPERATING TEMPERATURE	
MINIMUM AMBIENT OPERATING TEMPERATURE	5° C (41° F)
MAXIMUM AMBIENT OPERATING TEMPERATURE	35° C (95° F)
OPERATIONAL	
SHOWER SPRAY OPERATION	Pull handle
NOMINAL WEIGHTS and DIMENSIONS	
DIMENSIONS - STANDARD ORIENTATION (W x D x H)	319 mm (12.6 in) x 799 mm (31.4 in) x 913 mm (35.9 in) Height includes sign
WEIGHT (NO OPTIONS)	5 kg (11 lb)

# HUGHES



Justrite Safety Group

RM07302 RevA

[hughes-safety-showers.com](http://hughes-safety-showers.com)

Indoor Emergency Safety Shower Type: Laboratory, Drench

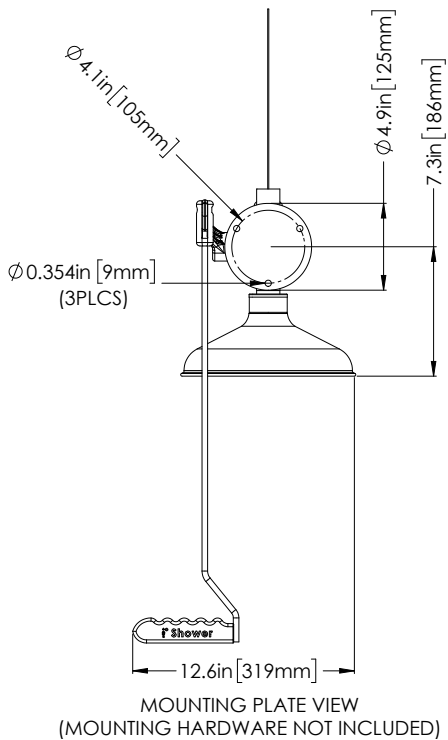
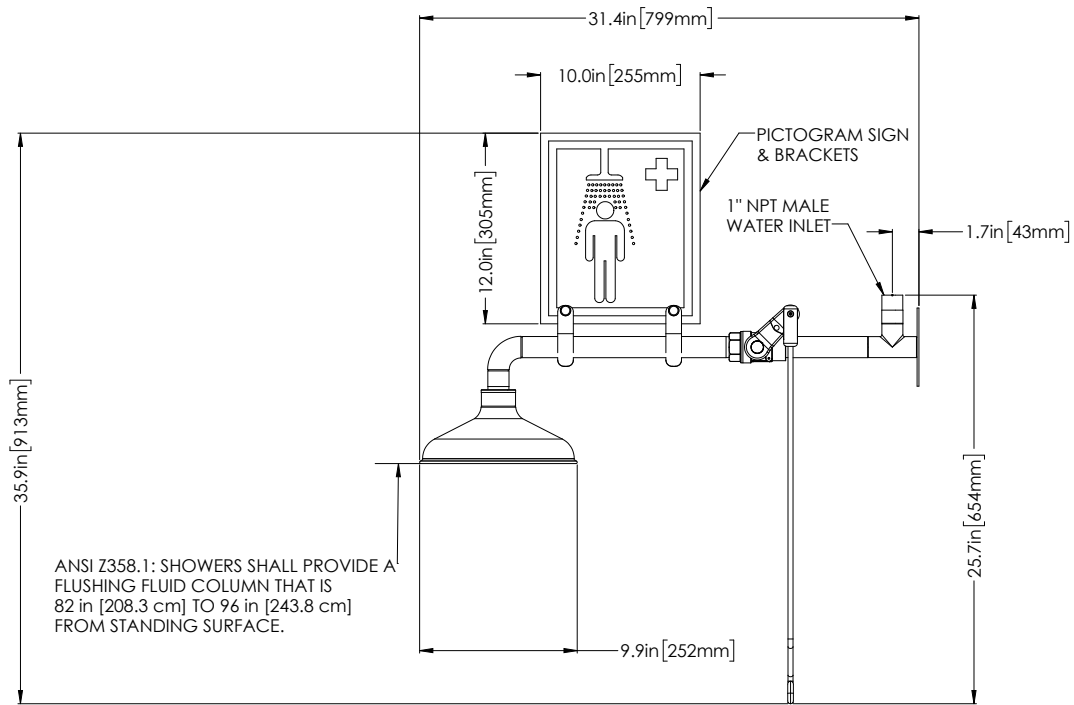

VARIATIONS IN MANUFACTURING AND ASSEMBLY ALLOW FOR ±1/8 in [3 mm] PER THREADED JOINT.

For Technical Support Contact:  
customer.service@hughes-safety.com • 1-866-312-1652

For Reorder & Sales Support Contact:  
custserv@justrite.com • 1-800-798-9250

**HUGHES**

HUGHES-SAFETY-SHOWERS.COM  
Justrite Safety Group

Hughes North America  
457 Campbell Street  
Sarnia, Ontario N7T 2J1, Canada.

Registered No. 0939240. VAT Registration No. 918 5005 32 ©2019 Hughes Safety Showers