

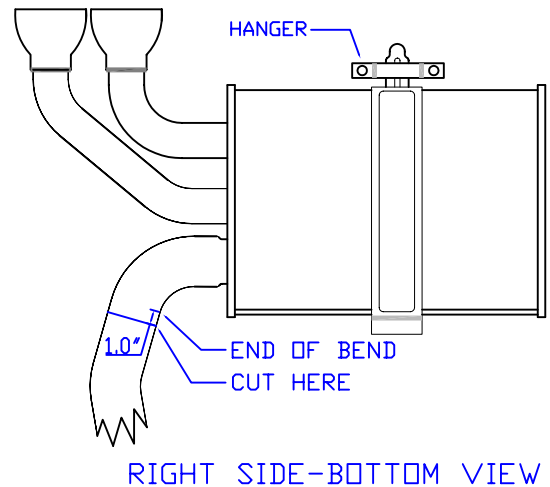

Installation diagram for:
SYSTEM #525802 – L/R
1997-2004 C5 CORVETTE



12/11/09

Removal:

- 1) Raise the vehicle up on a hoist or rack to working height. If you do not have access to a hoist or rack raise the vehicle and support securely with jack stands.
- 2) Using a hacksaw or sawsall, cut the stock muffler inlet pipes as shown in the diagram. (If you are using the optional Flowmaster inlet pipe kit P/N1030, this step is not necessary.)
- 3) Using a 13mm socket and extension, remove the two nuts that secure the rubber hanger to the frame. This will allow the muffler to be removed from the car.

Installation:

- 1) Before installing anything, prep the clamps supplied in the hardware kit by removing the nuts, and applying a thick lubricant such as white grease or anti-seize to the threads.
- 2) Slide the rubber hangers off of the stock mufflers and onto the bracket located on the Flowmaster muffler.
- 3) Raise the muffler up into position and slide onto the factory over-axle pipe. Rotate the muffler up so that the rubber hanger fits into place over the studs. Install the two nuts and tighten securely.
- 4) Repeat these steps for the opposite side muffler.
- 5) Adjust the position of all mufflers to provide a satisfactory fit before installing the supplied muffler clamps and tightening securely. The clamps should be placed with the saddles oriented to minimize visibility.
- 6) For a cleaner appearance and more secure installation, we highly recommend welding all slip-fit connections. If you live in a geographical area that has harsh winters or sees a great deal of precipitation, the use of high temperature paint over the welded areas can help to prevent surface rust and premature corrosion.