



LIQUIDYNAMICS™

HOSE REEL

Instruction & Parts Manual

**Open Reel Models 43002, 43002DEF,
43003 and 43102
Enclosed Reel Models 44002 and 44102**



**Model 43002,
43002DEF & 43102**



Model 44002 & 44102

This manual contains important warnings and information. READ AND KEEP FOR REFERENCE.

2311 S. Edwards • Wichita, KS 67213
TEL: 316-943-5477 • FAX: 316-943-4760
TOLL FREE: 800-894-3572
E-MAIL: productinfo@liquidynamics.com

WARNING

This symbol indicates a potentially hazardous situation which, if not avoided, could result in death or serious injury.

CAUTION

This symbol indicates a potentially hazardous situation which, if not avoided, may result in injury or damage to equipment.

Introduction:

These hose reels are a practical, safe, reliable and economical way to extend the useful life of hoses, maintain a safe and clean environment and significantly improve Service Technician efficiency. Typical applications are for use with air, water, engine and gear oils, hydraulic and transmission fluids, antifreeze and greases.

WARNING

Use these reels only for the purpose for which they have been designed. Do not exceed working pressure of reel or hose. Do not use these reels for flammable, explosive or corrosive applications. Do not modify any components and use only original spare parts.

WARNING

If this reel was provided without hose, install hose designed specifically for the purpose for which the reel was designed and follow the original manufacturers specifications for hose requirements. Use only hose rated at or above the working pressure indicated.

Note:

Liquidynamics will not accept responsibility for any liability or damages resulting from the use of this product or malfunction associated with hoses not installed by Liquidynamics.

CAUTION

Insure that incoming line pressure does not exceed rated operating pressure of your model hose reel. Refer to technical specifications on page 6 for pressure ratings.

CAUTION

To avoid damage to the reel, control handle or meter, always hold onto hose while it is rewinding.

Before Installation:

1. Make sure mounting surface is sturdy enough to hold the weight of the hose reel and take the stress of use. If wall mounting, check both the inside and outside of wall to make sure no electrical or plumbing lines will interfere with installation.

2. It is recommended to install a supply line shut-off valve just before the connection hose between product supply line and reel, fig. 1. This allows easy maintenance of reel, hose and control valve or meter.

3. Hose reel mounting channel kits and product service labels (fig. 2) are available for ease of installation. Consult your Liquidynamics catalog or call 800-894-3572 for specific recommendations and part numbers.

4. Flush product supply lines with generous quantities of product in order to remove air, loose dirt, scale, shavings, etc. This will prevent damage to reels, meters and control valves.

5. Determine desired orientation of reel to best fit your specific installation. Reels are shipped with guide arm in position shown in fig. 3.

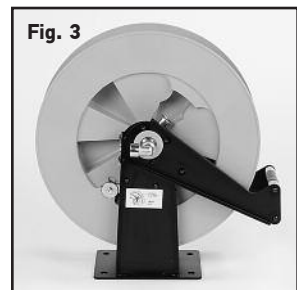
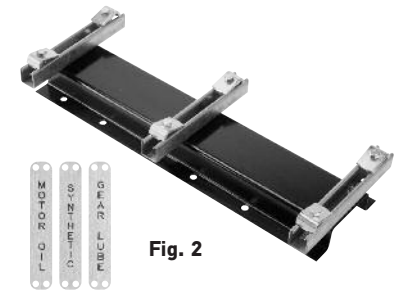
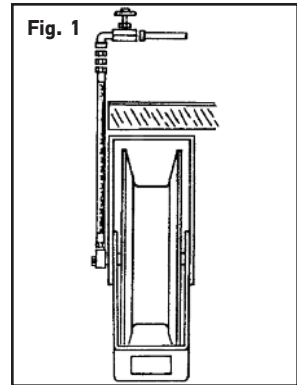

Note: Hose reels may be installed on ceiling to a maximum height of 15'.

Reels may be mounted on ceiling, wall or tank (floor) as shown in fig. 4a, 4b, 4c and 4d. Refer to instructions that follow to reposition guide arm.

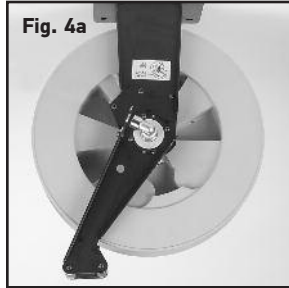

Ceiling mount

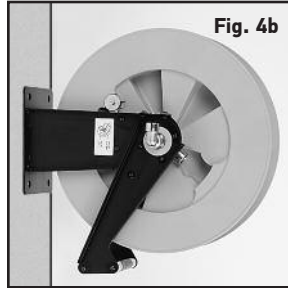

Wall mount

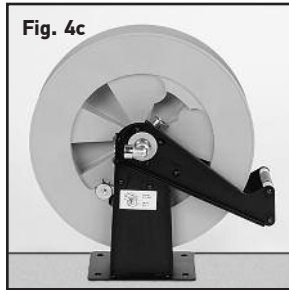

Floor, tank mount,
bottom discharge

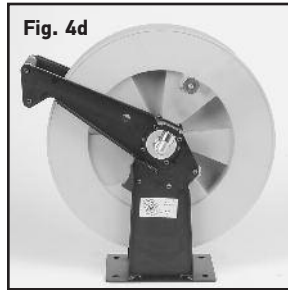

Floor, tank mount,
top discharge

Hose Guide Re-Orientation – Open Reels

Depending on the location of reel installation, it may be necessary or desirable to change the orientation of the hose guide arm as supplied from Liquidy-namics, fig. 5c. This is easily accomplished as follows:



Floor, tank mount,
top discharge

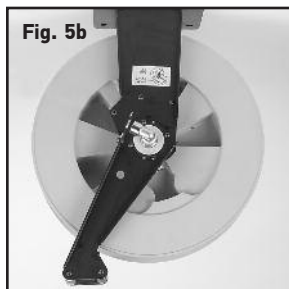

Ceiling mount

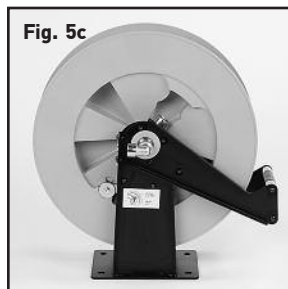

Floor, tank mount,
bottom discharge

Note: It is not necessary to relieve spring tension when repositioning the guide arm. Follow directions below to re-position guide arm without relieving spring tension.

1. Latch drum by pulling out hose until latch key engages, thus preventing reel retraction.

2. While drum is latched, loosen and remove (2 ea.) 4 mm Allen screws on each side of hub, screws "A" and "B", fig. 6a and 6b.

CAUTION

Do not remove all four Allen screws on either side of reel, at once, this will cause spring tension to be relieved suddenly, possibly causing reel damage.

3. Loosen screws "C" and "D" on both sides of hub just enough to allow hose guide arm (fig. 6a & fig. 6b) to be repositioned as shown in fig. 5b. It may be necessary to slightly pull the guide arm toward swivel side of reel in order to clear screw, item "E", fig. 6a.

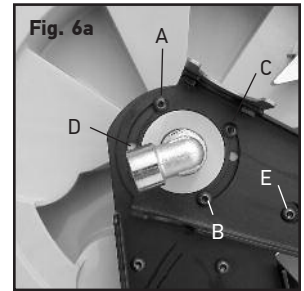

4. Tighten screws "C" and "D" (fig. 6a and 6b) to secure guide arm in ceiling mount position, fig. 5b. Reinstall and tighten screws "A" and "B" (fig. 6a and 6b). If it is desired to position guide arm to top discharge position, fig. 5a, skip to instruction #6 below.

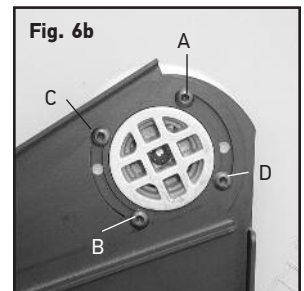

5. Pull hose to release latch spring. Hose reel is now ready for ceiling mount use.

6. With hose still in latched position, loosen and remove screws "C" and "D" on both sides of reel hub.

7. Slightly loosen screw "A" and "B" to allow guide arm to be repositioned to position shown in fig. 5a (top discharge tank or floor mount).

8. Tighten screws "A" and "B" and reinstall screws "C" and "D", fig. 6a and 6b, on both sides of reel hub.

9. Pull hose to release latch spring. Hose reel is now ready for top discharge, tank or floor mounting use.

Note: Hose length protruding from reel may be adjusted by relocating the ball stop shown in fig. 7. To relocate ball stop, loosen 2 each, 4mm Allen screws "A" and move ball stop to desired location and retighten Allen screws.

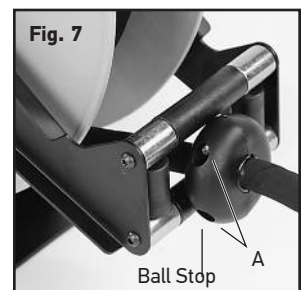

Hose Guide Re-Orientation – Enclosed Reels

Note: The enclosed reel hose orientation may be easily changed without relieving spring tension.

1. Remove 4 ea. (4 mm) Allen screws (C) holding mounting bracket to reel case (fig. 8a).

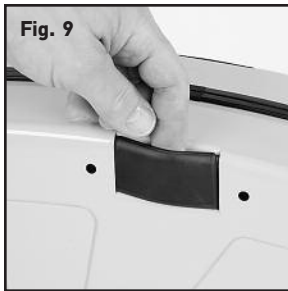
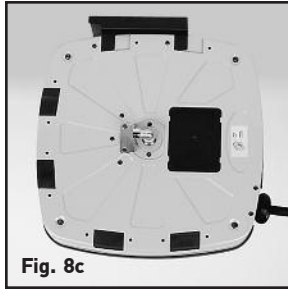
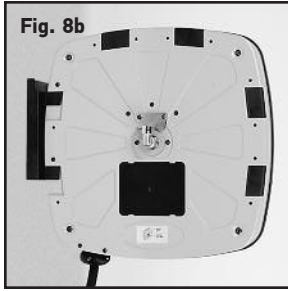
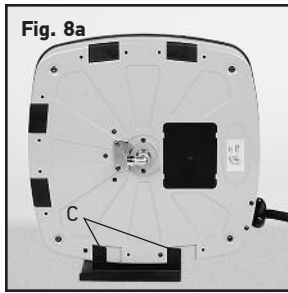

2. Remove 4 ea. black rubber plugs at desired location for bracket, fig. 9.

3. Reattach mounting bracket at desired location, position b or c, fig. 8.

4. Insert 4 ea. black rubber plugs into vacated position, fig. 10.

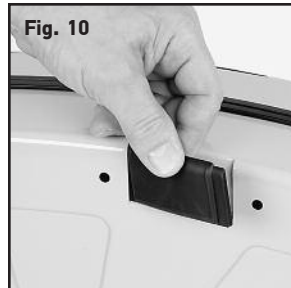

Note: Hose reels may be installed on ceiling to a maximum height of 15'.

Connecting (Jumper) Hose

Note: Use an appropriately rated thread sealant such as Loctite® 545 on all hose connections to ensure a leak free connection.

Liquidynamics hose reels are provided with a two foot connecting hose. Attach rigid end of hose to inlet swivel of hose reel, fig. 11. Ensure that connecting hose is routed through “keeper” as shown, fig. 11b. This reduces tension and wear on reel swivel thus ensuring maximum swivel life.

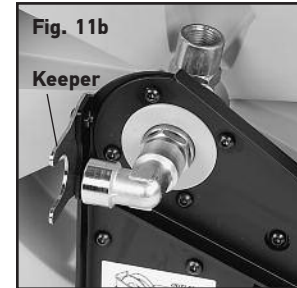
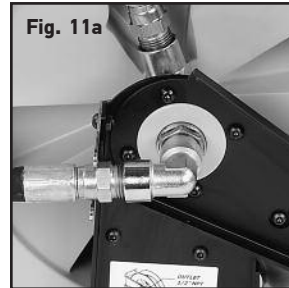

Installing Hose – Open Reels

1. Insert hose end with swivel connector through roller hose guide and attach to hose reel outlet adapter, fig. 12a and 12b.

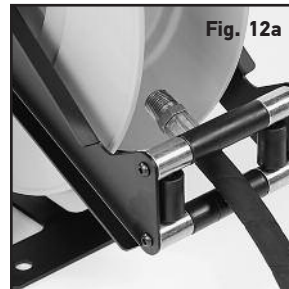

2. Wind hose onto reel by turning hose drum clockwise (viewed from swivel side) until full length of hose is threaded onto drum.

3. Tension spring by turning drum with hose a full 5 turns counterclockwise (viewed from swivel side). Thread end of hose through roller hose guide and attach ball stop at desired position on hose, fig. 13

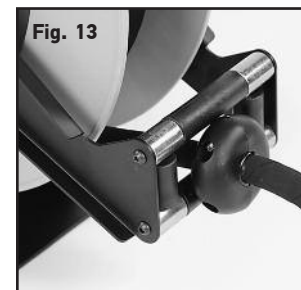

Installing Hose – Enclosed Reels

Note: Use an appropriately rated thread sealant such as Loctite® 545 to ensure a leak free connection.

1. Remove access cover on swivel side of reel, fig. 14.
2. Insert hose end with swivel connector through roller hose guide and attach hose to reel outlet adapter, fig. 15. Note: Drum must be rotated to proper position to gain access to outlet adapter, fig. 15.
3. Wind hose onto reel by turning drum clockwise by hand through the access port, leaving desired length of hose protruding from reel, fig. 16.

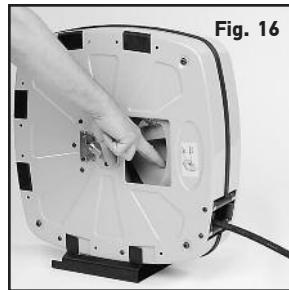
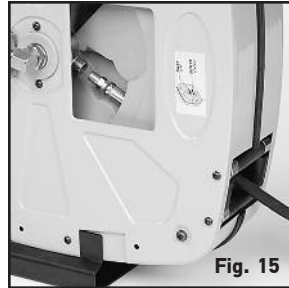

4. Attach ball stop at desired location, fig. 17.

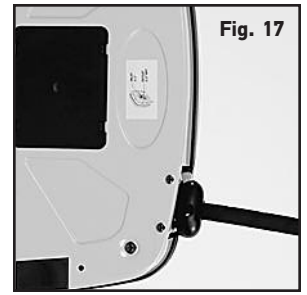

5. Tension spring by first removing the two (4 mm) Allen screws (D) attaching the hub to the case, fig. 18. Insert a 1/2" socket driver into receptacle at center of hub, turn hub a full 5 turns counterclockwise, fig. 19. While holding hub tension reinstall the two (4 mm) Allen screws to secure the hub to the case.

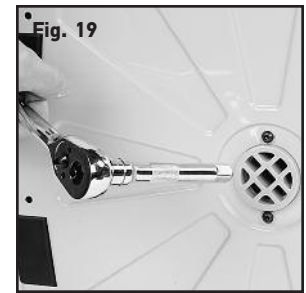
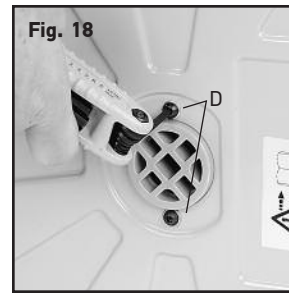

Overall Dimensions:

Mounting Pattern

Common to all reels

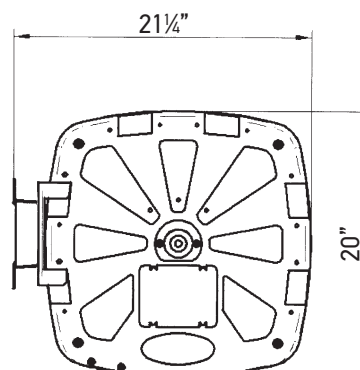
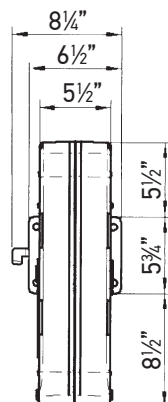
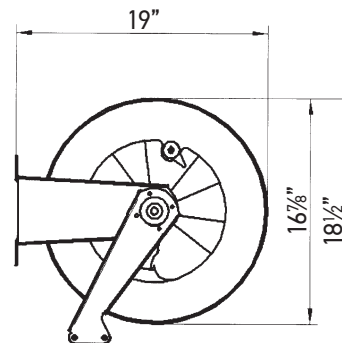
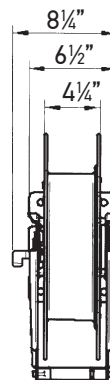
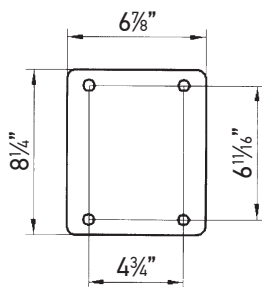

Technical Specifications:

	MODEL	Working Pressure	Hose Length	Hose Dia. I.D.	Inlet Connection	Outlet Connection	Maximum Winding Capacity				Shipping Weight	
							1/4"	3/8"	1/2"	3/4"		
OPEN REELS	AIR/WATER	43002	1,160 PSI	—	—	1/2" NPTF	1/2" NPTF	—	60 ft.	—	—	28
		43002-30A	250 PSI	30 ft.	3/8"	1/2" NPTF	1/2" NPTM	—	—	—	—	34
		43002-50A	250 PSI	50 ft.	3/8"	1/2" NPTF	1/2" NPTM	—	—	—	—	37
	OIL	43002	1,160 PSI	—	—	1/2" NPTF	1/2" NPTF	—	60 ft.	50 ft.	—	28
		43002-25L	1,160 PSI	25 ft.	1/2"	1/2" NPTF	1/2" NPTM	—	—	—	—	37
		43002-30L	1,160 PSI	30 ft.	1/2"	1/2" NPTF	1/2" NPTM	—	—	—	—	38
		43002-40L	1,160 PSI	40 ft.	1/2"	1/2" NPTF	1/2" NPTM	—	—	—	—	40
		43002-50L	1,160 PSI	50 ft.	1/2"	1/2" NPTF	1/2" NPTM	—	—	—	—	43
	DEF	43002DEF	210 PSI	—	—	3/4" NPTF	3/4" NPTF	—	—	—	25 ft.	28
		43002DEF-25	210 PSI	25 ft.	3/4"	3/4" NPTF	3/4" NPTF	—	—	—	—	34
	GREASE	43102	8,700 PSI	—	—	1/4" NPTF	1/2" NPTF	60 ft.	60 ft.	—	—	28
		43102-30G	8,700 PSI	30 ft.	1/4"	1/4" NPTF	1/4" NPTM	—	—	—	—	35
		43102-50G	8,700 PSI	50 ft.	1/4"	1/4" NPTF	1/4" NPTM	—	—	—	—	40
		43103-30G	8,700 PSI	30 ft.	3/8"	1/4" NPTF	1/4" NPTM	—	—	—	—	40
		43103-50G	8,700 PSI	50 ft.	3/8"	1/4" NPTF	1/4" NPTM	—	—	—	—	45

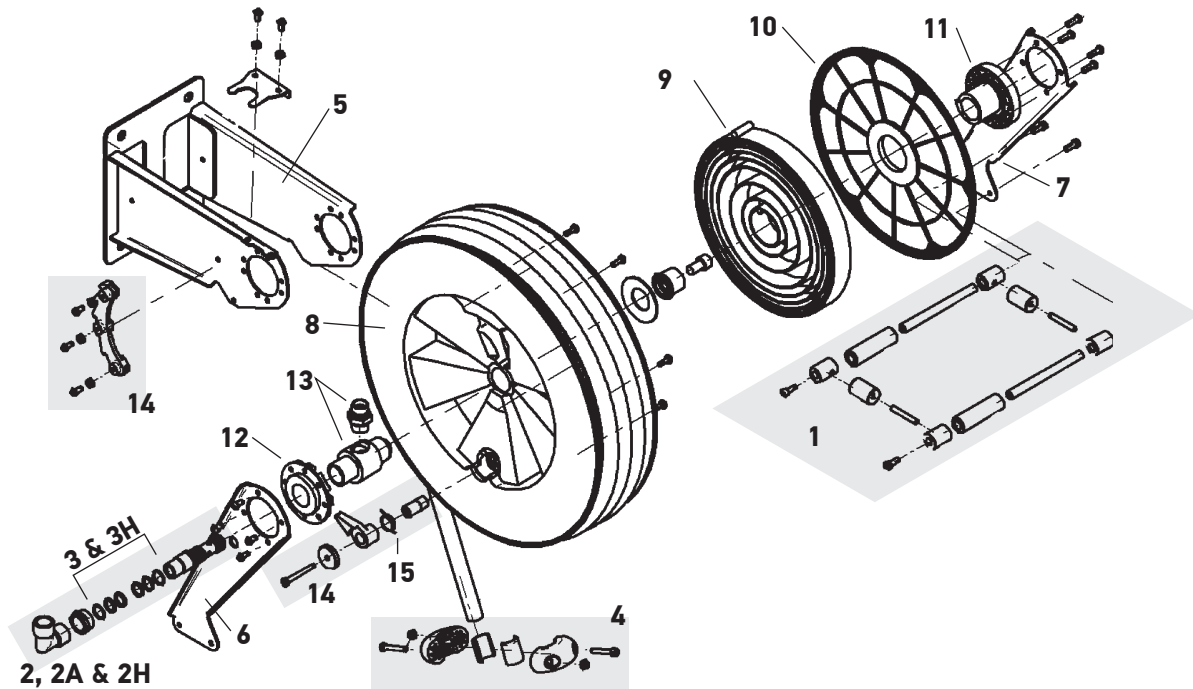

Exploded Parts Items – Models 43002, 43002DEF and 43102:

1	S45001	Hose guide kit	7	S45010	Guide arm, right
2	S45006	Swivel kit, medium pressure, oil	8	S45011	Hose drum
2A	S45006DEF	Swivel inlet assy. for 43002DEF	9	S45012	Spring
2H	S45003	Swivel kit, high pressure, grease	10	S45013	Spring cover
3	S45051	Seal kit, medium pressure	11	S45014	Bearing mount, right
3H	S45005	Seal kit, high pressure, grease	12	S45015	Bearing mount, left
4	S45007	Hose stop kit	13	S45016	Hub kit
5	S45008	Pedestal mount	14	S45017	Ratchet/pawl kit
6	S45009	Guide arm, left	15	S45018	Spring, Ratchet/pawl

Technical Specifications:

MODEL		Working Pressure	Hose Length	Hose Dia. I.D.	Inlet Connection	Outlet Connection	Maximum 1/4"	Winding Capacity 3/8"	1/2"	Shipping Weight	
ENCLOSED REELS	AIR/WATER	44002	1,160 PSI	—	—	1/2" NPTF	1/2" NPTF	—	60 ft.	—	39
		44002-30A	250 PSI	30 ft.	3/8"	1/2" NPTF	1/2" NPTM	—	—	—	46
		44002-50A	250 PSI	50 ft.	3/8"	1/2" NPTF	1/2" NPTM	—	—	—	49
	OIL	44002	1,160 PSI	—	—	1/2" NPTF	1/2" NPTF	—	60 ft.	50 ft.	38
		44002-25L	1,160 PSI	25 ft.	1/2"	1/2" NPTF	1/2" NPTM	—	—	—	47
		44002-30L	1,160 PSI	30 ft.	1/2"	1/2" NPTF	1/2" NPTM	—	—	—	48
		44002-40L	1,160 PSI	40 ft.	1/2"	1/2" NPTF	1/2" NPTM	—	—	—	51
		44002-50L	1,160 PSI	50 ft.	1/2"	1/2" NPTF	1/2" NPTM	—	—	—	52
	GREASE	44102	8,700 PSI	—	—	1/4" NPTF	1/2" NPTF	60 ft.	60 ft.	—	39
		44102-30G	8,700 PSI	30 ft.	1/4"	1/4" NPTF	1/4" NPTM	—	—	—	47
		44102-50G	8,700 PSI	50 ft.	1/4"	1/4" NPTF	1/4" NPTM	—	—	—	52
		44103-30G	8,700 PSI	30 ft.	3/8"	1/4" NPTF	1/4" NPTM	—	—	—	52
		44103-50G	8,700 PSI	50 ft.	3/8"	1/4" NPTF	1/4" NPTM	—	—	—	57

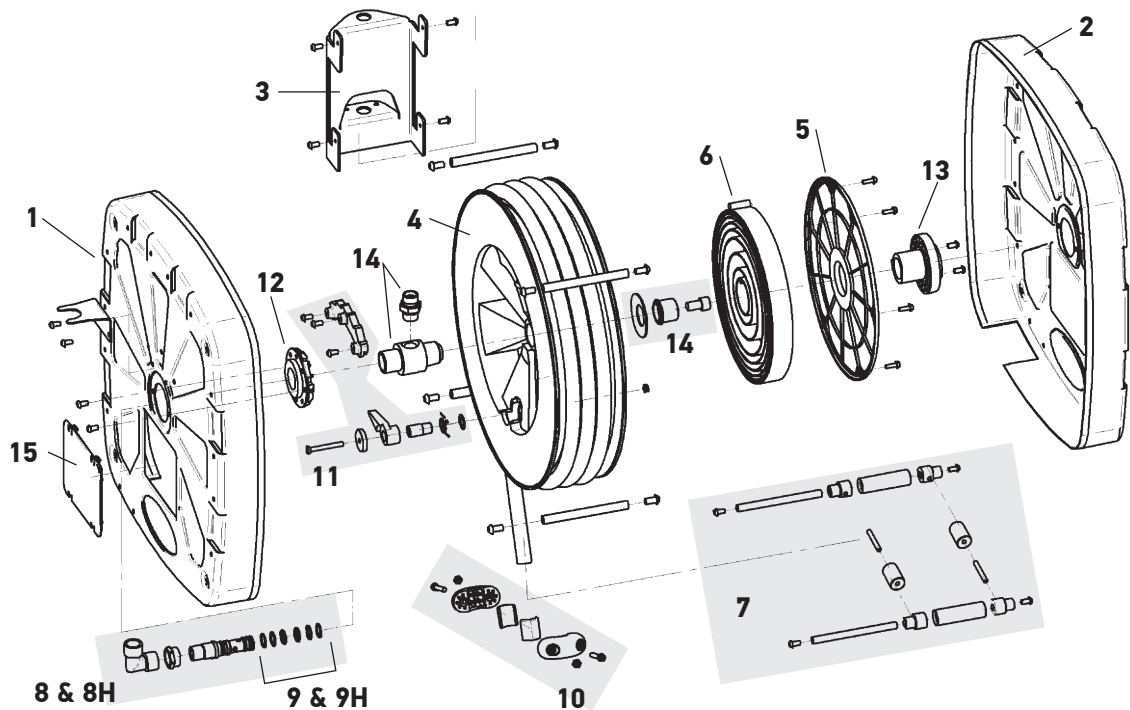

Exploded Parts Items – Models 44002 and 44102:

1	S45030	Left enclosure	9	S45051	Seal kit, medium pressure, oil
2	S45031	Right enclosure	9H	S45005	Seal kit, high pressure, grease
3	S45032	Mounting bracket	10	S45007	Hose stop kit
4	S45011	Hose drum	11	S45017	Ratchet/pawl kit
5	S45013	Spring cover	12	S45015	Bearing mount, left
6	S45012	Spring	13	S45014	Bearing mount, right
7	S45034	Hose guide kit	14	S45016	Hub kit
8	S45006	Swivel kit, medium pressure, oil	15	S45035	Access cover
8H	S45003	Swivel kit, high pressure, grease	16	S45036	Mounting plugs, kit of 6 pcs.

Technical Specifications:

MODEL	Working Pressure	Hose Length	Hose Dia. I.D.	Inlet Connection	Outlet Connection	Max. Winding Capacity	
						3/8"	1/2"
43003	1,160 PSI	—	—	1/2" NPTF	3/8" NPTF	—	—
43003-30A	250 PSI	30 ft.	3/8"	1/2" NPTM	3/8" NPTM	—	—
43003-25L	1,160 PSI	25 ft.	1/2"	1/2" NPTM	1/2" NPTM	—	—

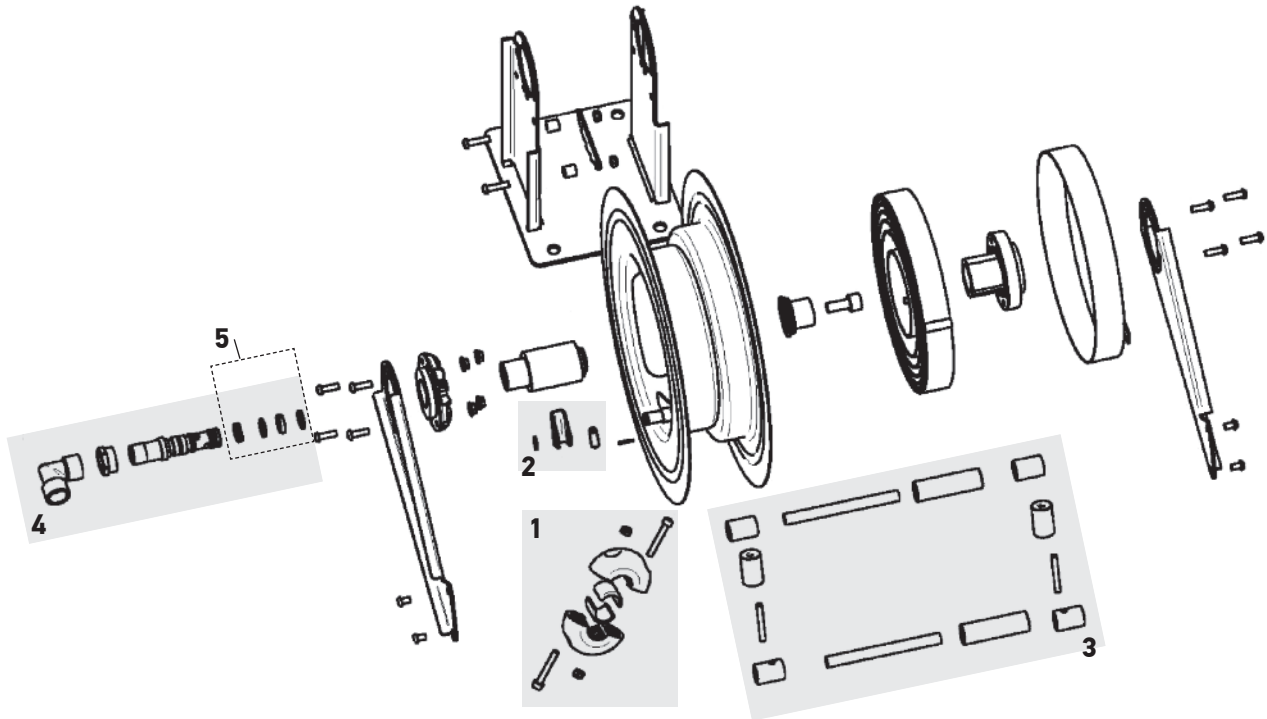

Exploded Parts Items – Model 43003 Hose Reel (Oil, Water and Air Use):

1.	S45007	Hose Stop Kit
2.	S45019	Pawl & Spring Kit
3.	S45020	Hose Guide Kit
4.	S45021	Swivel & Seal Kit
5.	S45022	Seal Kit

Overall Dimensions:

Mounting Pattern

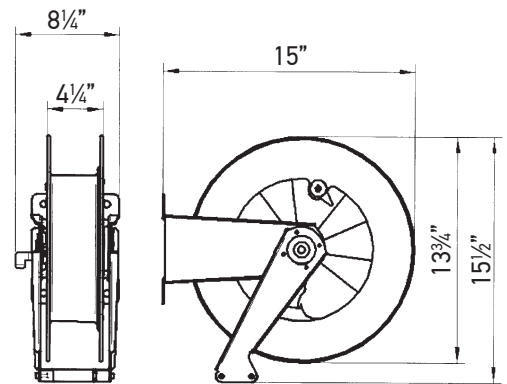
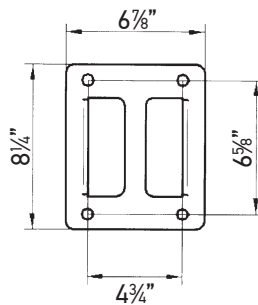

LIQUID DYNAMICS™

2311 S. Edwards • Wichita, KS 67213 / TEL: 316-943-5477 • FAX: 316-943-4760 / TOLL FREE: 800-894-3572

E-MAIL: productinfo@liquidynamics.com / WEBSITE: www.liquidynamics.com