

XLC11-B

Two-Shelf Heavy-Duty Utility Cart

Product Specifications

Item Number	XLC11-B
Material	Injection Molded Thermoplastic Resin Legs: Polyvinyl Chloride (PVC) Shelves: High Density Polyethylene (HDPE)
Color Options	Black
Cart Dimensions	24.5" W x 45.5" L x 33" H
Product Weight	37.8 lbs.
Shelf Quantity	2
Shelf Dimensions	37" L x 24.5" W
Shelf Depth	2.5"
Distance Between Shelves	22.5"
Casters	Two options: • 5" Heavy-Duty • 5" Semi-Pneumatic
Weight Capacity	500 lbs.
Made in USA	Yes
Shipping Method	Ground
Shipping Carton Dimensions	25" W x 45" D x 8" H
Shipping Weight	46 lbs.
Assembly Required	Yes
Meets ANSI/BIFMA Standards	Yes

To Order, Call Your
Sales Representative
or 800-323-4656

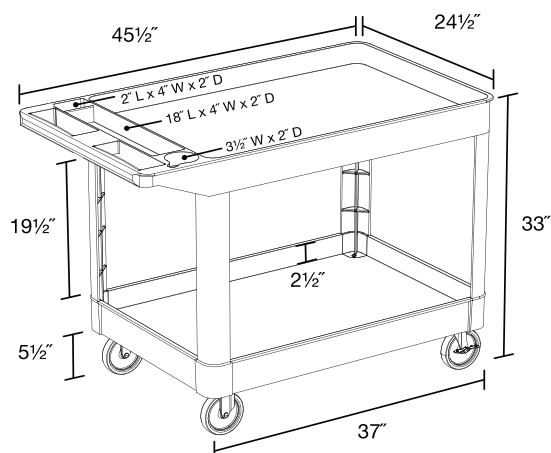

Reinforced ribbing is molded into both shelves for extra strength.

2245 Delany Road, Waukegan, IL 60087
800-323-4656 | Fax 847-244-1818 | www.LuxorFurn.com

LUXOR

INNOVATIVE WORKSPACE PRODUCT SOLUTIONS