

# Locker Options – 77000 Series

## Installation Instructions

Thank you for selecting Salsbury's options for standard lockers. We are confident that the quality and construction of the optional items will prove to be a good investment. These instructions are intended to assist you in assembling various optional items onto the lockers. The items are separate options and may or may not be included with your order.

### Name Plates

The name plates are installed with two (2) #4 slotless screws and nuts.

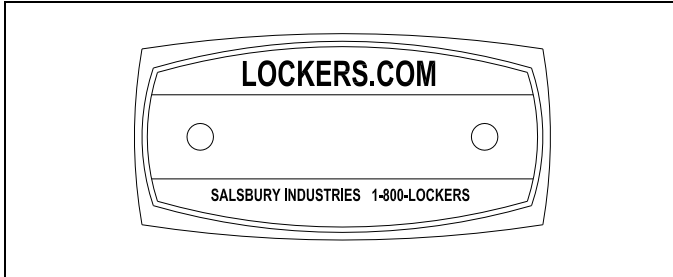

### Sloping Hoods

The sloping hoods are assembled with ten (10) #10 x 3/8" slotless screws and nuts. The side plates should be installed over the flanges of the sloping panel.

The four tapped holes in the bottom of the sloping hood assembly align with holes preexisting in the top panel of the locker assembly. Use four (4) slotted #8 screws installed from the inside of the locker to attach the sloping hood.

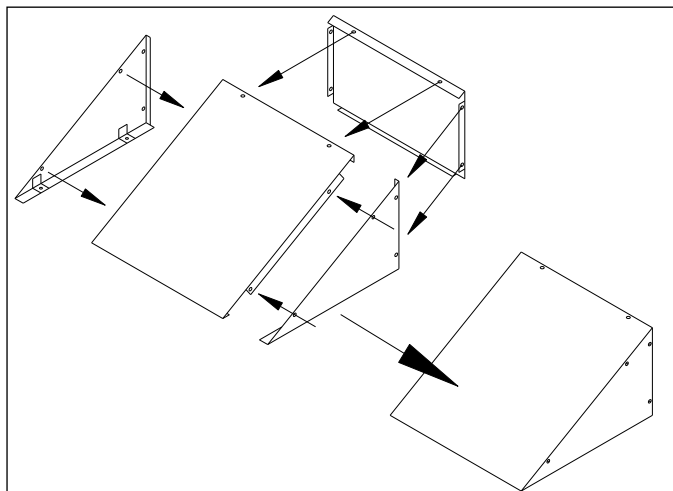

### Front Bases and End Bases

The front bases are installed and fastened with two (2) screws and nuts on each side such that the front base is placed between the two front legs of the locker.

The end bases (universal) are installed and fastened with two (2) screws and nuts such that the end base front edge is placed and fastened behind the locker front leg with the end base rear flanges fastened outside of the locker rear leg.

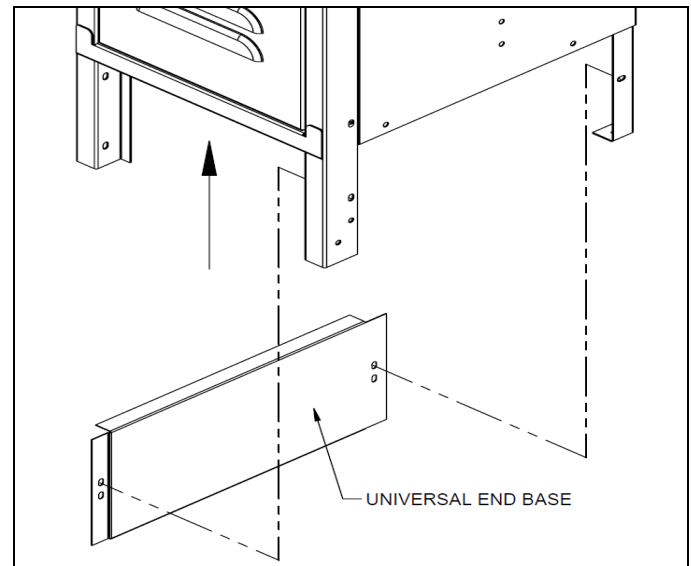
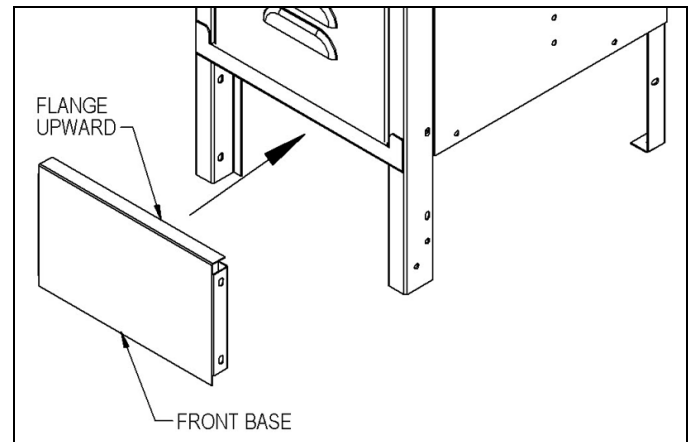

### SALSBURY INDUSTRIES

18300 Central Avenue, Carson, CA 90746-4008  
Phone: 1-800-562-5377 Int'l Phone: 323-846-6700  
Fax: 1-800-562-5399 Int'l Fax: 323-846-6800  
www.lockers.com engineering@lockers.com

# Locker Options – 77000 Series

## Installation Instructions

### Lockers Installation Order with Fillers

Generally, the installation of lockers should start with the corners where locker rows come together at a right angle. After installing the top corner fillers, build the rows outward from the corners incorporating gaps and front vertical fillers where needed. Lastly, install the top in-line fillers. Locker fillers may be cut to special sizes for custom installations.

### Top Fillers – Corners

Top corner fillers are used where two (2) lockers come together in a right angle in a corner. The flat top corner filler and the sloping hood corner filler attach in the same manner. After aligning the two (2) lockers, place the corner filler on the top of the lockers as shown in the illustration. Attach the fillers with six (6) #8 TEK self-drilling screws through the existing holes in the top corner filler.

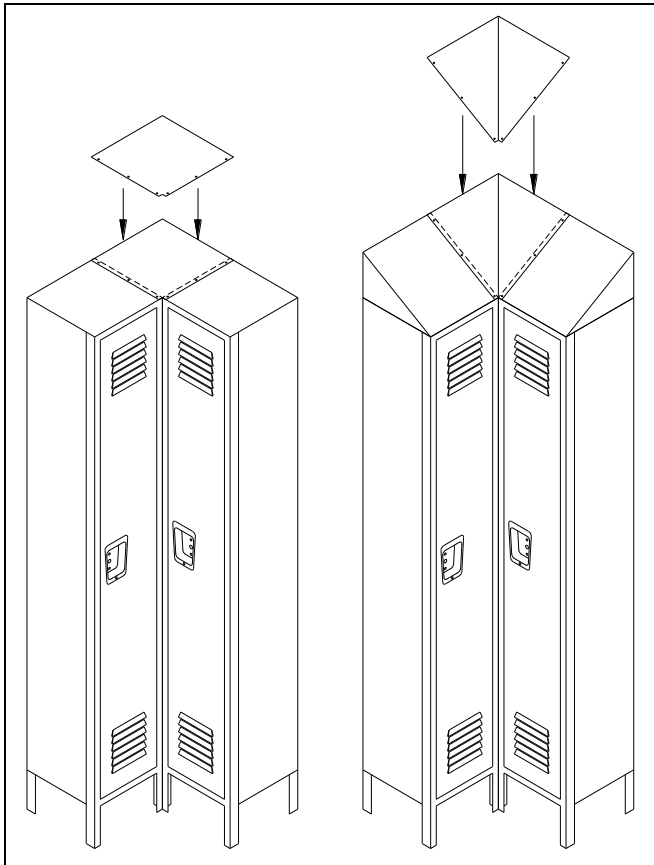

### Front Fillers - Vertical

Vertical front fillers are used where a gap occurs in the row of in-line lockers. The vertical front filler attaches in the same manner in both the flat top lockers and the sloping hood lockers. Cut the wide front filler panel to the appropriate width, if necessary, for the size of the gap between lockers. Align the front filler panel against the side of one locker at the front vertical corner and the angle slip joint against the side of the other locker at its front vertical corner. Attach each of the two (2) pieces with #8 TEK self-drilling screws through the holes provided in the vertical front filler pieces. One of the two lockers is then moved into place while guiding the vertical edge of the wide filler panel into the angle slip joint.

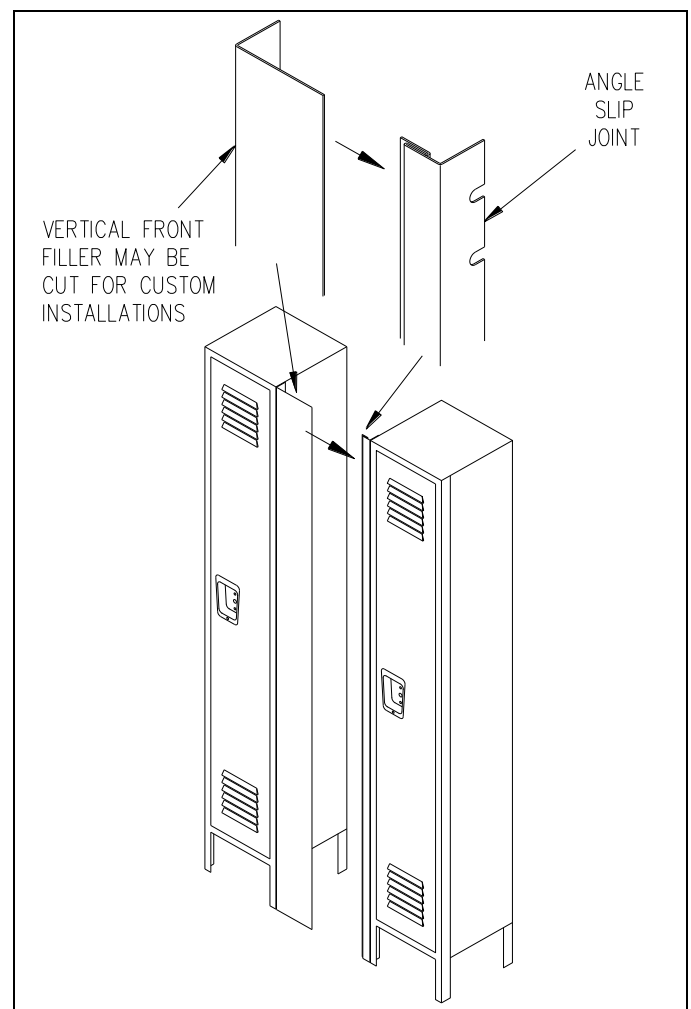

### SALSBURY INDUSTRIES

18300 Central Avenue, Carson, CA 90746-4008  
Phone: 1-800-562-5377 Int'l Phone: 323-846-6700  
Fax: 1-800-562-5399 Int'l Fax: 323-846-6800  
www.lockers.com engineering@lockers.com

# Locker Options – 77000 Series

## Installation Instructions

### Top Fillers – In-Line

In-line top fillers are used to close the tops of gaps between in-line lockers after vertical front fillers have been installed. The in-line flat top filler and the in-line sloping hood filler attach in the same manner. After installing the vertical front filler pieces, place the in-line top fillers on top of the locker gap as shown in the illustration below. Attach the fillers with six (6) #8 TEK self-drilling screws through the holes provided in the in-line top filler.

The in-line top fillers may be cut to special widths for custom installations. The self-drilling screws will make new holes where the original holes were cut away.

As an alternate method, the 15" wide top filler may be used to cover any gap or front filler width smaller than 15" without trimming the top filler width as shown in the illustration below. Simply use the full width top filler as is and place it into a position straddling the smaller opening between locker tops.

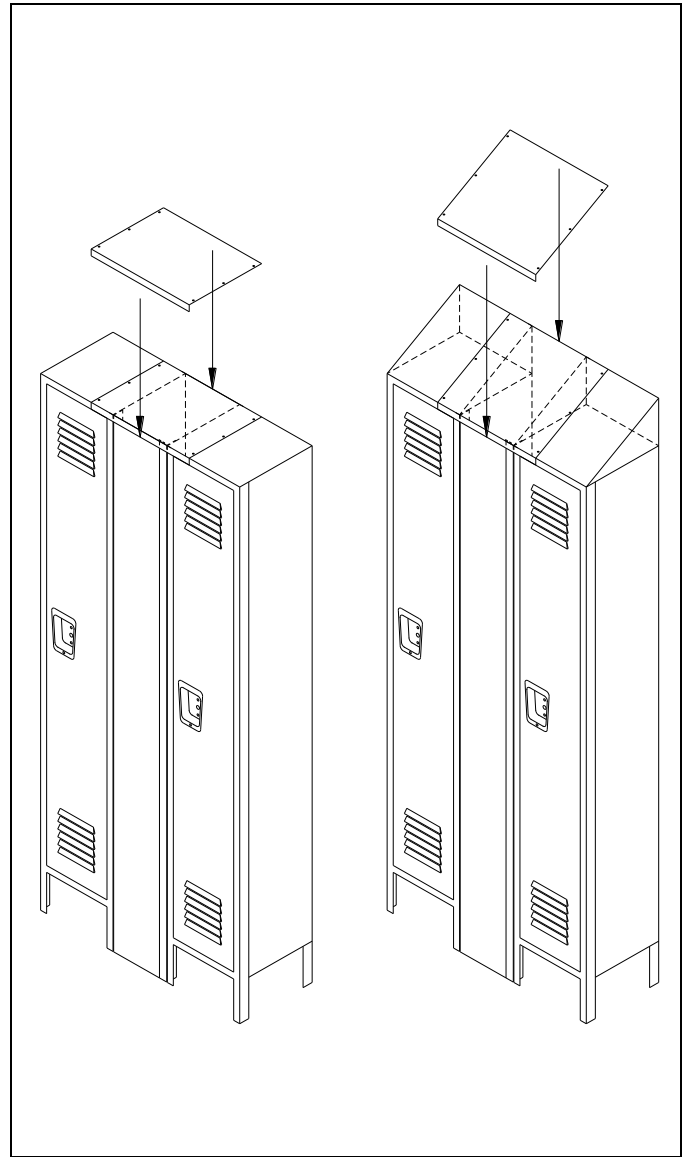
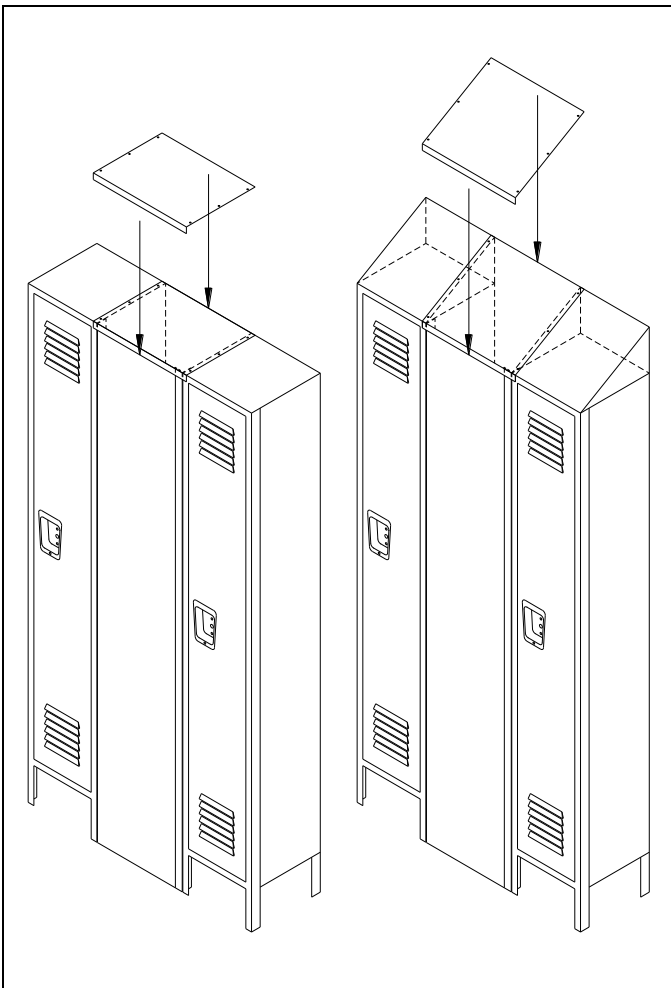

### SALSBURY INDUSTRIES

18300 Central Avenue, Carson, CA 90746-4008  
Phone: 1-800-562-5377 Int'l Phone: 323-846-6700  
Fax: 1-800-562-5399 Int'l Fax: 323-846-6800  
www.lockers.com engineering@lockers.com

# Locker Options – 77000 Series

## Installation Instructions

### Finished End Panel – Single Locker Depth

Installation of the single locker depth end panels requires drilling holes into the side wall of a locker. Start by placing the finished end panel against the side of the locker aligning its top edge with the top of the locker and with the two end flanges facing the locker. Position the notched corners at the front of the locker. Drill 1/4" diameter holes through each hole in the finished end panel through the side wall of the locker. Insert then tighten slotless screws and nuts provided into each drilled hole. Installation is complete.

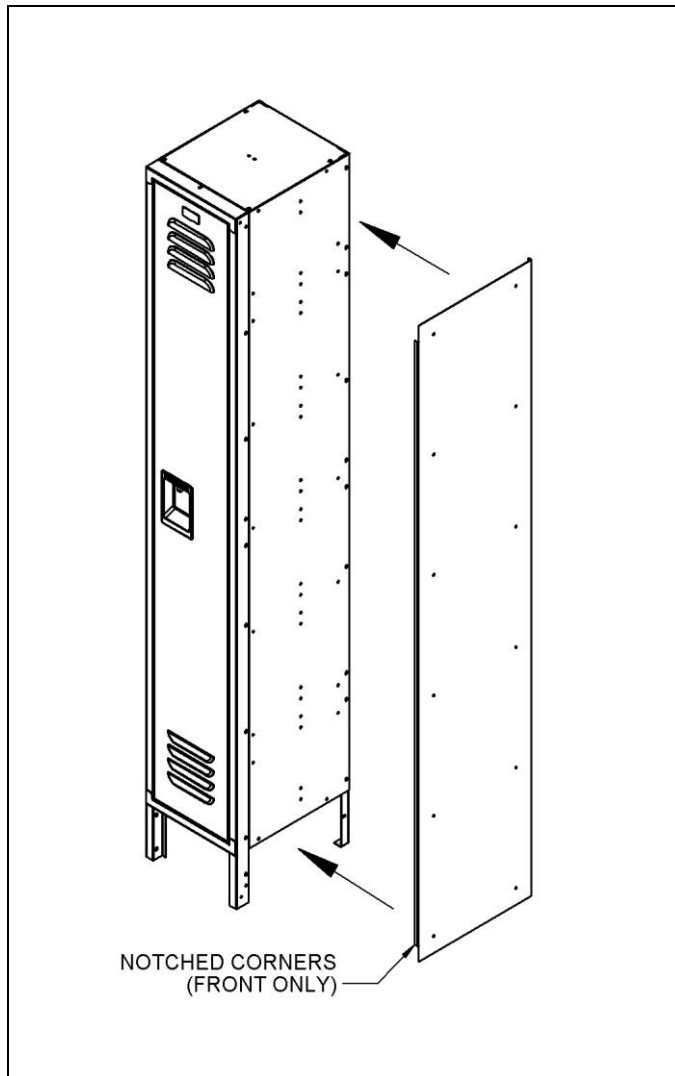

### Finished End Panel – Double Locker Depth

Installation of the double locker depth end panels requires drilling holes into the side wall of each locker. Start by placing the finished end panel against the side of the lockers aligning its top edge with the top of the lockers and with the two end flanges facing the locker. Drill 1/4" diameter holes through each hole in the finished end panel through the side wall of the lockers. Insert then tighten slotless screws and nuts provided into each drilled hole. Installation is complete.

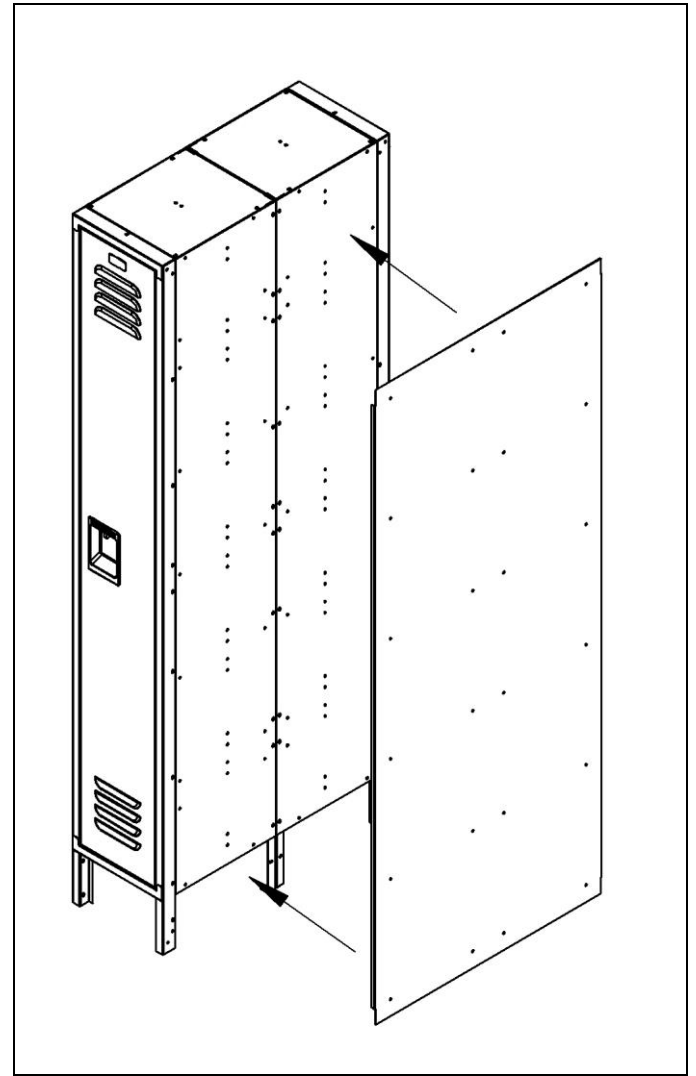

### SALSBURY INDUSTRIES

18300 Central Avenue, Carson, CA 90746-4008  
Phone: 1-800-562-5377 Int'l Phone: 323-846-6700  
Fax: 1-800-562-5399 Int'l Fax: 323-846-6800  
www.lockers.com engineering@lockers.com

# Locker Options – 77000 Series

## Installation Instructions

### Additional Shelves

Additional shelves are installed by turning the shelf sideways to insert through the opening in the locker then turning sideways in the opposite direction to align the two holes in each side flange with existing holes on the side walls of the locker. Attach to the locker with hardware provided. Note, the rear and sides of the additional shelf will fit flush against the rear and side walls of the locker.

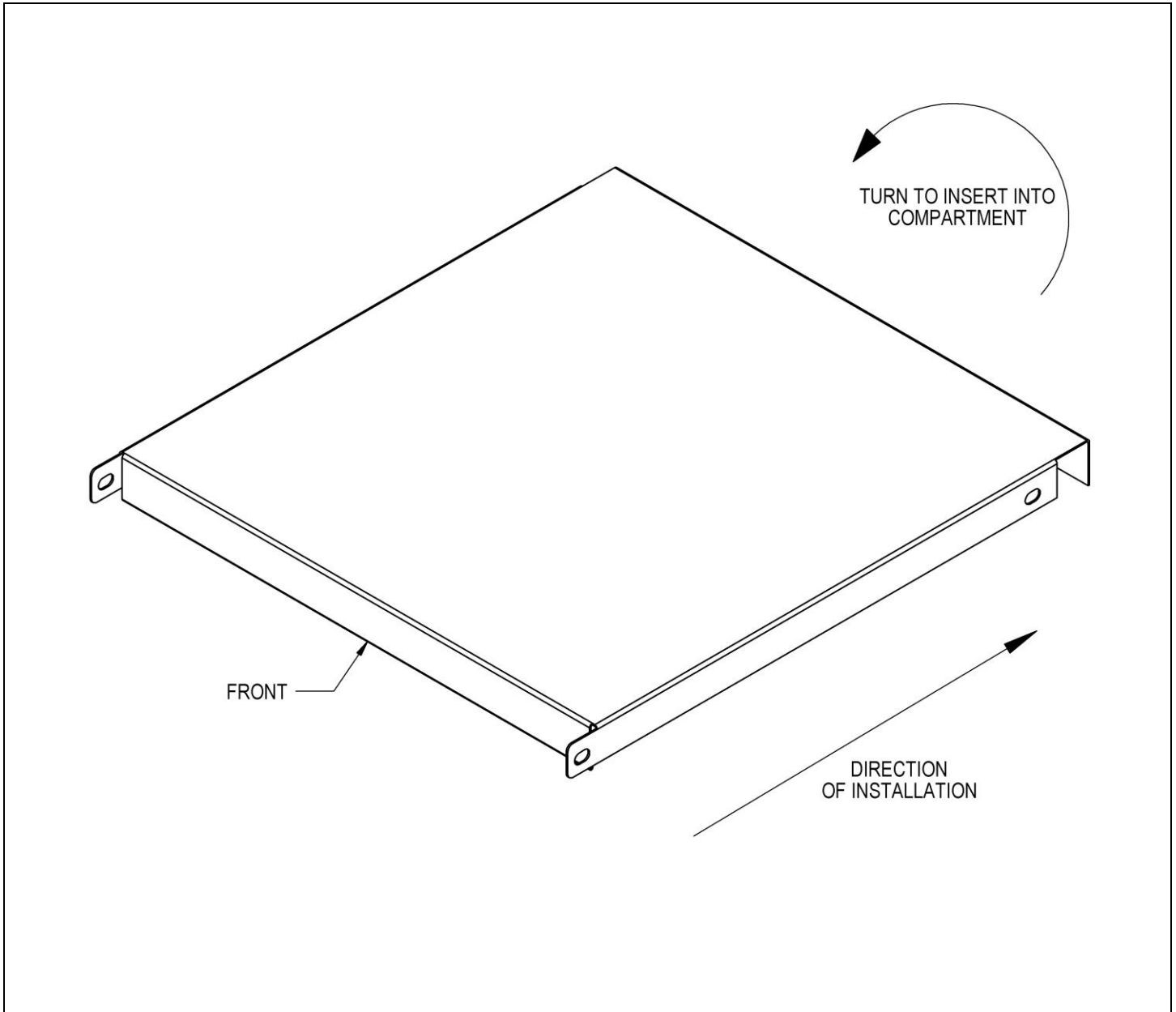

### SALSBURY INDUSTRIES

18300 Central Avenue, Carson, CA 90746-4008  
Phone: 1-800-562-5377 Int'l Phone: 323-846-6700  
Fax: 1-800-562-5399 Int'l Fax: 323-846-6800  
www.lockers.com engineering@lockers.com

# Locker Options – 77000 Series

## Installation Instructions

### Anchoring Brackets - One Wide Locker Without Legs

#### Step 1 – Drill Anchor Hole Locations

Begin the locker installation by placing the locker on its back. Clamp the appropriate drill template (provided) onto the bottom shelf against each side wall of the locker. The appropriate drill template is the one that measures 4" shorter than the locker depth. Drill four (4) 3/16" diameter holes and four (4) 3/8" diameter holes through the bottom shelf of the locker in the locations depicted on the templates.

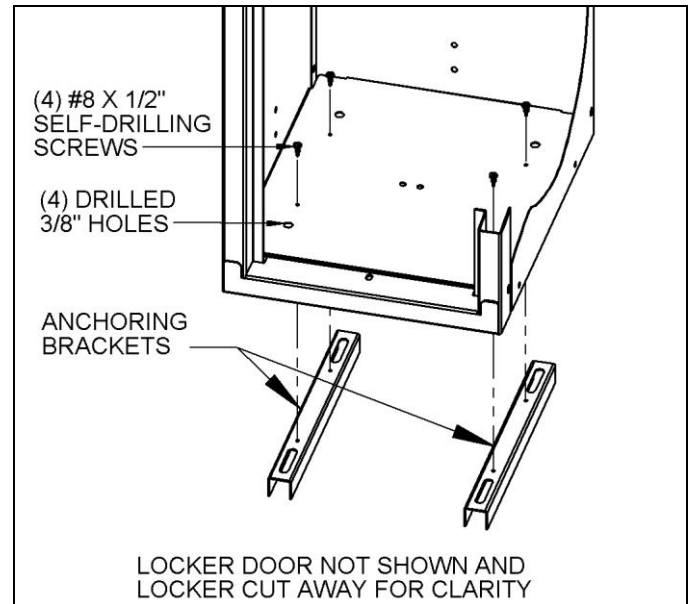
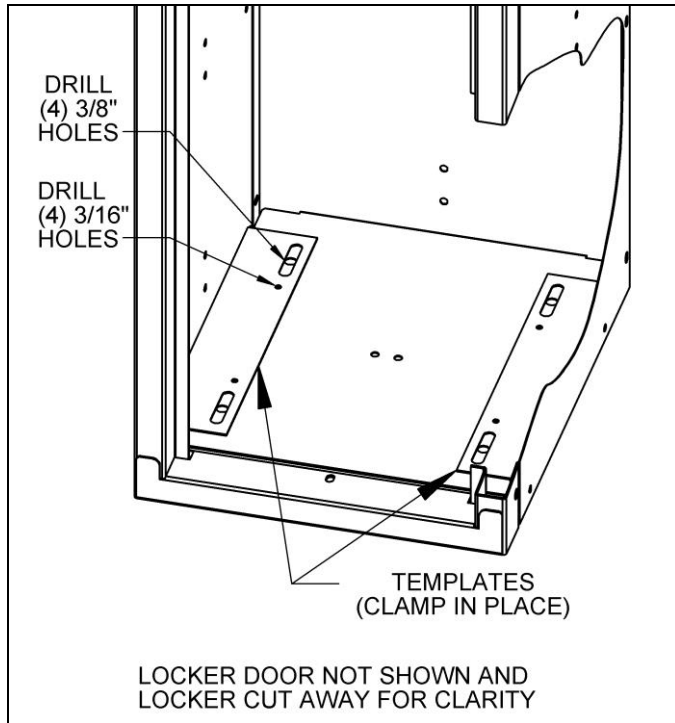

#### Step 3 – Fasten Locker to Concrete

Attach the locker to the concrete base or floor by installing four (4) 1/4" concrete screws of appropriate length (not included) and four (4) 1/4" flat washers (not included) through the four (4) drilled 3/8" diameter holes in the bottom shelf, through the slots in the anchoring brackets, and through the holes drilled into the concrete. The four (4) #8 x 1/2" long self-drilling screws (provided) may be removed after installing the concrete screws. Installation is now complete.

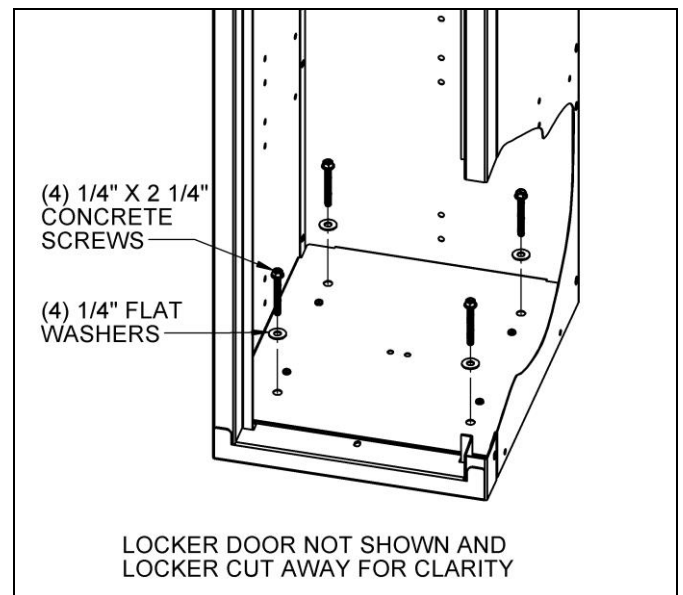

### SALSBURY INDUSTRIES

18300 Central Avenue, Carson, CA 90746-4008  
Phone: 1-800-562-5377 Int'l Phone: 323-846-6700  
Fax: 1-800-562-5399 Int'l Fax: 323-846-6800  
www.lockers.com engineering@lockers.com

# Locker Options – 77000 Series

## Installation Instructions

### Anchoring Brackets - Three Wide Locker Without Legs

#### Step 1 – Drill Anchor Hole Locations

Begin the locker installation by placing the locker on its back. Clamp the appropriate drill template (provided) onto the bottom shelf of the left locker against the side wall of the locker. The appropriate drill template is the one that measures 4" shorter than the locker depth. Drill two (2) 3/16" diameter holes and two (2) 3/8" diameter holes through the bottom shelf of the locker in the locations depicted on the template. Repeat these steps against the right wall of the right locker if no additional lockers are installed next to it.

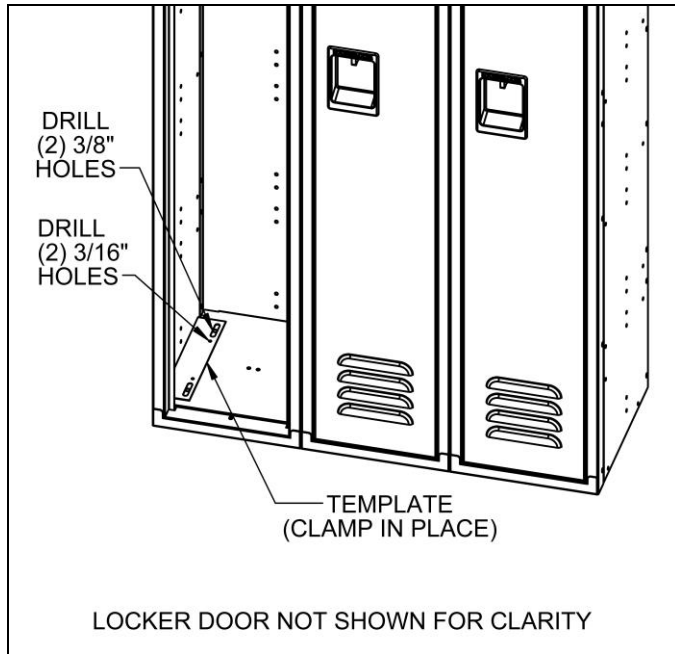

#### Step 2 – Attach Anchor and Drill Concrete Screw Holes

Remove the template. Attach an anchoring bracket that is 4" shorter than depth of locker underneath the bottom shelf of the left locker by placing two (2) #8 x 1/2" long self-drilling screws (provided) through the two (2) drilled 3/16" diameter holes in the bottom shelf and through the pre-drilled holes in the anchoring bracket. Set the locker in place on the concrete base or floor. Drill two (2) 3/16" diameter holes into the concrete base or floor through the two (2) drilled 3/8" diameter holes in the bottom shelf and through the slots in the anchoring brackets. Drill holes at least 2-3/8" deep from the top surface of the bottom shelf. Repeat these steps to the right locker if installing an additional anchor.

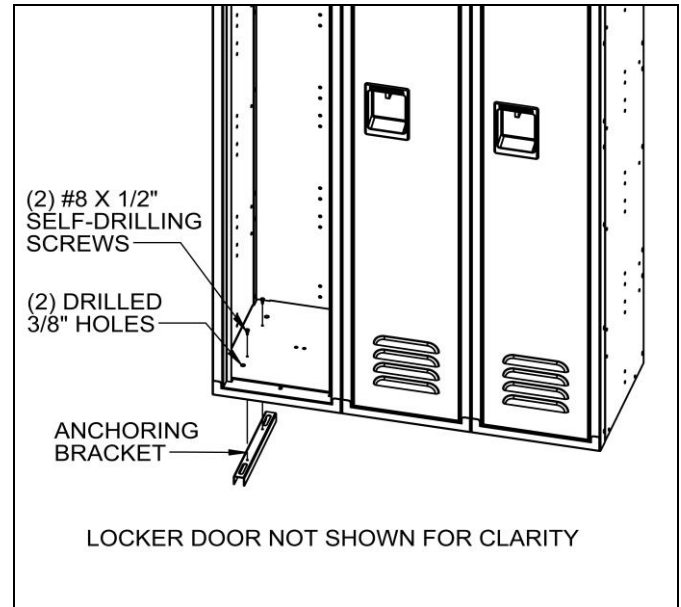

#### Step 3 – Fasten Locker to Concrete

Attach the locker to the concrete base or floor by installing two (2) 1/4" concrete screws of appropriate length (not included) and two (2) 1/4" flat washers (not included) through the two (2) drilled 3/8" diameter holes in the bottom shelf, through the slots in the anchoring bracket, and through the holes drilled into the concrete. The two (2) #8 x 1/2" long self-drilling screws (provided) may be removed after installing the concrete screws. Repeat these steps on the far right locker. To complete the installation, bolt all lockers in a row together through their side walls with fasteners provided. Installation is now complete.

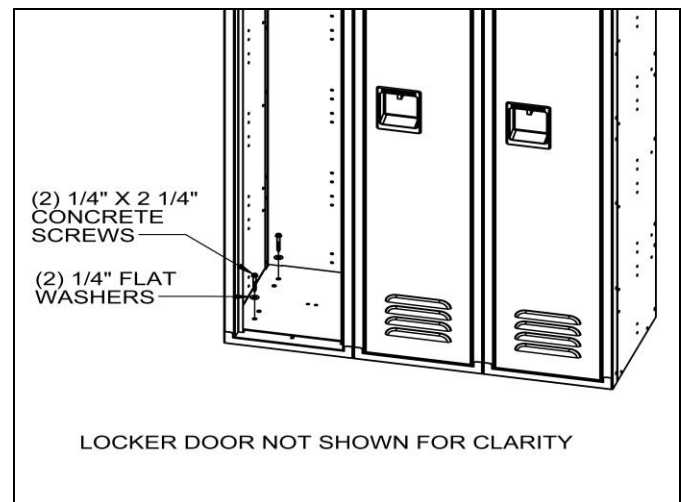

### SALSBURY INDUSTRIES

18300 Central Avenue, Carson, CA 90746-4008  
Phone: 1-800-562-5377 Int'l Phone: 323-846-6700  
Fax: 1-800-562-5399 Int'l Fax: 323-846-6800  
www.lockers.com engineering@lockers.com

# Locker Options – 77000 Series

## Installation Instructions

### Zee Base Installation

#### Step 1 – Install the Zee Base

Each zee base kit contains one (1) zee base channel, two (2) end/splice pieces, one (1) corner angle and four (4) rear legs (not shown). Begin the zee base installation by determining the placement of the necessary zee base components. The illustration below demonstrates how the various components contained in the zee base kit can be used. Position the predrilled holes on the zee base channel against the floor. Connect the end/splice pieces using #10 - 24 x 3/8" long slotless screws and #10 nuts (provided). Complete the installation by attaching the channels to the floor and the end/splice pieces to the wall with appropriate anchoring hardware (not included). Discard any unused pieces.

#### Step 2 – Install the Rear Legs

Before positioning the lockers (not shown) onto the zee-base, install the rear legs included in the zee base kit to the lockers. The #10 - 24 x 1/2" long screws and #10 nuts with a serrated washer included in the kit are to be used. If lockers are shipped with legs, remove all legs from the lockers and replace the rear legs with those included in the zee base kit. The rear legs included with the lockers may be discarded.

#### Step 3 – Install the Lockers

Position the lockers onto the zee base in the desired location and attach them to the zee base using self-drilling sheet metal screws (not included). These are to be installed from the underside of the zee base. Anchor lockers to the wall if applicable. Next fasten all lockers in a row together by installing the fasteners provided with the lockers through the side panels and rear panels. Installation is now complete.

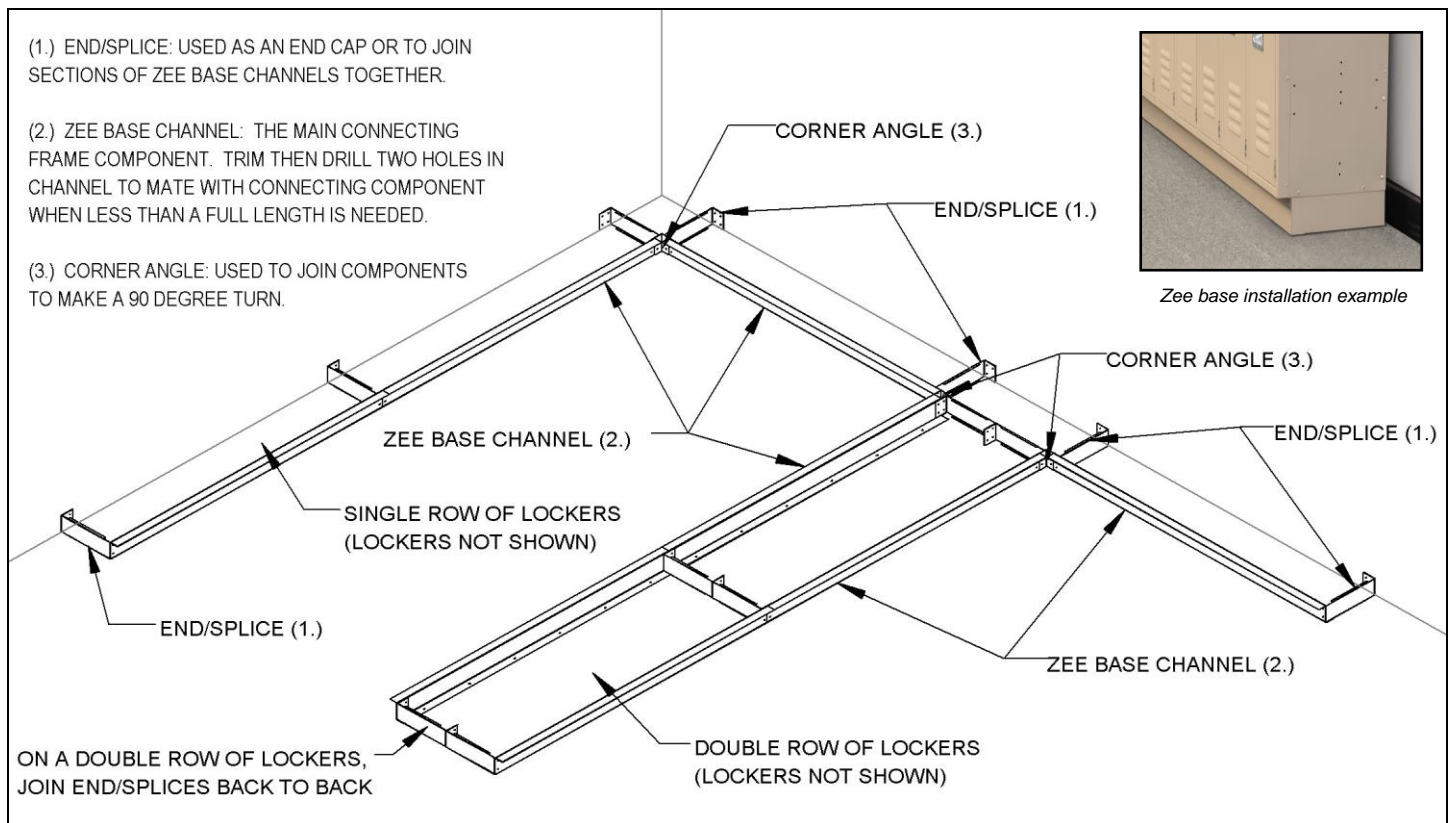

### SALSBURY INDUSTRIES

18300 Central Avenue, Carson, CA 90746-4008  
Phone: 1-800-562-5377 Int'l Phone: 323-846-6700  
Fax: 1-800-562-5399 Int'l Fax: 323-846-6800  
www.lockers.com engineering@lockers.com