

# IMPACT WRENCHES

## MORE POWER - LESS NOISE



AIRCAT® offers the most loosening torque in our impact wrench, while only creating 86 dBA of sound, compared to the industry average of 112 dBA. Most

of the Pneumatic Tool industry measures tool performance on power and durability, which AIRCAT® ranks in the top 2 in both categories amongst users.

AIRCAT® offers a large selection of impact wrenches from 3/8" to 1" drive ranging from 80 ft-lb. to 2300 ft-lb. of torque.



# AIRCAT IMPACT WRENCH MECHANISMS AND PERFORMANCE CHARACTERISTICS

**VIBROTHERM DRIVE®** is a new AIRCAT patented mechanism that provides faster blow frequency, high torque, low vibration and a longer working life than other conventional impact wrench mechanisms. In addition, it reduces overall tool length. The cage is driven by the motor that drives the two hammers to generate two blows for each revolution. The elimination of hammer pins and the addition of the front hammer cage plate, that retains the grease within the mechanism, reduces wear within the mechanism increasing working life.

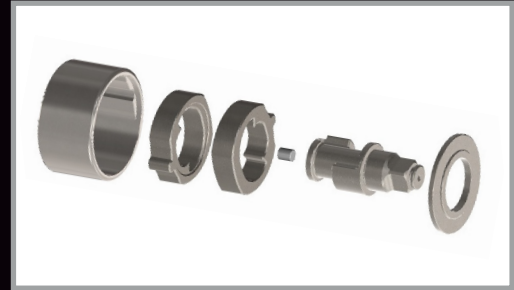

The **TWIN HAMMER** is the most widely used impact wrench mechanism that provides fast blow frequency and high torque. The mechanism is most found in the AIRCAT 3/8", 1/2" and 3/4" impact wrenches. The cage is driven by the motor that drives the twin hammers that rock on hammer pins that pass through the hammer cage to generate two blows for each revolution.

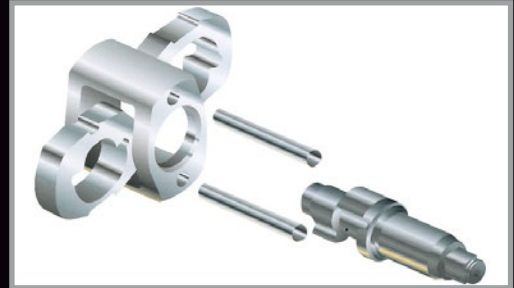

The **PIN-LESS HAMMER** is used in AIRCAT 1" impact wrenches. The PIN-LESS mechanism has a more positive drive and uses fewer moving parts – this design increases reliability for heavy duty applications. The large single hammer provides hard hitting power to achieve rapid high torque. The cage is driven by the motor that drives the large single hammer to generate one hard hitting blow for each revolution.

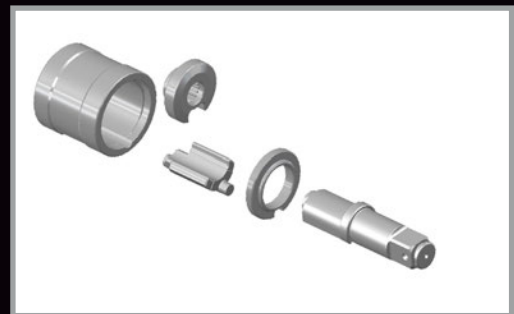

The **TWIN CLUTCH** is featured in NITROCAT 1/2" impact wrenches and 1750-K 3/4" impact wrenches. The twin clutch is specifically designed to provide smooth and powerful operation and to create high initial torque. This mechanism outperforms other mechanism in high torque engine service and repair work, and particularly for removal of stubborn crank shaft bolts. When the hammer rotates past the anvil, a ball pushes the pins forward engaging them with the anvil, the pins are then pushed backwards by the spring. This mechanism has very fast acceleration that creates the high initial torque.

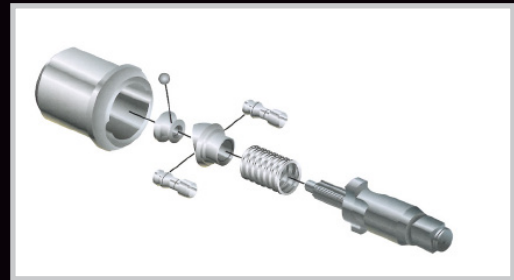

The **JUMBO HAMMER** is used in AIRCAT and NITROCAT compact impact wrenches. The JUMBO hammer enables AIRCAT to provide high torque and high reliability in its smallest impact wrenches. The cage is driven by the motor that drives the single JUMBO hammer that rocks on hammer pins that pass through the hammer cage to generate one hard hitting blow for each revolution.



The **TWO JAW CLUTCH** is featured exclusively in the AIRCAT 1890-P 1" Pistol Grip Impact Wrench. The TWO JAW clutch provides unparalleled torque output and longer life than any other mechanism. The cage is driven by the motor and the jaws on the cage directly drive the anvil. This action eliminates the customary hammering, increasing torque and reducing wear. The internal spring then disengages the jaws to turn to the next drive cycle. The mechanism is ideal for heavy duty off road vehicle work and steel erection.



# IMPACT WRENCHES

## 1991

### 1" STRAIGHT IMPACT WRENCH WITH 6" EXTENDED ANVIL

- Provides 2,100 ft-lb maximum torque and 2,300 ft-lb of loosening torque
- Unmatched power to weight ratio
- Exhaust can be located at either the top or bottom of tool
- Rubber handle grips and rubberized trigger inserts for ultimate comfort
- Combined friction-ring and through-hole socket retainers



1991 Includes Grey Pneumatic® Sockets (33mm \ 1-1/2-in)

## 1991-1

### 1" STRAIGHT IMPACT WRENCH



## 1993-VXL

### 1" VIBROTHERM DRIVE® COMPOSITE STRAIGHT IMPACT WRENCH WITH 7" ANVIL

- Provides 2,100 ft-lb maximum torque and 2,300 ft-lb of loosening torque
- VIBROTHERM DRIVE® impact wrenches incorporates the new patented AIRCAT® design impact wrench mechanism
- The new mechanism reduces vibration levels by 30%-40% and increases the life of the mechanism by 50%
- 6,000 RPM Free Speed
- Unmatched power-to-weight ratio
- Rubber handle grip and rubberized trigger inserts for ultimate comfort
- Combined friction-ring and through-hole socket retainer
- Investment in tooling, materials, and the triple injection molding processes enables AIRCAT® to produce cosmetic designs that are unmatched in the industry



## 1993-1-VXL

### 1" VIBROTHERM DRIVE® COMPOSITE STRAIGHT IMPACT WRENCH



## SPECIFICATIONS

Model No.	Free Speed (RPM)	Bolt Capacity (in.)	Square Drive (in.)	Impacts Per Minute	Max. Torque (ft-lb) @90 psi	Weight (lbs.)	Length (in)	Air Cons. (CFM)	Rec. Hose Size (in.)	Air Inlet NPT (in.)
1991	6,000	1-1/4	1 x 6	1600	2100	20.7	19.0	8	1/2	1/2
1991-1	6,000	1-1/4	1	1600	2100	16.7	12.9	8	1/2	1/2
1993-VXL	6,000	1-1/4	1 x 7	950	2100	20.2	18.7	10	1/2	1/2
1993-1-VXL	6,000	1-1/4	1	950	2100	18.5	13.4	10	1/2	1/2

# TECHNICAL INFORMATION

## Air Supply

Tools of this class operate on a wide range of air pressure. It is recommended that air pressure of these tools measures 90 PSI at the tool while running free. Higher pressure and unclean air will shorten the tool's life because of faster wear and may create a hazardous condition and void the warranty. Water in the air line will cause damage to the tool. Drain the air tank daily. Clean the air inlet filter screen on at least a weekly schedule.

The recommended hookup procedure can be viewed in the illustration below. The air inlet used for connecting air supply has standard 1/4" NPT for smaller tools and 3/8" NPT for larger tools as specified in the tool manual. Line pressure should be increased to compensate for unusually long air hoses (over 25 feet). Minimum hose diameter should be 3/8" I.D. for smaller tools and 1/2" for larger tools as specified in the tool manual.

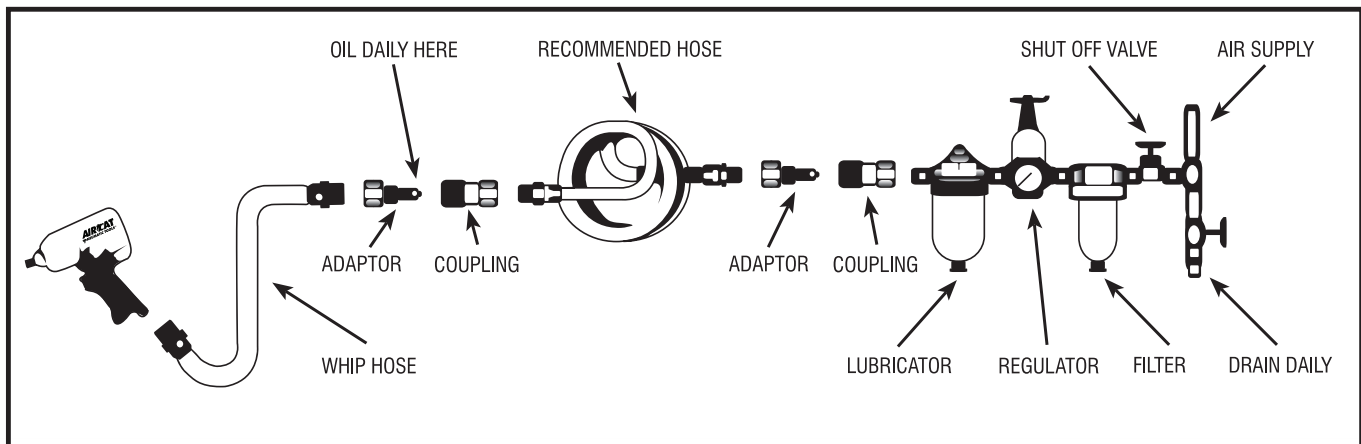

### Use of Accessories with Air Tools

When selecting the correct accessory to use with your air tool(s) the following points must be carefully checked:

- The accessory is rated to run at or above the maximum rated speed of the air tool that you plan to use it on.
- Air tool Manufacturers specify these speeds in their catalogs and operator instructions.
- Accessories used on abrasive tools, impact wrenches, nut runners, ratchets, air hammers and scaling hammers must be rated for use with the relevant air tool.
- Any accessory used should be of the correct size and design for the air tool(s) that you plan to use it with.
- Worn accessories should not be used and accessories should not be modified in any way.
- Mounting and fitting instruction for any accessory to be used on an air tool must be carefully followed at all times.
- Use of worn or incorrect accessories may reduce tool performance, create excessive tool wear and can be hazardous
- Always disconnect the tool from the air supply when changing of fitting accessories, guards or other fittings.

### Operator Training for Air Tool; Air Tool Accessory and Compressed Air Use

- All operators should be trained in the correct installation and use of the air tool/s that they are required to operate.
- All operators should be trained to understand the safety instructions provided by the air tool manufacturer, for each
- Air tool that they are required to operate.
- All operators should be trained in the safe use of compressed air and the use of associated air hoses, connectors and air tool accessories.
- All operators should be trained to operate an air tool and accessories safely and correctly on the application that you plan to use them for.
- Operators or service personnel should be trained to ensure that the air installation, lubricators, filters, regulators, hoses and air nipples and connectors are checked regularly to ensure that they meet the requirements set on a continuous basis.

## ***How To Maximize Your Tools Performance And Working Life.***

Compressed air is a misunderstood power source as unlike electricity that is constant and maintains constant horsepower, as compressed air drives a motor horsepower can vary dependent on how the tool is set up. The tips below will ensure that you maximize the horse power of the air motor and torque level of your impact wrench:

Air tool manufactures measure the impact wrench rated torque levels stated in there catalogs and rated horse power and RPM of the air tools stated in their catalogs based on 90 PSI are pressure entering the tool at the tool air inlet.

If the air pressure is set at the compressor or at an in-line pressure regulator at 90 PSI by the time that the air reaches the tools air inlet; the pressure will have dropped. Typically each 25' between the air pressure gauge and the tool with cause a 15% air pressure drop at the tool. In addition any restriction added to a hose hook-up, like a connector that reduces the inside diameter of the air connection will cause a severe pressure drop at the tool. Then any air leak at a connection point between the compressor and the tool will reduce air pressure. Use of the wrong air hose ID size will typically reduce tool performance by 40%-50%. Use of very small compressors to run air tools will dramatically reduce performance.

### ***Tips To Maximize Tool Performance:***

- Always use the air hose ID size recommended by the tool manufacturer.
- For any impact wrench up to 1/2" drive and other air tools always use a 3/8" ID air hose.
- For any impact wrench 3/4" and 1" drive always use a 1/2" ID air hose.
- Reduce the hose length to the shortest length practical for use, as a guide if a 25" air hose is used the pressure at the in-line regulator should be set at 105-110 PSI this will deliver 90 PSI to the tool
- Ensure that thread tape is used on all connections from the compressor to the tool
- Do not use connectors or reducers in the air hose hook-up.
- For impact wrenches up to 1/2" drive and most other air tools a compressor with a minimum 20 gallon tank and 5 HP motor should be used. For 3/4" & 1" impact wrenches, sanders and heavy grinders a compressor with a minimum 40 gallon tank and 8 HP motor should be used. Note that all pro auto service shops have installed compressors that well exceed the above minimums.

### ***Tips To Maximize Tool Life:***

An air motor is no different than the internal combustion engine in your car, they need oil. Inline lubricators are best. If not installed always add a few drops of air tool oil into the tools air inlet each day before use, and most importantly at the end of the day add a few drops of air tool oil, run the tool for a few seconds before storing overnight.

In certain conditions compressed air generates water vapor that if entering the tool will corrode the internal motor parts, moisture traps should be fitted in to your air supply system.

Impact wrench hammer mechanisms require grease, normally it is adequate to replace the grease at the tools service interval or after six months use.

# AIRCAT WARRANTY



AIRCAT and NITROCAT® air tools are warranted to be free from defects in material and workmanship for 2 years from date of purchase. We will repair or replace; at our option any defective part or unit which proves to be defective in material or workmanship during this 2 year period.



VIBROTHERM DRIVE® air tools and our low weight 1" impact series models (1991, 1991-1 and 1870-P) are warranted to be free from defects in material and workmanship for 3 years from date of purchase. We will repair or replace; at our option any defective part or unit which proves to be defective in material or workmanship during this 3 year period.

The foregoing obligation is AIRCAT and Florida Pneumatic's sole liability under this or any implied warranty, under no circumstances shall it be liable for any incidental or consequential damages.

This warranty applies to the tool only. This warranty does not apply to any attached accessories/ consumable products; such as drill chucks, sander backing pads, air hammer retainers and chisels or "kit" accessories or any other accessory included with the tool.

Any repair required due to normal wear and tear, abuse, misuse, modification of the tool or repair attempts (by other than an AIRCAT® or Florida Pneumatic Authorized Service Center) are not covered by this warranty.

Return your tool to an AIRCAT® or Florida Pneumatic Authorized Service Center freight prepaid. Be sure to include your name, address, copy of purchase with date and description of the suspected defect.

AIRCAT® whose policy is continued product improvement reserves the right to make changes in design or construction at any time without incurring any obligation on tools previously sold.

## INDUSTRY ASSOCIATIONS

