

12 Point Combination Ratcheting Wrenches

- 72 tooth ratcheting box end needs a minimal 5° to move fasteners vs. 30° for standard wrenches
- Off-corner loading design on box end provides better grip and reduces fastener rounding
- Thin head and beam provide greater access in confined work areas
- Size conveniently stamped on both ends of the beam for quick identification
- Manufactured from alloy steel for better strength and longer tool life
- Bright, full polish chrome finish easily wipes clean and resists corrosion
- Meets or exceeds ASME and ANSI specifications

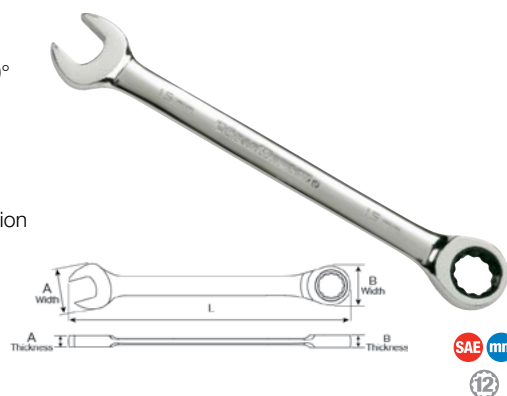

Cat. No.	SAE/Metric	Fastener Size	End A Width	End A Thickness	End B Width	End B Thickness	Overall Length	Product Weight
9008	SAE	1/4 in	0.567 in	0.181 in	0.61 in	0.256 in	4.921 in	0.10 lb
9010D	SAE	5/16 in	0.768 in	0.197 in	0.665 in	0.272 in	5.508 in	0.12 lb
9011D	SAE	11/32 in	0.768 in	0.213 in	0.701 in	0.272 in	5.882 in	0.12 lb
9012D	SAE	3/8 in	0.862 in	0.224 in	0.78 in	0.303 in	6.256 in	0.14 lb
9014	SAE	7/16 in	0.953 in	0.252 in	0.854 in	0.323 in	6.508 in	0.17 lb
9016D	SAE	1/2 in	1.146 in	0.319 in	0.984 in	0.339 in	7.008 in	0.22 lb
9018D	SAE	9/16 in	1.228 in	0.327 in	1.035 in	0.37 in	7.504 in	0.23 lb
9020	SAE	5/8 in	1.358 in	0.346 in	1.201 in	0.406 in	8.201 in	0.33 lb
9022	SAE	11/16 in	1.492 in	0.362 in	1.272 in	0.421 in	8.878 in	0.38 lb
9024	SAE	3/4 in	1.626 in	0.374 in	1.339 in	0.441 in	9.764 in	0.47 lb
9026D	SAE	13/16 in	1.811 in	0.39 in	1.535 in	0.512 in	11.476 in	0.86 lb
9028D	SAE	7/8 in	1.811 in	0.39 in	1.535 in	0.512 in	11.476 in	0.80 lb
9030	SAE	15/16 in	2.055 in	0.429 in	1.791 in	0.571 in	13.114 in	1.17 lb
9032	SAE	1 in	2.055 in	0.429 in	1.791 in	0.571 in	13.114 in	1.15 lb
9034	SAE	1-1/16 in	2.22 in	0.571 in	1.929 in	0.61 in	14.142 in	1.32 lb
9036	SAE	1-1/8 in	2.469 in	0.492 in	2.154 in	0.669 in	15.846 in	1.97 lb
9038D	SAE	1-1/4 in	2.634 in	0.508 in	2.283 in	0.689 in	16.764 in	2.18 lb
9060D	SAE	1-5/16 in	2.744 in	0.539 in	2.362 in	0.689 in	18.11 in	2.64 lb
9062D	SAE	1-3/8 in	2.744 in	0.539 in	2.362 in	0.689 in	18.11 in	2.64 lb
9040	SAE	1-7/16 in	3.114 in	0.646 in	2.52 in	0.807 in	19.685 in	3.86 lb
9042	SAE	1-1/2 in	3.114 in	0.646 in	2.52 in	0.807 in	19.685 in	3.82 lb
9044	SAE	1-9/16 in	3.409 in	0.709 in	2.677 in	0.866 in	22.638 in	5.18 lb
9046D	SAE	1-5/8 in	3.409 in	0.709 in	2.677 in	0.866 in	22.638 in	5.14 lb
9048	SAE	1-11/16 in	3.626 in	0.791 in	2.835 in	0.925 in	24.213 in	5.69 lb
9050D	SAE	1-3/4 in	3.626 in	0.791 in	2.835 in	0.925 in	24.213 in	5.64 lb
9052D	SAE	1-13/16 in	3.85 in	0.835 in	2.992 in	0.984 in	25.394 in	7.65 lb
9054D	SAE	1-7/8 in	3.85 in	0.835 in	2.992 in	0.984 in	25.394 in	7.59 lb
9056D	SAE	2 in	4.134 in	0.835 in	3.15 in	1.043 in	25.787 in	8.34 lb
9106	Metric	6 mm	0.567 in	0.181 in	0.61 in	0.256 in	4.921 in	0.09 lb
9107	Metric	7 mm	0.642 in	0.189 in	0.622 in	0.256 in	5.236 in	0.07 lb
9108D	Metric	8 mm	0.768 in	0.197 in	0.665 in	0.272 in	5.508 in	0.10 lb
9109	Metric	9 mm	0.768 in	0.213 in	0.701 in	0.272 in	5.882 in	0.11 lb
9110D	Metric	10 mm	0.862 in	0.224 in	0.78 in	0.303 in	6.256 in	0.15 lb
9111	Metric	11 mm	0.953 in	0.252 in	0.854 in	0.323 in	6.508 in	0.15 lb
9112	Metric	12 mm	1.047 in	0.291 in	0.906 in	0.339 in	6.756 in	0.20 lb
9113D	Metric	13 mm	1.146 in	0.319 in	0.984 in	0.339 in	7.008 in	0.23 lb

Cat. No.	SAE/Metric	Fastener Size	End A Width	End A Thickness	End B Width	End B Thickness	Overall Length	Product Weight
9114D	Metric	14 mm	1.228 in	0.327 in	1.035 in	0.37 in	7.504 in	0.27 lb
9115D	Metric	15 mm	1.327 in	0.327 in	1.13 in	0.39 in	7.854 in	0.25 lb
9116D	Metric	16 mm	1.358 in	0.346 in	1.201 in	0.406 in	8.201 in	0.33 lb
9117D	Metric	17 mm	1.492 in	0.362 in	1.272 in	0.421 in	8.878 in	0.38 lb
9118D	Metric	18 mm	1.583 in	0.37 in	1.307 in	0.441 in	9.311 in	0.46 lb
9119	Metric	19 mm	1.626 in	0.374 in	1.339 in	0.441 in	9.764 in	0.47 lb
9120	Metric	20 mm	1.811 in	0.39 in	1.535 in	0.512 in	11.476 in	0.78 lb
9121	Metric	21 mm	1.811 in	0.39 in	1.535 in	0.512 in	11.476 in	0.81 lb
9122	Metric	22 mm	1.811 in	0.39 in	1.535 in	0.512 in	11.476 in	0.80 lb
9124	Metric	24 mm	2.055 in	0.429 in	1.791 in	0.571 in	13.114 in	1.15 lb
9125D	Metric	25 mm	2.055 in	0.429 in	1.791 in	0.571 in	13.114 in	1.16 lb
9127D	Metric	27 mm	2.22 in	0.571 in	1.929 in	0.61 in	14.142 in	1.32 lb
9130D	Metric	30 mm	2.469 in	0.492 in	2.154 in	0.669 in	15.846 in	1.75 lb
9132	Metric	32 mm	2.634 in	0.508 in	2.283 in	0.689 in	16.764 in	2.21 lb
9134D	Metric	34 mm	2.744 in	0.539 in	2.362 in	0.689 in	18.11 in	2.61 lb
9136	Metric	36 mm	3.114 in	0.646 in	2.52 in	0.807 in	19.685 in	4.45 lb
9141D	Metric	41 mm	3.409 in	0.709 in	2.677 in	0.866 in	22.638 in	5.73 lb
9146D	Metric	46 mm	3.85 in	0.835 in	2.992 in	0.984 in	25.394 in	7.92 lb
9150	Metric	50 mm	4.134 in	0.835 in	3.15 in	1.043 in	25.787 in	8.78 lb

14 Pc. 12 Point SAE/Metric Stubby Combination Ratcheting Wrench Set

- 72 tooth ratcheting box end needs a minimal 5° to move fasteners vs. 30° for standard wrenches
- Off-corner loading design on box end provides better grip and reduces fastener rounding
- Thin head and beam provide greater access in confined work areas
- Manufactured from alloy steel for better strength and longer tool life
- Bright, full polish chrome finish easily wipes clean and resists corrosion
- Stubby beam length for when clearance is limited
- Meets or exceeds ASME and ANSI specifications
- Included tray for storage and organization



Cat. No.	Included Storage	Product Weight
85206	Tray	3.740 lb

Cat. No.	Description	Cat. No.	Description
9500DD	3/8" 12 Point Stubby Ratcheting Combination Wrench	9510DD	10mm 12 Point Stubby Ratcheting Combination Wrench
9501DD	7/16" 12 Point Stubby Ratcheting Combination Wrench	9511D	11mm 12 Point Stubby Ratcheting Combination Wrench
9502D	1/2" 12 Point Stubby Ratcheting Combination Wrench	9512D	12mm 12 Point Stubby Ratcheting Combination Wrench
9503D	9/16" 12 Point Stubby Ratcheting Combination Wrench	9513D	13mm 12 Point Stubby Ratcheting Combination Wrench
9504D	5/8" 12 Point Stubby Ratcheting Combination Wrench	9514D	14mm 12 Point Stubby Ratcheting Combination Wrench
9505D	11/16" 12 Point Stubby Ratcheting Combination Wrench	9515D	15mm 12 Point Stubby Ratcheting Combination Wrench
9506D	3/4" 12 Point Stubby Ratcheting Combination Wrench	9518D	18mm 12 Point Stubby Ratcheting Combination Wrench