



OPERATOR'S MANUAL

IMPORTANT SAFETY INSTRUCTIONS

1. **SAVE THESE INSTRUCTIONS.** This manual contains important safety and operating instructions for the battery charger you have purchased. You may need to refer to these instructions at a later date.
 2. **CAUTION.** To reduce risk of injury, charge only lead-acid rechargeable batteries. Other types of batteries may burst causing personal injury and property damage.
 3. Do not expose the charger to rain or snow if specifically warned on the unit not to do so.
 4. Use of an attachment not recommended or sold by the battery charger manufacturer may result in a risk of fire, electric shock, or injury to persons.
 5. To reduce the risk of damage to the electric plug and cord, pull by the plug rather than the cord when disconnecting the charger.
 6. Make sure the cord is located so that it will not be stepped on, tripped over, or otherwise subjected to damage or stress.
 7. An extension cord should not be used unless absolutely necessary. Use of an improper extension cord could result in a risk of fire and electric shock. If an extension cord must be used, make sure:
 - a. That the pins on the plug of extension cord are the same number, size, and shape as those of the plug on the charger;
 - b. That the extension cord is properly wired and in good condition; and
 - c. If the length of the extension cord is less than 25 feet, use a 16AWG cord, If 50 feet- 12AWG, 100 feet-10AWG, 150 feet-8AWG.
 8. Do not operate the charger with a damaged cord or plug, replace them immediately.
 9. Do not operate the charger if it has received a sharp blow, been dropped, or otherwise damaged in any way; take it to a qualified serviceman.
 10. Do not disassemble the charger; take it to a qualified serviceman when service or repair is required. Incorrect reassembly may result in risk of electric shock or fire.
 11. To reduce the risk of electric shock, unplug the charger from the outlet before attempting any maintenance or cleaning. Turning off the controls will not reduce this risk.
12. **WARNING - RISK OF EXPLOSIVE GASES**
- a. WORKING IN VICINITY OF A LEAD-ACID BATTERY IS DANGEROUS. BATTERIES GENERATE EXPLOSIVE GASES DURING NORMAL BATTERY OPERATION. FOR THIS REASON IT IS OF UTMOST IMPORTANCE THAT EACH TIME BEFORE USING YOUR CHARGER, YOU READ THIS MANUAL AND FOLLOW THE INSTRUCTIONS EXACTLY.
 - b. To reduce the risk of battery explosion, follow these instructions and those published by the battery manufacturer and manufacturer of any equipment you intend to use in vicinity of the battery. Review cautionary markings on these products and on the engine.
13. **PERSONAL PRECAUTIONS**
- a. Someone should be within range of your voice or close enough to come to your aid when you work near a lead-acid battery.
 - b. Have plenty of fresh water and soap nearby in case battery acid contacts skin, clothing, or eyes.
 - c. Wear complete eye protection, and clothing protection. Avoid touching eyes while working near battery.
 - d. If battery acid contacts skin or clothing, wash immediately with soap and water. If acid enter eyes, immediately flood eyes with running cold water for at least 10 minutes and get medical attention immediately.
 - e. NEVER smoke or allow a spark or flame in vicinity of the battery or engine.
 - f. Be extra cautious to reduce risk of dropping a metal tool onto the battery. It might spark or short circuit the battery or other electrical parts that may cause an explosion.
 - g. Remove personal metal items such as rings, bracelets, necklaces, and watches when working with a lead-acid battery. A lead-acid battery can produce a short circuit current high enough to weld a ring or the like to metal, causing a severe burn.
 - h. Use this charger for charging a LEAD-ACID battery only. It is not intended to supply power to a low-voltage electrical system other than in an automotive application. Do not use this battery charger for charging dry-cell batteries that are commonly used with home appliances. These batteries may burst and cause injury to persons and damage to property.
 - i. NEVER charge a frozen battery.
14. **PREPARING TO CHARGE**
- a. If necessary to remove battery from vehicle to charge, always remove the grounded terminal from the battery first. Make sure all accessories in the vehicle are off, so as not to cause an arc.
 - b. Be sure the area around the battery is well ventilated while the battery is being charged. Gas can be forcefully blown away by using a piece of cardboard or other non-metallic material as a fan.
 - c. Clean the battery terminals. Be careful to keep corrosion from coming in contact with eyes.
 - d. Add distilled water in each cell until battery acid reaches level specified by the battery manufacturer. This helps purge excessive gas from cells. Do not overfill. For a battery without cell caps, carefully follow the manufacturer's recharging instructions.
 - e. Study all battery manufacturer's specific precautions such as removing or not removing the cell caps while charging and the recommended rates of charge.
 - f. Determine voltage of the battery by referring to the car owner's manual and make sure that the output voltage selector switch is set at the correct voltage. If the charger has adjustable charge rate, charge the battery initially at the lowest rate.

15. CHARGER LOCATION

- a. Locate the charger as far away from the battery as the DC cables permit.
- b. Never place the charger directly above the battery being charged; gases from the battery will corrode and damage the charger.
- c. Never allow battery acid to drop on the charger when reading the specific gravity or filling battery,
- d. Do not operate the charger in a closed-in area, or restrict ventilation in any way.
- e. Do not set a battery on top of the charger.

16. DC CONNECTION PRECAUTIONS

- a. Connect and disconnect the DC output clamps only after setting the charger switches to the OFF position and removing the AC cord from the electric outlet. Never allow the clamps to touch each other.
- b. Attach the DC clamps to the battery post and twist or rock back and forth several times to make a good connection. This tends to keep the clamps from slipping off the terminals and helps to reduce the risk of sparking.

17. FOLLOW THESE STEPS WHEN THE BATTERY IS INSTALLED IN A VEHICLE. A SPARK NEAR THE BATTERY MAY CAUSE A BATTERY EXPLOSION. TO REDUCE THE RISK OF A SPARK NEAR THE BATTERY:

- a. Position the AC and DC cords to reduce the risk of damage by the hood, door, or moving engine parts.
- b. Stay clear of fan blades, belts, pulleys, and other parts that can cause injury to persons.
- c. Check the polarity of the battery post. The POSITIVE (POS, P, +) battery post usually has a larger diameter than the NEGATIVE (NEG, N, -) post.
- d. Determine which post of the battery is grounded (connected) to the chassis. If the negative post is grounded to the chassis (as in most vehicles), see item "e". If the positive post is grounded to the chassis, see item "f".
- e. For negative-grounded vehicles, connect the POSITIVE (RED) clamp from the battery charger to the POSITIVE (POS, P, +) ungrounded post of the battery. Connect the NEGATIVE (BLACK) clamp to the vehicle chassis, heavy gauge metal part of the frame, or engine block, away from the battery. Do not connect to the carburetor, fuel lines, or sheet metal body parts.
- f. For positive-grounded vehicle, connect NEGATIVE (BLACK) clamp from the battery charger to the NEGATIVE (NEG, N, -) ungrounded post of the battery. Connect POSITIVE (RED) clamp to the vehicle chassis or engine block away from the battery. Do not connect the clamp to the carburetor, fuel lines, or sheet-metal body parts. Connect to a heavy gauge metal part of the frame or engine block.
- g. When disconnecting the charger, turn the switches to OFF, disconnect the AC cord, remove the clamp from the vehicle chassis, and then remove the clamp from the battery terminal.
- h. See the operating instructions for length of charge information.

18. FOLLOW THESE STEPS WHEN THE BATTERY IS OUTSIDE THE VEHICLE. A SPARK NEAR THE BATTERY MAY CAUSE A BATTERY EXPLOSION. TO REDUCE THE RISK OF A SPARK NEAR THE BATTERY:

- a. Check the polarity of the battery post. The POSITIVE (POS, P, +) usually has a larger diameter than the NEGATIVE (NEG, N, -) post.
- b. Attach at least a 24 inch long 6-gauge (AWG) insulated battery cable to the NEGATIVE (NEG, N, -) battery post.
- c. Connect the POSITIVE (RED) charger clamp to the POSITIVE (POS, P, +) post of the battery.
- d. Position yourself and free end of cable as far away from the battery as possible - then connect the NEGATIVE (BLACK) charger clamp to the free end of cable.
- e. Do not face the battery when making the final connection.
- f. When disconnecting the charger, always do so in reverse sequence of connecting procedure, and break the first connection while standing as far away from the battery as practical.
- g. A marine (boat) battery must be removed and charged on shore. To charge it on board requires equipment specially designed for marine use.

19. GROUNDING AND AC POWER CORD CONNECTION INSTRUCTIONS

The charger should be grounded to reduce the risk of electric shock. This charger is equipped with an electric cord having an equipment grounding conductor and a grounding plug. The plug must be plugged into an outlet that is properly installed and grounded in accordance with all local codes and ordinances.

DANGER. Never alter the AC cord or plug provided - if it will not fit the outlet, have a proper outlet installed by a qualified electrician. Improper connection can result in a risk of an electric shock. This battery charger is for use on a nominal 120-volt circuit, and has a grounding plug that looks like the plug illustrated in FIGURE (A). A temporary adapter, which looks like the adapter illustrated in FIGURE (C), may be used to connect this plug to a two-pole receptacle, as shown in FIGURE (B), until a properly grounded outlet can be installed by a qualified electrician.

DANGER. Before using an adapter as illustrated, be certain that the center screw of the outlet plate is grounded. The green-colored rigid ear or lug extending from the adapter must be connected to a properly grounded outlet - make certain it is grounded. If necessary, replace the original outlet cover plate screw with a longer screw that will secure the adapter ear or lug to the outlet cover plate and make ground connection to grounded outlet.

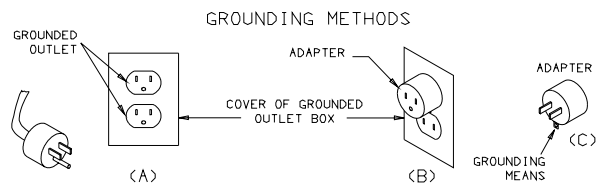

NOTE: USE OF AN ADAPTER IS NOT ALLOWED IN CANADA. IF A GROUNDING TYPE RECEPTACLE IS NOT AVAILABLE, DO NOT USE THIS APPLIANCE UNTIL THE PROPER OUTLET IS INSTALLED BY A QUALIFIED ELECTRICIAN.

ASSEMBLY INSTRUCTIONS

1. Remove the screws from the back of the charger and attach the handle in an upright position with the screws provided.
2. Remove the four screws on the bottom toward the front of the charger and attach the leg with the screws provided.
3. Put one of the axle nuts on one side of the axle by tapping the nut on with a hammer. Then slide the axle through one of the wheels and then through the hole in the charger until it comes out the other end. Put the other wheel and axle on.
4. Attach the clamp bar to the handle with two 10-16x1-1/2 screws included in the hardware bag.

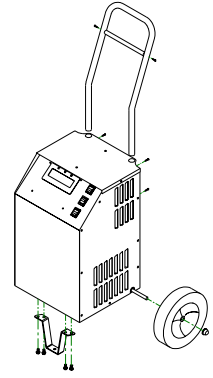

20. CHARGE PERIOD

The approximate required time to bring a battery to full charge state depends upon the number of ampere-hours (AH) depleted from the battery. AHs are determined by multiplying the number of hours times the number of Amps supplied by a battery to a load and normally indicated on the battery. For example - if a load was connected to a battery, which drew 7 Amps for a period of 5 hours, the battery will have supplied 35 AH. The approximate recharge time would then be calculated by dividing the 35 AH depleted from the battery, by the ampere charge rate of the charger. To allow for tapering of the charge rate add 25 percent to the charge time.

OPERATING INSTRUCTIONS

- * **BLINKING RED LIGHT** - Indicates AC power is on, battery not connected.
- * **CONTINUOUS RED LIGHT** - Indicates AC power is on, battery connected.
- * **CONTINUOUS GREEN LIGHT** - Indicates correct connection. If when battery is connected, the green light does not light, check for proper polarity or poor connections. If the battery voltage is below 2 volts the green light will not come on.
- * **BLINKING GREEN LIGHT** - Indicates charge is complete.
- * **CONTINUOUS YELLOW LIGHT** - Indicates charging.
- * **ALTERNATING GREEN AND YELLOW LIGHTS** - Flooded batteries only. Indicates first stage of deep discharge recovery process.
- * **ALL THREE LIGHTS CONTINUOUS ON** - Indicates charging stopped, weak battery detected.
- * **DIGITAL DISPLAY** - Indicates battery type, FLOODED or SEALED, battery VOLTAGE and CHARGE RATE, from 15 to 6 while charging. Indicates SULFATED while in the deep discharge recovery mode. Indicates REMOVE BATTERY when charge is complete. Indicates WEAK BATTERY if charging stopped because the battery is not accepting charge or tests unsatisfactory after charging.

NOTES:

FOUR SECOND DELAY - To avoid sparking, the charger tests for correct polarity before applying current to the battery. When connected properly, the green light will come on for 4 seconds before the yellow light comes on.

DEEP DISCHARGE RECOVERY - If the charger determines a battery is deeply discharged, it will attempt to recover the battery with a program designed to enhance charge acceptance. Because of the high voltage levels required for recovery, this program is not included for sealed batteries.

VRLA BATTERIES - All sealed batteries are valve regulated batteries. They will be of two types, gel cell or absorptive glass mat (AGM). VRLA batteries have voltage limit restrictions during charging to prevent gassing because their sealed construction prevents replenishing the electrolyte. Never charge a sealed battery with the selector switch in the FLOODED position.

MANUAL START SWITCH - For safety reasons, the charger is designed to have zero output voltage if there is no battery connected to the clamps. Therefore, to begin charging, at least 2.0 volts must be present at the clamps. In order to recover batteries discharged below 2.0 volts, the MANUAL START momentary switch has been provided. Output is turned full on when the switch is pressed and stays on until the switch is released. Hold the switch down until the voltage reading on the display reads between 7 and 10 volts, then release the switch. Several attempts may be required before auto charging will begin.

!! CAUTION !!

Connecting a battery in reverse polarity and pressing the MANUAL START switch could result in damage to the charger and a battery explosion. Always double check battery connections before pressing the MANUAL START switch. If possible, verify with a volt meter that the battery is below 2 volt before pressing the switch. If sparking results, immediately release the switch. Refer to IMPORTANT SAFETY INSTRUCTIONS portion of this manual.

OPERATING PROCEDURE:

1. Put selector switch in the position which matches the type of battery being charged.
2. Plug AC cord into outlet. Turn POWER switch ON. Red light will blink and the display will read BATTERY VOLTAGE 00.000
3. Connect the BLACK clamp to the negative (-) and the RED clamp to the positive (+). The GREEN light will come on for 4 seconds and the display will read the voltage of the battery. See PREPARING TO CHARGE portion under IMPORTANT SAFETY INSTRUCTIONS of this manual.
4. The YELLOW light will come on when the GREEN light goes off and charging will begin. The voltage, battery type and charge rate will show on the digital display.
5. When in FLOODED battery charging, if the battery is deeply discharged, the YELLOW and GREEN lights will alternate on and off for about 1 minute. The digital display will indicate SULFATED mode charging.
6. Charging will be discontinued if the battery will not accept charge after a reasonable amount of time. The digital display will indicate WEAK BATTERY and all 3 lights will be continuously on.
7. Charging time will depend on the size and state of charge of the battery. A limit of 60 minutes for normal batteries and 70 minutes for deeply discharged batteries has been set.
8. When charging is complete, a beeper will sound and the digital display will indicate REMOVE BATTERY. The GREEN light will blink.
9. If the final battery test after charge indicates the battery is not satisfactory, the beeper will sound and the digital display will read BATTERY WEAK.

NOTES ON RECOVERY OF DEEPLY DISCHARGED BATTERIES:

- a. Not all deeply discharged batteries can be recovered.
- b. Most weak batteries will be detected while charging. However, some batteries which have been recovered from a deep discharge will maintain an acceptable open circuit voltage but have a reduced capacity under load. Always load test or otherwise test a recovered battery to determine if the CCA capacity is within 80% of the rated value.
- c. Some large deeply discharged batteries may be recovered, but are not recharged enough in the 70 minute maximum charge time to be put back into service. Either put it on a suitable finish charger, such as AEC Model 9410 or 9420, or allow battery to cool and charge again on this charger.

WIRING DIAGRAM

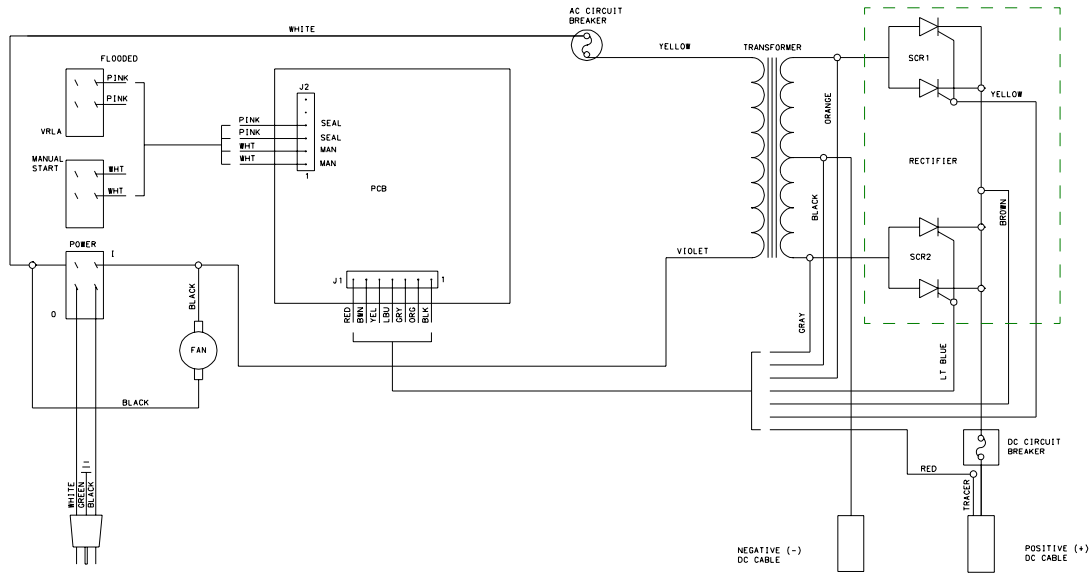

**M
6003 REPAIR PARTS**

ODEL

Item	Description	Part No.
1	Front Leg	605183
2	Axle w/nuts	610052
3	Wheel w/nuts	610849
4	Rectifier w/wiring harness	610948
5	Transformer	610949
6	Fan Blade	610189
7	Fan Motor w/blade	610190
8	AC Circuit Breaker	610920
9	DC Circuit Breaker	610536
10	Switch (Flooded/Seal or On/Off), qty. 1	610918
11	Switch (Manual Start), qty. 1	610954
12	AC Cord	610951
13	Side Terminal Adapter (qty. 1)	610181
14	DC Cable Positive	610952
15	DC Cable Negative	610953
16	Clamps (1 pair w/jaws)	6202
17	Jaw Kit (repairs 1 clamp)	6204
18	PCB	610950

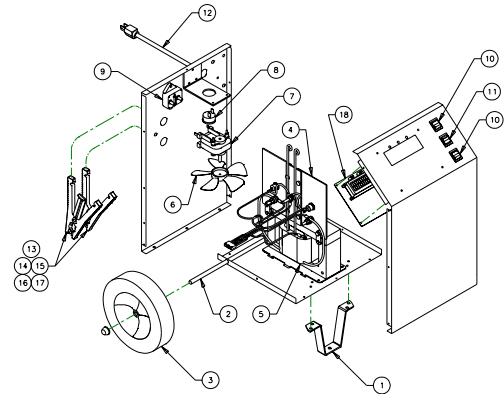

MAINTENANCE INSTRUCTIONS

Worn clamps should be replaced. Worn parts can lead to poor connections and present a safety hazard. See parts list for part number of D.C. Cord kit. Any Maintenance or repair of this unit that involves disassembly of the cabinet should be done only by a qualified serviceman. Incorrect reassembly may result in a risk of electric shock when the unit is subsequently used.

ILLUSTRATION LISTING 27-681E.MAN 6003 - ENGLISH

FIG.	FILE	FILE-DWG	DESCRIPTION
1	loge.eps		ASSOCIATED LOGO
2	PLUG-ENG.PLT	PLUG_ENG.DWG	GROUNDING ADAPTER - ENGLISH
3	27-681.PLT	27-681.DWG	ASSEMBLY,HANDLE, LEGS AND WHEELS
3	27-681WE.PLT	27-681W.DWG	WIRING DIAGRAM 6003 - ENGLISH
4	27-681A.PLT	27-681A.DWG	EXPLODED VIEW 6003