

DAD-500™ DESICCANT AIR DRYER SYSTEM

Avoid Costly Redo's

- Properly maintained air filtration system eliminates moisture and dirt in air lines
- Install at point of use



Order No.	Model No.	Description
130026	DAD-500	3-stage desiccant air dryer system



Compare DeVilbiss filtered air vs. unfiltered air

DeVilbiss' DAD-500 filters out contaminants to .01 micron



Compare the humidity reading before and after filtering with DeVilbiss DAD-500

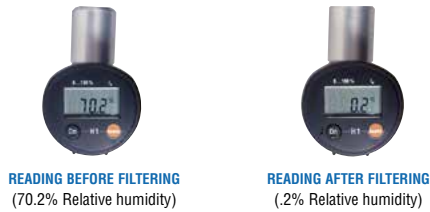

Refer to Service Bulletin: SB-6-156

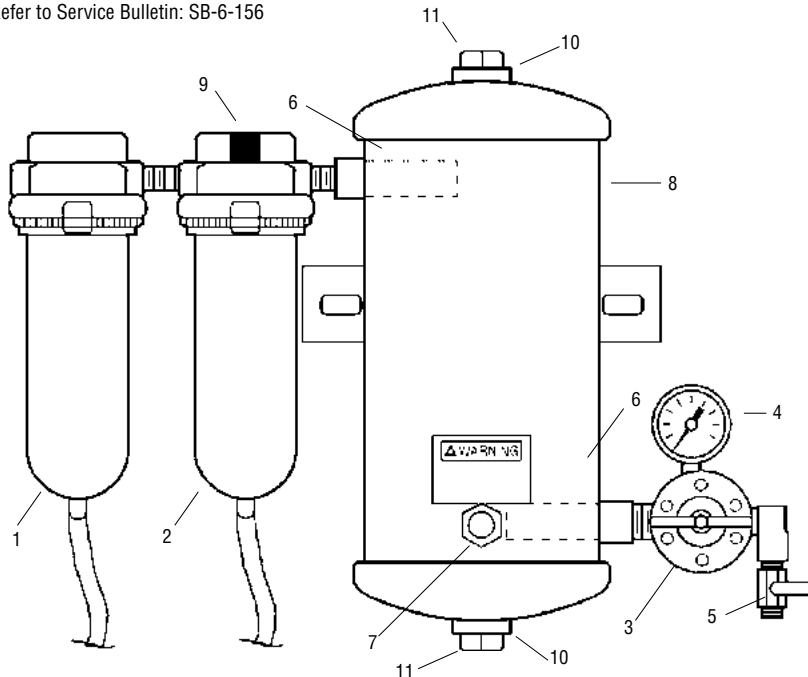

Ref. Order No.	Model No.	Description	Ind. Parts Req.
1	130041	Water Separator Filter	1
2	130027	Oil Coalescing Filter	1
3	130059	Air Regulator	1
4	190564	Gauge	1
5	240039	Ball Valve	1
6	190953	DAD-8 Air Filter (inside of tank)	2
7	190895	DAD-400 Humidity Indicator (paper included)	1
8	190877	PT-417 Desiccant Tank (without desiccant) (incl. #6)	1
9	190883	HAF-404 Filter Change Indicator	1
+	190831	DAD-1 Desiccant Refill	1
+	190727	HAF-6 Filter (see Key Maintenance Items chart)	1
+	190845	HAF-28 Filter (see Key Maintenance Items chart)	1
10	802153	SSG-8217-K2 O Ring Kit	1
11	802154	PT-96 Pipe Plug special 1-1/2 NPT	2
12	801288	VA-595 Brass Shut Off Valve (not shown)	1

+ Key Maintenance Items (Replace periodically for efficient performance)

Order No.	Model No.	Description
190831	DAD-1	Desiccant Refill
190727	HAF-6	First stage water separator filter element (5 micron)
190845	HAF-28	Second stage coalescing filter element (.01 micron)

SPECIFICATIONS:

13-0041 (HAF-502) Water Separator Filter

Air Inlet & Air Outlet ½" NPT(F)
 Air Flow Capacity 100 CFM
 Max. Operating Pressure 150 PSIG (10.3 Bar)
 Max. Temp. 150°F (65.6°C)
 Automatic Drain Standard
 Filter 5 micron

HAF-505 Oil Coalescing Filter

Air Inlet & Air Outlet ½" NPT(F)
 Air Flow Capacity 55 CFM
 Max. Operating Pressure 150 PSIG (10.3 Bar)
 Max. Temperature 150°F (65.6°C)
 Automatic Mechanical Drain Standard
 Pressure Differential Indicator Standard
 Filter 0.01 micron

Desiccant Dryer

Air Inlet & Air Outlet ½" NPT(F)
 Air Flow Capacity 25 CFM
 Max. Operating Pressure 150 PSIG (10.3 Bar)
 Max. Temperature 150°F (65.6°C)
 Humidity Indicator Standard
 Water Vapor Removal -40°F Dew Point

HAR-507 Air Regulator

Air Inlet ¾" NPT(F)
 Air Outlet ¼" NPT(F) (3 each)
 Air Flow 60 CFM
 Max. Operating Pressure 150 PSIG (10.3 Bar)
 Max. Temperature 120°F (48.9°C)

VA-595 Main Air Supply Shut Off Valve (not shown)

Air Inlet & Air Outlet ½" NPT(M)
 Max. Operating Pressure 175 PSIG (12.0 Bar)

Shipping Weight DAD-500: 35 lbs

Dimensions DAD-500: 22" x 17" x 18"

• Tune-Up Kit 130030 (DAD-600)

Model No.	Description	Qty.
DAD-1	Desiccant Refill	1
HAF-6	Filter Element for 13-0041	1

• Tune-Up Kit 802182 (DAD-600-1)

Model No.	Description	Qty.
DAD-1	Desiccant Refill	1
HAF-6	Filter Element for 13-0041	1
HAF-28	Filter Element for HAF-505	1