

# TEKNA® Clearcoat

## THE NEW STANDARD FOR CLEARCOAT APPLICATION



**Includes:**

- TE25 (High Efficiency) and HV30 (HVLV) air caps
- Multiple fluid tips
- Digital Gauge with air adjusting valve (HAV-555)
- Gun wrench and color ID rings



Waterborne compatible when using a plastic or disposable cup system.



Order No.	Fluid Tips	Cup	Air Caps
704198	1.2, 1.3 & 1.4mm	Uncupped	TE25 (HE) & HV30 (HVLV)

\* Uncupped guns include disposable cups adapter

### TEKNA® Clearcoat Air Caps

<b>TE25 air cap (HE)</b>	<b>Suitable for all types of clearcoats</b> Air Cap Order/Model No. <b>704200</b> 11 – 13 CFM @ 22 – 29 PSI inlet	<b>Air Cap Pattern</b> <b>12-13"</b>
<b>HV30 air cap (HVLV)</b>	<b>Clearcoats</b> Air Cap Order/Model No. <b>703540</b> 13 – 15 CFM @ 20 – 24 PSI inlet	<b>Air Cap Pattern</b> <b>13-14"</b>
<b>Fluid Tips</b>	1.2mm, 1.3mm, 1.4mm, 1.5mm	



Refer to Technical Bulletin: TB-1026

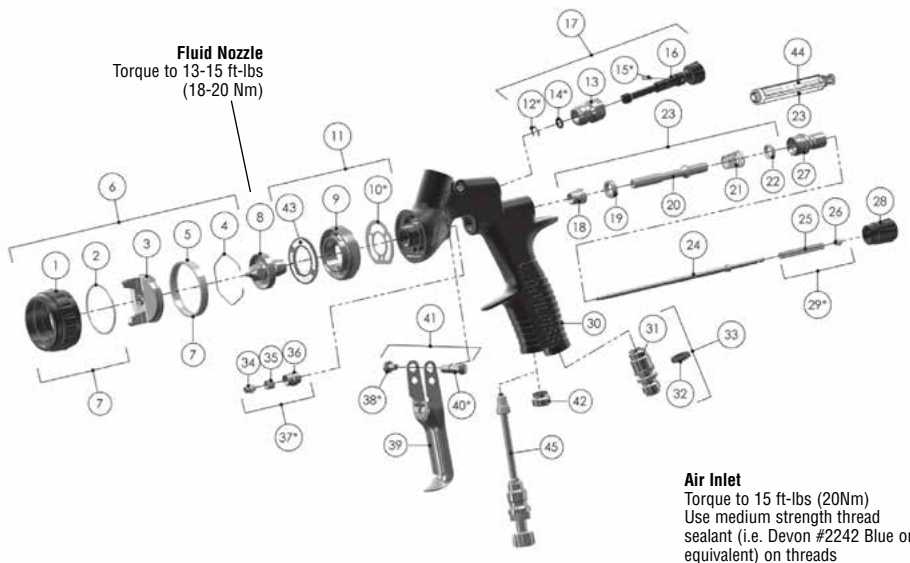

### CHART 1 Air Cap Replacement Parts

Air Cap Order No.	Application	Air Cap No.	Recommended Inlet Pressure BAR/PSI	Air Flow LPM/SCFM
704200	Clearcoats	TE25	1.5–2.0 bar 22–29 psi	311 – 368 LPM 11 – 13 SCFM
704206	Clearcoats	HV30	1.4–1.6 bar 20–24 psi	368 – 424 LPM 13 – 15 SCFM

### CHART 2 Fluid Nozzles

Fluid Nozzle Order No.	No. on Fluid Nozzle	Tip Size (mm)
703521	PRO-200-12	1.2
703522	PRO-200-13	1.3
703523	PRO-200-14	1.4
703589	PRO-200-15	1.5

### SERVICE PARTS

Spray Gun repair kit (includes items marked *)	703536
Seal and Pin Kit, kit of 5 (items 12, 14 and 15)	192229

Ref #	Description	Part #	Qty
1	Air Cap Retaining Ring		1
2	Slip Ring		1
3	Air Cap		1
4	Air Cap Retaining Clip	191972	1
5	Retaining Ring Seal		1
6	Aircap & Ring	Chart 1	1
7	Air Cap Retaining Ring & Seals	703896	1
8	Fluid Nozzle	Chart 2	1
9	Spray head		1
*10	Spray head Seal	702726	1
11	Spray head kit	703529	1
*12	Circlip		1
13	Valve Body		1
*14	O Ring		1
*15	Spreader Valve Pin		1
16	Spreader Valve Adjusting Knob		1
17	Spreader Valve Assembly	703898	1
18	Front Valve Seal		1
19	Valve Seat		1
20	Spindle		1
21	Air Valve Spring		1
22	Rear Valve Seal		1
23	Air Valve Kit	703530	1
24	Fluid Needle	Chart 2	1
25	Needle Spring		1
26	Spring Pad		1
27	Housing & Seal Kit	703532	1
28	Fluid Adjusting Knob	704163	1
*29	Needle Spring Kit	703534	1
30	Gunbody		1
31	Air Inlet		1
32	Colour ID Ring Kit (4 Colours)	702735	1
33	Air Inlet Kit	702734	1
34	Needle Packing		1
35	Packing Spring		1
36	Packing Nut		1
*37	Packing, Spring and Packing Nut Kit	702731	1
*38	Trigger Screw		1
39	Trigger		1
*40	Trigger Stud		1
41	Trigger Stud & Screw Kit	703535	1
42	Plug		1
43	Baffle Plate	704162	1
44	Air Valve Service Tool (only included in the Air Valve Kit 23)		1
45	Cheater Valve (optional)	704164	1

# TEKNA® Basecoat

## THE ULTIMATE BASECOAT SPRAY GUN



### Includes:

- HV20 HVLP Air Cap
- Extra needle/nozzle set
- Digital gauge with air adjusting valve (HAV-555)
- Gun wrench and color ID rings



Waterborne compatible when using a plastic or disposable cup system.



Order No.	Fluid Tips	Cup	Air Caps
703892*	1.2, 1.3mm	Uncupped	HV20 (HVLP)
703893*	1.3, 1.4mm	Uncupped	HV20 (HVLP)
703894	1.2, 1.3mm	900cc Aluminum	HV20 (HVLP)
703895	1.3, 1.4mm	900cc Aluminum	HV20 (HVLP)

\* Uncupped guns include disposable cups adapter

### TEKNA® Basecoat Air Caps

HV20 air cap (HVLP)	Solvent and waterborne basecoats	Air Cap Pattern
Air Cap Order/Model No	703899	12½"
Fluid Tips	11.2–13 CFM @ 14–18 PSI inlet	
Fluid Tips	1.2mm, 1.3mm, 1.4mm, 1.5mm	



Refer to Technical Bulletin: TB-1018

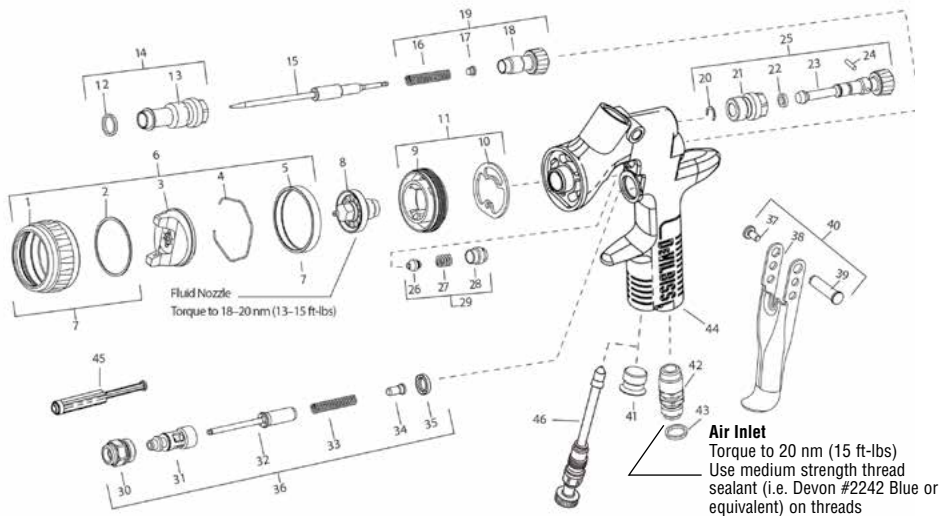

### CHART 1 Air Cap Replacement Parts

Air Cap Order No.	Application	Air Cap No.	Recommended Inlet Pressure BAR/PSI	Air Flow LPM/SCFM
703899	Basecoats	HV20	1.2–1.3 bar 14–18 psi	317–368 LPM 11.2–13.0 CFM

### CHART 2 Fluid Nozzles

Fluid Nozzle Order No.	No. on Fluid Nozzle	Tip Size (mm)
702711	SN-37-11	1.1
702712	SN-37-12	1.2
702713	SN-37-13	1.3
702714	SN-37-14	1.4
702715	SN-37-15	1.5

Wrench (10 & 14mm)	702740
Seal and Pin Kit, kit of 5 (items 20, 22 and 24)	192229

\* The TEKNA Spray Gun Repair Kit (702736) contains all the parts indicated with an asterisk.

Ref #	Description	Part #	Qty
1	Air Cap Retaining Ring		1
2	Slip Ring		1
3	Air Cap		1
4	Air Cap Retaining Clip	191972	1
5	Retaining Ring Seal		1
6	Air Cap & Ring	Chart 1	1
7	Air Cap Retaining Ring & Seals	703896	1
8	Fluid Nozzle	Chart 2	1
9	Air Separator		1
*10	Air Separator Seal (kit of 2)	702726	1
11	Air Separator & Seal Kit	703900	1
*12	Body Bushing Gasket		1
13	Body Bushing		1
14	Body Bushing & Gasket	702728	1
15	Fluid Needle	Chart 2	1
*16	Needle Spring		1
*17	Needle Spring Pad		1
18	Fluid Adjusting Knob		1
19	Fluid Adjusting Knob, Spring, & Pad Kit	703897	1
*20	Retaining Clip		1
21	Spreader Valve Body		1
*22	O-ring		1
23	Spreader Valve Adjusting Knob		1
*24	Spreader Valve Pin		1
25	Spreader Valve Assembly	703898	1
*26	Needle Packing		1
*27	Packing Spring		1
*28	Packing Nut		1
29	Packing, Spring & Packing Nut Kit	702731	1
30	Air Valve Body		1
31	Air Valve Cage		1
32	Air Valve Poppet		1
33	Air Valve Spring		1
34	Air Valve Spring Pad		1
35	Air Valve Seal		1
36	Air Valve Assembly	702732	1
*37	Trigger Stud Screw (T20 Star)		1
38	Trigger		1
*39	Trigger Stud		1
40	Trigger, Stud & Screw Kit	702733	1
41	Plug		1
42	Air Inlet	702734	1
43	Colour ID Ring Kit (4 Colours)	702735	1
44	Gun Body		1
45	Air Valve Service Tool (only included with Air Valve Assembly 36)		1
46	Air Adjusting Valve (optional)	702737	1

# TEKNA® Primer

## THE ULTIMATE IN PRIMER SPRAY GUN TECHNOLOGY



- Includes:**
- PR10 (High Efficiency) and PR30 (HVLV) Air Caps
  - 900cc Aluminum Cup
  - Gun wrench



Waterborne compatible when using a plastic or disposable cup system.



Order No.	Fluid Tips	Cup	Air Caps
704174	1.4, 1.6mm	900cc Aluminum	PR10 (HE) & PR30 (HVLV)
704175	1.8, 2.0mm	900cc Aluminum	PR10 (HE) & PR30 (HVLV)
704182	2.5mm	900cc Aluminum	PR10 (HE) & PR30 (HVLV)

### TEKNA® Primer Air Caps

<b>PR10 air cap (HE)</b>	<b>Primers including low VOC</b> Air Cap Order/Model No. <b>704165</b> 12.0 CFM @ 29.0 PSI inlet	<b>Air Cap Pattern</b> 10½"-12"
<b>PR30 air cap (HVLV)</b>	<b>Primers including low VOC</b> Air Cap Order/Model No. <b>704166</b> 16.0 CFM @ 21.0 PSI inlet	<b>Air Cap Pattern</b> 11-13"
<b>Fluid Tips</b>	1.4mm, 1.6mm, 1.8mm, 2.0mm, 2.5mm	

### Accessories (sold separately)

Order No.	Model No.	Description
704245	PRIPRO-219-UV1-K	UV1 Fluid Tip
704246	PRIPRO-219-UV2-K	UV2 Fluid Tip
704247	PRIPRO-319-K	UV Fluid Needle
704240	GFC-515	Black Polyester UV Gravity Cup
704241	PRO-46-K3	Protective Air Cap Cover (pack of 3)



Refer to Technical Bulletin: TB-1024

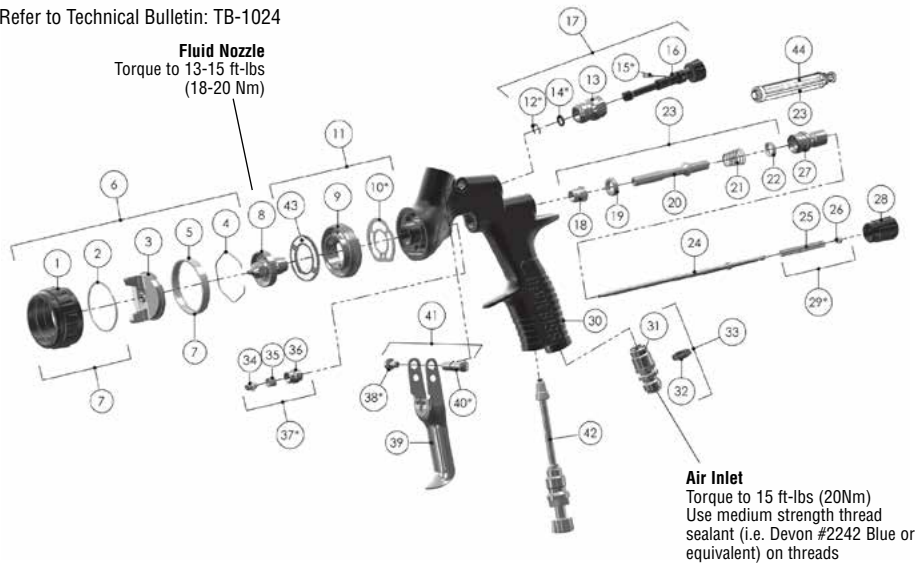

### CHART 1 Air Cap Replacement Parts

Air Cap Order No.	Application	Air Cap No.	Recommended Inlet Pressure BAR/PSI	Air Flow LPM/SCFM
704165	Primers, including low VOC	PR10	1.8-2.0 bar 26-29 psi	311 - 340 LPM 11 - 12 SCFM
704166	Primers, including low VOC	PR30	1.2-1.4 bar 17-21 psi	396 - 453 LPM 14 - 16 SCFM

### CHART 2 Fluid Nozzles

Fluid Nozzle Order No.	No. on Fluid Nozzle	Tip Size (mm)
704168	PRIPRO-220-14	1.4
704169	PRIPRO-220-16	1.6
704170	PRIPRO-220-18	1.8
704171	PRIPRO-220-20	2.0
704172	PRIPRO-220-25	2.5

### SERVICE PARTS

Spray Gun repair kit (includes items marked *)	703536
Seal and Pin Kit, kit of 5 (items 12, 14 and 15)	192229

Ref #	Description	Part #	Qty
1	Air Cap Retaining Ring		1
2	Slip Ring		1
3	Air Cap		1
4	Air Cap Retaining Clip	191972	1
5	Retaining Ring Seal		1
6	Aircap & Ring	Chart 1	1
7	Air Cap Retaining Ring & Seals	703896	1
8	Fluid Nozzle	Chart 2	1
9	Spray head		1
*10	Spray head Seal	702726	1
11	Spray head kit	703529	1
*12	Circlip		1
13	Valve Body		1
*14	O Ring		1
*15	Spreader Valve Pin		1
16	Spreader Valve Adjusting Knob		1
17	Spreader Valve Assembly	703898	1
18	Front Valve Seal		1
19	Valve Seat		1
20	Spindle		1
21	Air Valve Spring		1
22	Rear Valve Seal		1
23	Air Valve Kit	703530	1
24	Fluid Needle	Chart 2	1
25	Needle Spring		1
26	Spring Pad		1
27	Housing & Seal Kit	703532	1
28	Fluid Adjusting Knob	704163	1
*29	Needle Spring Kit	703534	1
30	Gunbody		1
31	Air Inlet		1
32	Colour ID Ring Kit (4 Colours)	702735	1
33	Air Inlet Kit	702734	1
34	Needle Packing		1
35	Packing Spring		1
36	Packing Nut		1
*37	Packing, Spring and Packing Nut Kit	702731	1
*38	Trigger Screw		1
39	Trigger		1
*40	Trigger Stud		1
41	Trigger Stud & Screw Kit	703535	1
42	Cheater Valve (optional)	702737	1
43	Baffle Plate	704162	1
44	Air Valve Service Tool (only included in the Air Valve Kit 23)		1

# TEKNA® ProLite BASECOAT/CLEARCOAT GRAVITY FEED SPRAY GUNS



**Includes:**

- HAV-555 air adjusting valve with digital gauge
- Gun wrench
- Color identification rings
- Additional fluid tips
- QuickClean™ coating

EPA and SCAQMD Approved

EPA Compliant. Approved in most HVLP areas.

Waterborne compatible when using a plastic or disposable cup system.

Order No.	Fluid Tips	Cup	Air Caps
703517*	1.3, 1.4, 1.5mm	Uncupped	TE20, HV30
703567*	1.2, 1.3, 1.4mm	Uncupped	TE10, TE20
703566	1.2, 1.3, 1.4mm	900cc Aluminum	TE10, TE20

\* Uncupped guns include disposable cups adapter

**TEKNA® ProLite Air Caps**

<b>HV30 air cap (HVLP)</b>	<b>Basecoats, clearcoats</b> Air Cap Order/Model No. <b>703540</b> 14.5-16.5 CFM @ 20-24 PSI inlet for HVLP approved areas	<b>Air Cap Pattern</b> 13-14"
<b>TE10 air cap (HE)</b>	<b>Basecoats, low solids clearcoats</b> Air Cap Order/Model No. <b>703538</b> 7.5-11.0 CFM @ 20-35 PSI inlet	<b>Air Cap Pattern</b> 12-13"
<b>TE20 air cap (HE)</b>	<b>Basecoats, high solids clearcoats</b> Air Cap Order/Model No. <b>703539</b> 9-12 CFM @ 16-26 PSI inlet	<b>Air Cap Pattern</b> 12-13"
<b>Fluid Tips</b>	1.2mm, 1.3mm, 1.4mm, 1.5mm	



Refer to Technical Bulletin: TB-1008

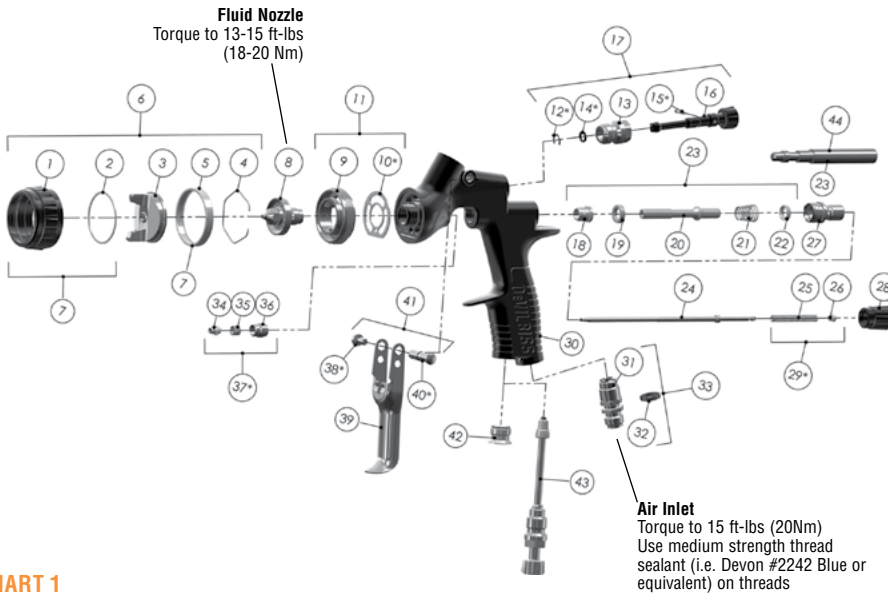

**CHART 1**  
Air Cap Replacement Parts

Air Cap Order No.	Application	Air Cap No.	Recommended Inlet Pressure BAR/PSI	Air Flow LPM/SCFM
703540	Basecoats Clearcoats	HV30	1.4-1.6 bar 20-24 psi	411-467 LPM 14.5-16.5 CFM
703538	Basecoats, low solids clearcoats	TE10	1.4-2.4 bar 20-35 psi	212-311 LPM 7.5-11.0 CFM
703539	Basecoats, high solids clearcoats	TE20	1.1-1.8 bar 16-26 psi	255-340 LPM 9-12 CFM

**CHART 2**  
Fluid Nozzles

Fluid Nozzle Order No.	No. on Fluid Nozzle	Tip Size (mm)
703521	PRO-200-12	1.2
703522	PRO-200-13	1.3
703523	PRO-200-14	1.4
703589	PRO-200-15	1.5

Ref #	Description	Part #	Qty
1	Air Cap Retaining Ring		1
2	Slip Ring		1
3	Air Cap		1
4	Air Cap Retaining Clip	191972	1
5	Retaining Ring Seal		1
6	Aircap & Ring	Chart 1	1
7	Air Cap Retaining Ring & Seals	702725	1
8	Fluid Nozzle	Chart 2	1
9	Spray head		1
*10	Spray head Seal	702726	1
11	Spray head kit	703529	1
*12	Circlip		1
13	Valve Body		1
*14	O Ring		1
*15	Spreader Valve Pin		1
16	Spreader Valve Adjusting Knob		1
17	Spreader Valve Assembly	702730	1
18	Front Valve Seal		1
19	Valve Seat		1
20	Spindle		1
21	Air Valve Spring		1
22	Rear Valve Seal		1
23	Air Valve Kit	703530	1
24	Fluid Needle	703531	1
25	Needle Spring		1
26	Spring Pad		1
27	Housing & Seal Kit	703532	1
28	Fluid Adjusting Knob	703533	1
*29	Needle Spring Kit	703534	1
30	Gunbody		1
31	Air Inlet		1
32	Colour ID Ring Kit (4 Colours)	702735	1
33	Air Inlet Kit	702734	1
34	Needle Packing		1
35	Packing Spring		1
36	Packing Nut		1
*37	Packing, Spring and Packing Nut Kit	702731	1
*38	Trigger Screw		1
39	Trigger		1
*40	Trigger Stud		1
41	Trigger Stud & Screw Kit	703535	1
42	Plug		1
43	Cheater Valve (optional)	702737	1
44	Air Valve Service Tool (only included in the Air Valve Kit 23)		1

**SERVICE PARTS**

Spray Gun repair kit (includes items marked *)	703536
Seal and Pin Kit, kit of 5 (items 12, 14 and 15)	192229

# TEKNA® Pro BASECOAT/CLEARCOAT GRAVITY FEED SPRAY GUNS



**Includes:**

- Multiple air caps and nozzles
- HAV-555 digital air adjusting valve with gauge
- Gun wrench and color ID rings
- Full-size gun body

EPA Compliant.  
Approved in most  
HVLV areas.

EPA and  
SCAQMD  
Approved

Waterborne  
Compatible

Waterborne compatible when using a plastic or disposable cup system.

Order No.	Fluid Tips	Cup	Air Caps
703582*	1.3, 1.4, & 1.5mm	Uncupped	TE20 & HV30
703581*	1.2, 1.3, & 1.4mm	Uncupped	TE10 & TE20
703580	1.2, 1.3, & 1.4mm	900cc Aluminum	TE10 & TE20

\* Uncupped guns include disposable cups adapter

**TEKNA® Pro Air Caps**

<b>TE10 air cap (HE)</b>	<b>Basecoats, low solids clearcoats</b> Air Cap Order/Model No. <b>703538</b> 7.5–11 CFM @ 20–35 PSI inlet	<b>Air Cap Pattern</b> 12-13"
<b>TE20 air cap (HE)</b>	<b>Basecoats, high solids clearcoats</b> Air Cap Order/Model No. <b>703539</b> 9–12 CFM @ 16–26 PSI inlet	<b>Air Cap Pattern</b> 12-13"
<b>HV30 air cap (HVLV)</b>	<b>Basecoats, clearcoats</b> Air Cap Order/Model No. <b>703540</b> 14.5–16.5 CFM @ 20–24 PSI inlet	<b>Air Cap Pattern</b> 13-14"
<b>Fluid Tips</b>	1.2mm, 1.3mm, 1.4mm, 1.5mm	



Refer to Technical Bulletin: TB-1012

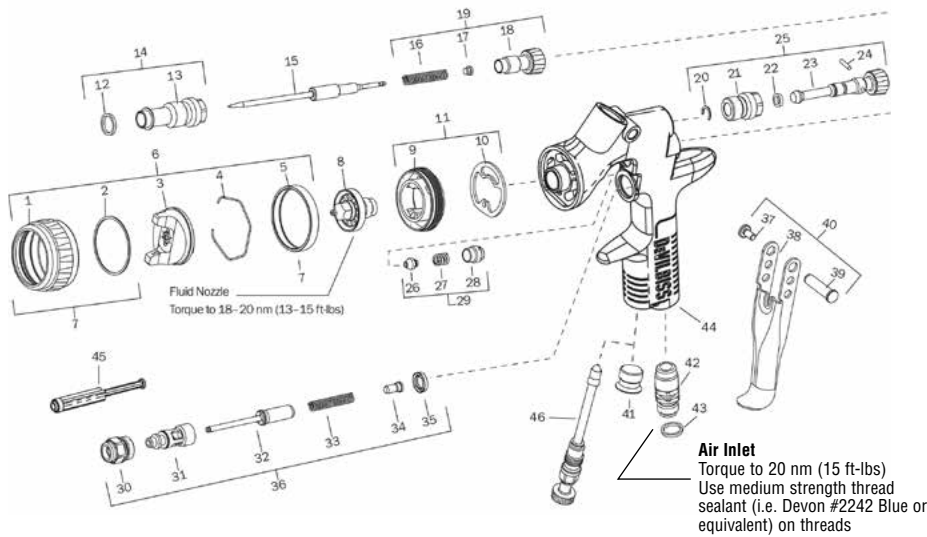

**CHART 1  
Air Cap Replacement Parts**

Air Cap Order No.	Application	Air Cap No.	Recommended Inlet Pressure BAR/PSI	Air Flow LPM/SCFM
703540	Basecoats Clearcoats	HV30	1.4–1.6 bar 20–24 psi	411–467 LPM 14.5–16.5 CFM
703538	Basecoats, low solids clearcoats	TE10	1.4–2.4 bar 20–35 psi	212–311 LPM 7.5–11.0 CFM
703539	Basecoats, high solids clearcoats	TE20	1.1–1.8 bar 16–26 psi	255–340 LPM 9–12 CFM

**CHART 2  
Fluid Nozzles**

Fluid Nozzle Order No.	No. on Fluid Nozzle	Tip Size (mm)
703521	PRO-200-12	1.2
703522	PRO-200-13	1.3
703523	PRO-200-14	1.4
703589	PRO-200-15	1.5

Wrench (10 & 14mm)	702740
Seal and Pin Kit, kit of 5 (items 20, 22 and 24)	192229

\* The TEKNA Spray Gun Repair Kit (702736) contains all the parts indicated with an asterisk.

Ref #	Description	Part #	Qty
1	Air Cap Retaining Ring		1
2	Slip Ring		1
3	Air Cap		1
4	Air Cap Retaining Clip	191972	1
5	Retaining Ring Seal		1
6	Air Cap & Ring	Chart 1	1
7	Air Cap Retaining Ring & Seals	702725	1
8	Fluid Nozzle	Chart 2	1
9	Air Separator		1
*10	Air Separator Seal (kit of 2)	702726	1
11	Air Separator & Seal Kit	703529	1
*12	Body Bushing Gasket		1
13	Body Bushing		1
14	Body Bushing & Gasket	702728	1
15	Fluid Needle	Chart 2	1
*16	Needle Spring		1
*17	Needle Spring Pad		1
18	Fluid Adjusting Knob		1
19	Fluid Adjusting Knob, Spring, & Pad Kit	702729	1
*20	Retaining Clip		1
21	Spreader Valve Body		1
*22	O-ring		1
23	Spreader Valve Adjusting Knob		1
*24	Spreader Valve Pin		1
25	Spreader Valve Assembly	702730	1
*26	Needle Packing		1
*27	Packing Spring		1
*28	Packing Nut		1
29	Packing, Spring & Packing Nut Kit	702731	1
30	Air Valve Body		1
31	Air Valve Cage		1
32	Air Valve Poppet		1
33	Air Valve Spring		1
34	Air Valve Spring Pad		1
35	Air Valve Seal Seal (Kit of 5)	803307	1
36	Air Valve Assembly	702732	1
*37	Trigger Stud Screw (T20 Star)		1
38	Trigger		1
*39	Trigger Stud		1
40	Trigger, Stud & Screw Kit	702733	1
41	Plug		1
42	Air Inlet	702734	1
43	Colour ID Ring Kit (4 Colours)	702735	1
44	Gun Body		1
45	Air Valve Service Tool (only included with Air Valve Assembly 36)		1
46	Air Adjusting Valve (optional)	702737	1

# TEKNA® Copper HE BASECOAT/CLEARCOAT GRAVITY FEED SPRAY GUNS



**Includes:**

- 7E7 high efficiency air cap
- HAV-555 air adjusting valve with digital gauge
- Extra needle/nozzle set
- Gun wrench and color ID rings

EPA and SCAQMD Approved

EPA Compliant. Approved in most HVLP areas.

Waterborne compatible when using a plastic or disposable cup system.

Order No.	Needle/Nozzle	Cup	Air Cap
703675*	1.2mm, 1.3mm	Uncupped	7E7
703676	1.2mm, 1.3mm	900cc Aluminum	7E7
703661*	1.3mm, 1.4mm	Uncupped	7E7
703662	1.3mm, 1.4mm	900cc Aluminum	7E7

\* Uncupped guns include disposable cups adapter

**TEKNA® Copper HE Air Caps**

Air Cap	Description	Air Cap Pattern
#7E7 air cap (HE)	<b>Basecoats, clearcoats</b> Air Cap Order/Model No. <b>703062</b> 9–11 CFM @ 16–22 PSI inlet for HVLP approved areas	12½"
#202 air cap (HVLP)	<b>Basecoats (solvent)</b> Air Cap Order/Model No. <b>702723</b> 13.5–15.5 CFM @ 18–22 PSI inlet	13"
#909 air cap (HVLP)	<b>Clearcoats, waterborne basecoats</b> Air Cap Order/Model No. <b>702724</b> 14–16 CFM @ 22–26 PSI inlet	12"
<b>Fluid Tips</b>	1.1mm, 1.2mm, 1.3mm, 1.4mm, 1.5mm (for hot climate waterborne)	



Refer to Technical Bulletin: TB-1016

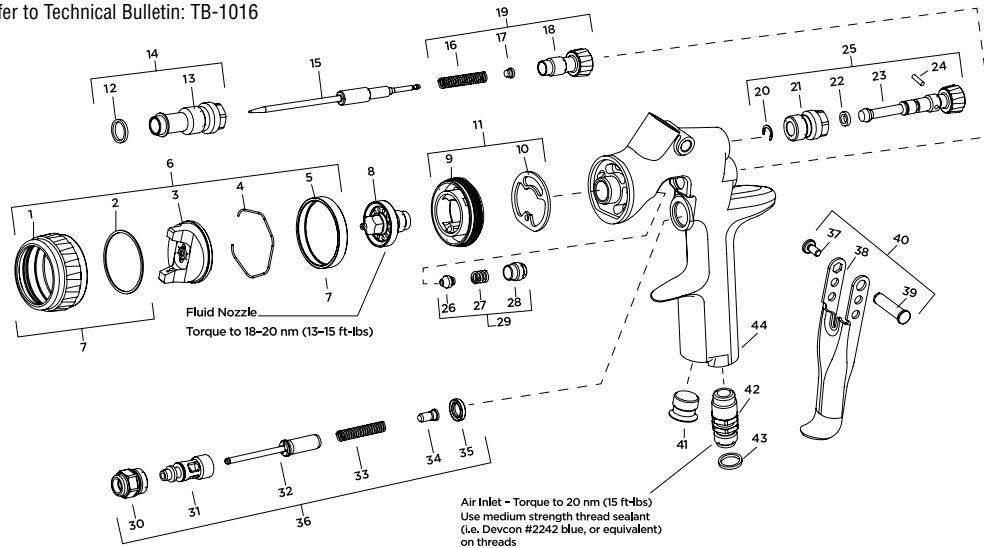

**CHART 1: Fluid Nozzle & Fluid Needle Replacement Parts**

Fluid Nozzle Size I.D. (mm)	Fluid Nozzle/Needle Set No.	NOTE:
1.1	702711	When replacing the fluid nozzle or fluid needle, replace both at the same time. Lightly lubricate the threads of the fluid nozzle before reassembling. Torque 14–16 nm (10–12 ft-lbs). Don't over tighten the fluid nozzle. Use 10mm wrench supplied with gun.
1.2	702712	
1.3	702713	
1.4	702714	
1.5	702715	

**CHART 2: Air Cap Replacement Parts**

Air Cap Order No.	Application	Air Cap No.	Recommended Inlet Pressure BAR/PSI	Air Flow LPM/SCFM
702723	Basecoats	#202 HVLP	1.2–1.5 BAR/18–22 PSI	382–434 LPM 13.5–15.5 SCFM
702724	Clearcoats Waterborne Base	#909 HVLP	1.5–1.8 BAR/22–26 PSI	396–453 LPM 14–16 SCFM
703062	Basecoats, clearcoats	#7E7 HE	1.1–1.5 BAR/16–22 PSI (HVLP approved areas) 1.5–2.0 BAR/22–30 PSI (non-HVLP approved areas)	255–312 LPM/9–11 SCFM 312–368 LPM/11–13 SCFM (non-HVLP approved areas)

Ref. No.	Description	Part No.	Qty
1	Air Cap Retaining Ring		1
2	Slip Ring		1
3	Air Cap		1
4	Air Cap Retaining Clip	191972	1
5	Retaining Ring Seal		1
6	Air Cap & Ring (see Chart 2)		1
7	Air Cap Retaining Ring & Seals	702725	1
8	Fluid Nozzle (see Chart 2)		1
9	Air Separator		1
*10	Air Separator Seal (kit of 2)	702726	1
11	Air Separator & Seal Kit	702727	1
*12	Body Bushing Gasket		1
13	Body Bushing		1
14	Body Bushing & Gasket	702728	1
15	Fluid Needle (see Chart 1)		1
*16	Needle Spring		1
*17	Needle Spring Pad		1

Ref. No.	Description	Part No.	Qty
18	Fluid Adjusting Knob		1
19	Fluid Adjusting Knob, Spring, & Pad Kit	702729	1
*20	Retaining Clip		1
21	Spreader Valve Body		1
*22	O-ring		1
23	Spreader Valve Adjusting Knob		1
*24	Spreader Valve Pin		1
25	Spreader Valve Assembly	702730	1
*26	Needle Packing		1
*27	Packing Spring		1
28	Packing Nut		1
29	Packing, Spring & Packing Nut Kit	702731	1
30	Air Valve Body		1
31	Air Valve Cage		1
32	Air Valve Poppet		1
33	Air Valve Spring		1
34	Air Valve Spring Pad		1
35	Air Valve Seal (kit of 5)	803307	1
36	Air Valve Assembly	702732	1
*37	Trigger Stud Screw (T20 Star)		1
38	Trigger		1
*39	Trigger Stud		1
40	Trigger, Stud & Screw Kit	702733	1
41	Plug		1
42	Air Inlet	702734	1
43	Colour ID Ring Kit (4 Colours)	702735	1
44	Gun Body		1

\* The TEKNA Spray Gun Repair Kit (702736) contains all the parts indicated with an asterisk.

**OTHER SALABLE PARTS /ACCESSORIES**

Wrench (10 & 14mm)	702740
#202 Test Cap (HVLP)	702738
#909 Test Cap (HVLP)	702739
Spray Gun Repair Kit	702736
TEKNA Replacement 900cc Aluminum Cup	702576
Disposable Lid Kit (2)	GFC-404-K2
Paint Filter Kit	KGP-5-K5

# PLUS® HIGH EFFICIENCY GRAVITY FEED GUN

# PLUS®

### Includes:

- 1.2mm, 1.3mm, and 1.4mm fluid tips
- 900cc aluminum cup with push-on lid
- HAV-511 high output air adjusting valve with gauge
- Fluid filter, gun hook

Order No.	Model No.	Type	Fluid Tip (mm)	Inlet Pressure	Application
110264	GFG-670	HE	1.2, 1.3	25–35 PSI	Basecoats
				30–40 PSI	High solids clearcoats
			1.4	30–40 PSI	Single stages
				30–40 PSI	Low solids clearcoats
			30–40 PSI	Single stages	

### PLUS® Gravity Feed High Efficiency Air Cap

#410 air cap	Primers, basecoats, clearcoats, single stage and low VOC	Air Cap Order No. <b>192174</b> Air Cap Model No. <b>AV-440-410</b> 30–40 PSI Inlet 9–11 CFM	Air Cap Pattern 12½"
Fluid tips	1.0mm, 1.2mm, 1.3mm, 1.4mm (Included tip sizes shown in bold)		



EPA Compliant.  
Approved in most  
HVLPA areas.

Refer to Service Bulletin: SB-2-194

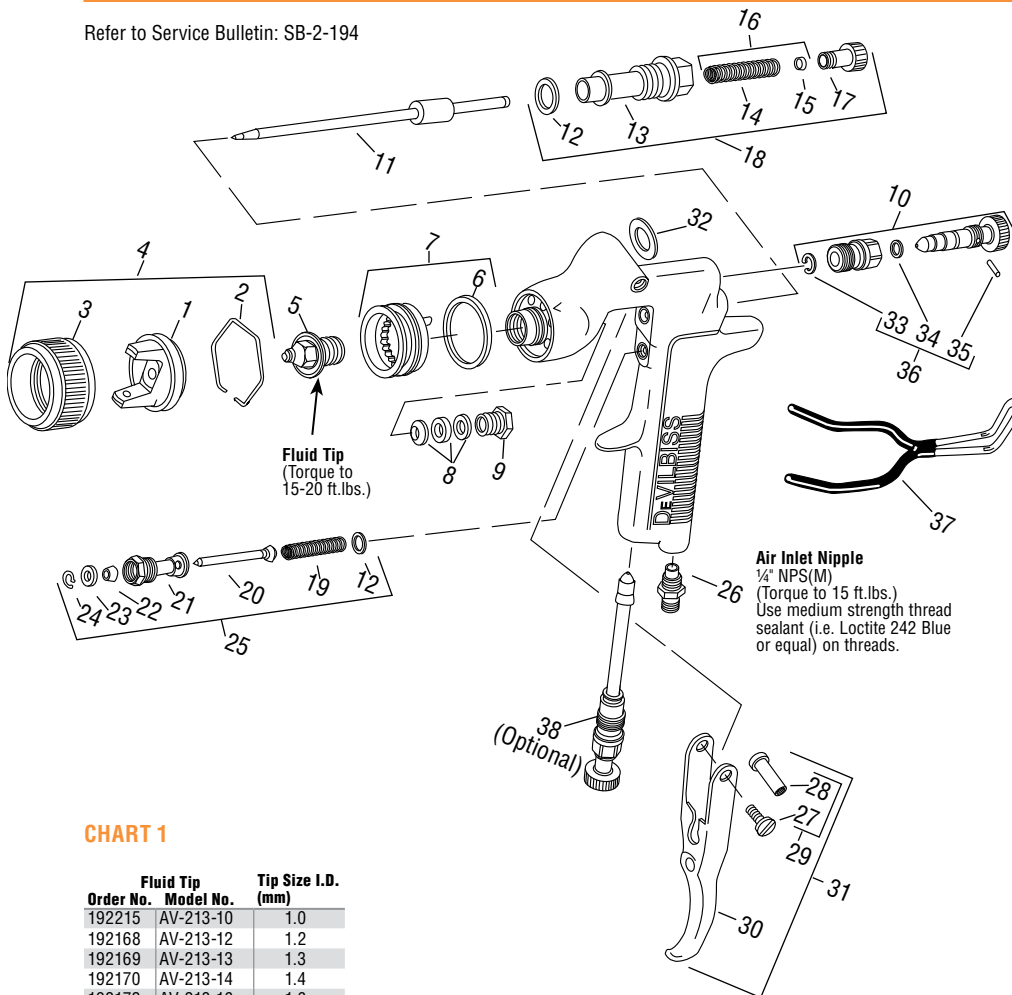

### CHART 1

Fluid Tip	Tip Size I.D.	
Order No.	Model No.	(mm)
192215	AV-213-10	1.0
192168	AV-213-12	1.2
192169	AV-213-13	1.3
192170	AV-213-14	1.4
192172	AV-213-16	1.6
192173	AV-213-18	1.8

Ref. No.	Order No.	Model No.	Description	Ind. Parts Req.
1	—	—	#410 Air Cap	1
2	191972	JGA-156-K10	Spring Clip (Kit of 10)	1
3	192042	GTI-3	Air Cap Retaining Ring	1
4	192174	AV-440-410	#410 Air Cap and Retaining Ring	1
5	See Chart 1	See Chart 1	Fluid Tip	1
•6	192179	GTI-33-K5	Baffle Seal (Kit of 5)	1
7	192178	GTI-425	Baffle Assembly	1
•8	192109	JGA-4035-K5	Packing (Kit of 5)	1
9	190893	34411-122-K10	Packing Nut	1
10	192050	GTI-404	Spreader Valve	1
11	192054	GTI-413	Fluid Needle	1
•12	190161	JGS-72-K10	Gasket Kit (PTFE) (Kit of 10)	2
13	—	—	Body Bushing	1
•14	—	—	Fluid Needle Spring	1
•15	—	—	Spring Pad	1
16	190894	MBD-19-K10	Spring and Pad (Kit of 10)	1
17	192043	GTI-414	Needle Adjusting Screw	1
18	192139	KK-5059	Bushing, Spring, Pad and Knob Kit	1
•19	—	—	Air Valve Spring	1
•20	—	—	Air Valve	1
21	—	—	Air Valve Body	1
•22	—	—	U Cup Seal	1
•23	—	—	Washer	1
•24	—	—	Snap Ring	1
25	190780	JGS-449-1	Air Valve Assembly	1
26	190287	P-MB-51	Air Inlet Nipple 1/4" NPS(M)	1
27	—	—	Trigger Stud Screw	1
28	—	—	Trigger Stud	1
29	190889	JGS-478	Stud and Screw Kit	1
30	—	—	Trigger	1
31	191943	JGS-477-1	Trigger Stud, Screw Kit	1
•32	192151	KGP-13-K5	Cup Gasket (Kit of 5)	1
•33	—	—	Retaining Clip	1
•34	—	—	Seal	1
•35	—	—	Pin	1
36	192229	GTI-428-K5	Clip, Seal & Pin Kit (5 Each)	1
37	192219	—	Gun Holder, Coated	1
38	192228	GTI-415	Air Adjusting Valve (Optional)	1

The 192227 Spray Gun Repair Kit contains all the parts indicated with a •

# GTi® Millennium HVLV GRAVITY FEED GUN/CUP



**Includes:**

- 1.3mm, 1.4mm, and 1.5mm fluid tips
- 900cc aluminum cup with push-on lid
- HAV-511 high output air adjusting valve with gauge
- Fluid filter, gun hook

Order No.	Model No.	Type	Fluid Tip (mm)	Inlet Pressure	Application
170156	GTI-620G	HVLV	1.3, 1.4	20–25 PSI	Basecoats
				25–30 PSI	High solids clearcoats, single stages
			1.5	20–25 PSI	Basecoats
				25–30 PSI	Low solids clearcoats, single stages

**GTi® Millennium Gravity Feed HVLV Air Cap**

#2000 air cap HVLV	Basecoats, clearcoats, primers, single stage, and low VOC	Air Cap Order No. <b>192136</b> Air Cap Model No. <b>GTI-407-2000</b> 20–30 PSI inlet 12.5-16.0 CFM	Air Cap Pattern 12"
Fluid tips	1.2mm, <b>1.3mm</b> , <b>1.4mm</b> , <b>1.5mm</b> , 1.6mm, 1.8mm, 2.0mm, 2.2mm (Included tip sizes shown in bold)		

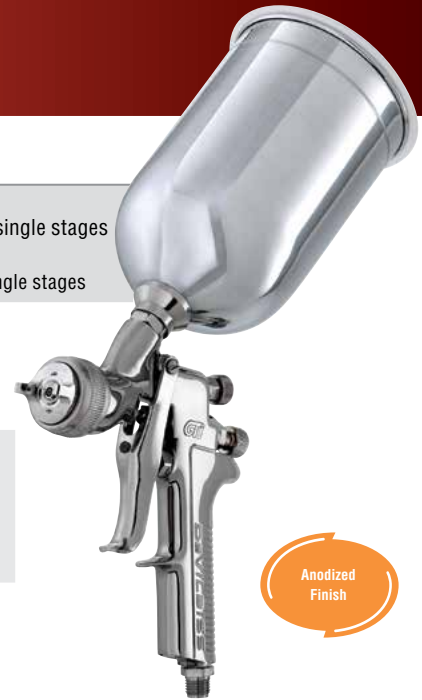

Anodized Finish

Refer to Service Bulletin: SB-2-168

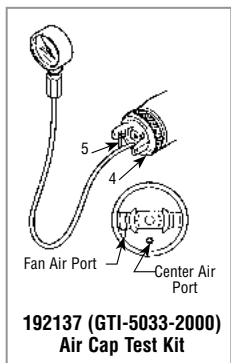
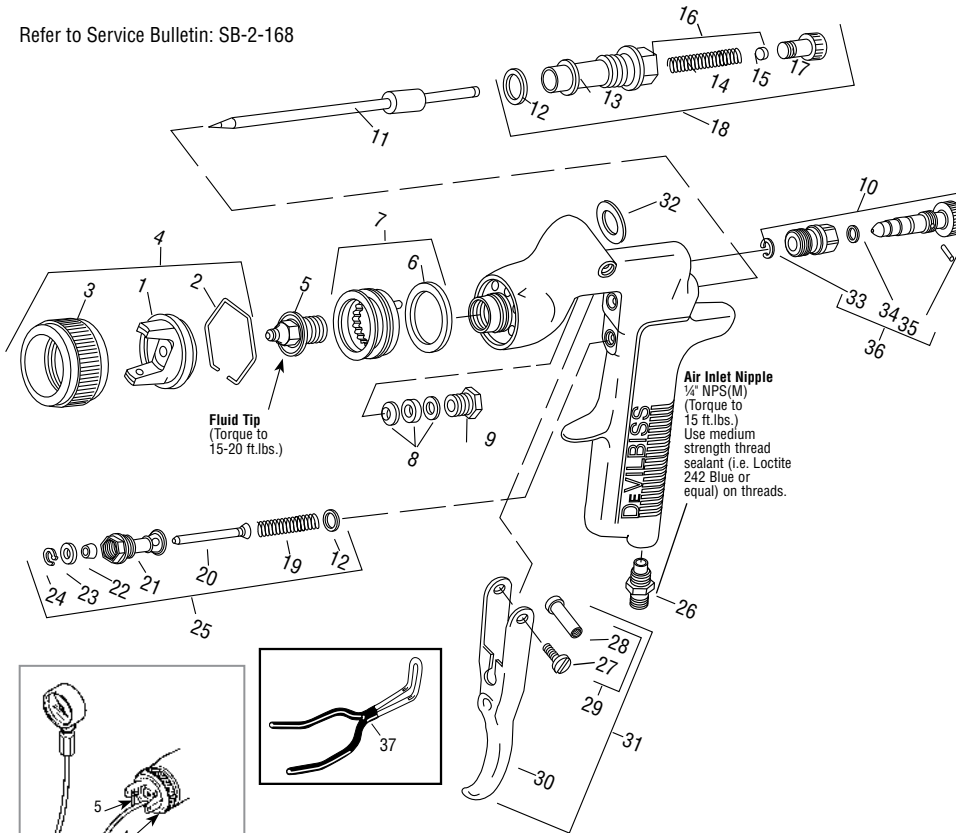

**CHART 1**

Order No.	Fluid Tip Model No.	Tip Size I.D. (mm)
192124	GTI-213-12	1.2
192134	GTI-213-13	1.3
192044	GTI-213-14	1.4
192135	GTI-213-15	1.5
192045	GTI-213-16	1.6
192046	GTI-213-18	1.8
192047	GTI-213-20	2.0
192132	GTI-213-22	2.2

Ref. No.	Order No.	Model No.	Description	Ind. Parts Req.
1	—	—	Air Cap	1
2	191972	JGA-156-K10	Spring Clip (Kit of 10)	1
3	192042	GTI-3	Air Cap Retaining Ring	1
4	192136	GTI-407-2000	Air Cap (#2000) and Retaining Ring	1
5	See Chart 1	See Chart 1	Fluid Tip	1
•6	192179	GTI-33-K5	Baffle Seal (Kit of 5)	1
7	192178	GTI-425	Baffle Assembly	1
•8	192109	JGA-4035-K5	Packing (Kit of 5)	1
9	190893	34411-122-K10	Packing Nut	1
10	192050	GTI-404	Spreader Valve	1
11	192054	GTI-413	Fluid Needle	1
•12	190161	JGS-72-K10	Gasket Kit (PTFE) (Kit of 10)	2
13	—	—	Body Bushing	1
•14	—	—	Fluid Needle Spring	1
•15	—	—	Spring Pad	1
16	190894	MBD-19-K10	Spring and Pad (Kit of 10)	1
17	192043	GTI-414	Needle Adjusting Screw	1
18	192139	KK-5059	Bushing, Spring, Pad and Knob Kit	1
•19	—	—	Air Valve Spring	1
•20	—	—	Air Valve	1
21	—	—	Air Valve Body	1
•22	—	—	U Cup Seal	1
•23	—	—	Washer	1
•24	—	—	Snap Ring	1
25	190780	JGS-449-1	Air Valve Assembly	1
26	190287	P-MB-51	Air Inlet Nipple 1/4\" NPS(M)	1
27	—	—	Trigger Stud Screw	1
28	—	—	Trigger Stud	1
29	190889	JGS-478	Stud and Screw Kit	1
30	—	—	Trigger	1
31	191943	JGS-477-1	Trigger Stud, Screw Kit	1
•32	192151	KGP-13-K5	Cup Gasket (Kit of 5) Blue	1
•33	—	—	Retaining Clip	1
•34	—	—	Seal	1
•35	—	—	Pin	1
36	192229	GTI-428-K5	Clip, Seal & Pin Kit (5 Each)	1
37	192219	—	Gun Holder, Coated	1
38	192140	KK-5060	Air Cap Cleaning Kit	1

• A quantity of necessary parts is included in 192227 Repair Kit (KK-5058-2) for complete gun repair and should be kept on hand for service convenience.

**Suffixes:** -K5 designates kit of multiple parts. Example: JGA-4035-K5 is a kit of 5 packings.



# JGA® CONVENTIONAL SUCTION FEED GUN/CUP

- Includes:**
- TGC 1 qt. cup

## Proven Technology and Durability

Order No.	Model No.	Type	Fluid Tip (mm)	Inlet Pressure	Application
110225	JGA-644	CNV.	1.6	35-50 PSI	Base, clear, low VOC, single stages, Urethanes
110102	JGA-636	CNV.	1.8	25-45 PSI	Synthetic and acrylic enamels. May need to restrict fluid flow with needle adjustment for base and clearcoats.

CNV. = CONVENTIONAL

## JGA® Conventional Suction Feed Air Caps

<b>#9000 air cap</b>	<b>Basecoats, clearcoats, single stages</b>	<b>Air Cap Order No. 199000</b>	<b>Air Cap Pattern 10"</b>
	Air Cap Model No. AV-440-9000	35-50 PSI inlet	
	Fluid tips	1.6mm, 1.8mm	
<b>#80 air cap</b>	<b>Synthetic and acrylic enamels</b>	<b>Air Cap Order No. 190230</b>	<b>Air Cap Pattern 12"</b>
	Air Cap Model No. MB-4039-80	25-45 PSI inlet	
	Fluid tips	10-14 CFM	
		1.8mm	



Refer to Technical Bulletin: SB-2-259

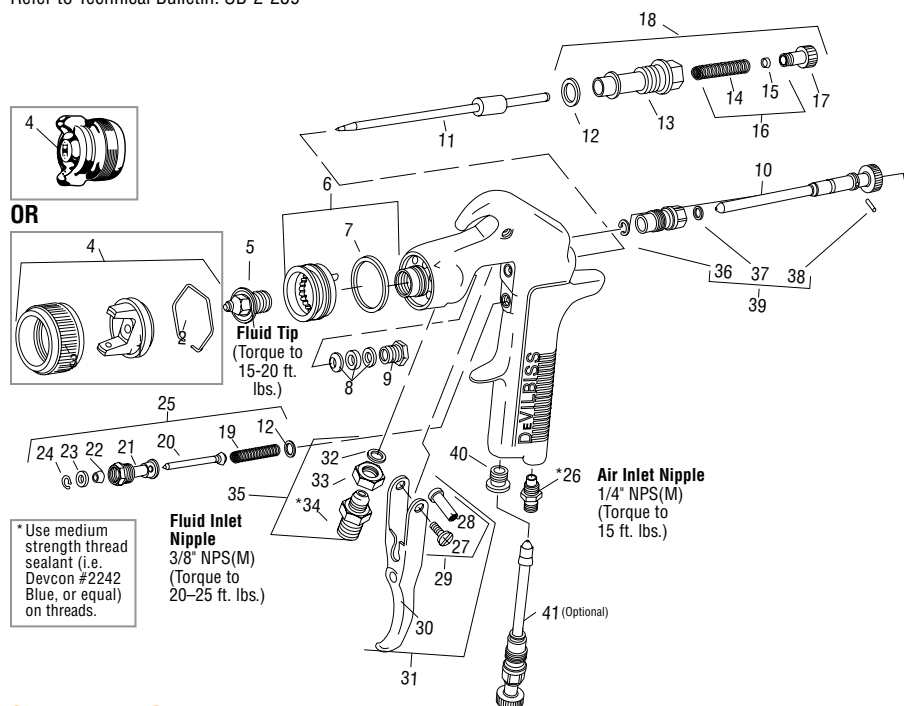

**CHART 1 – Air Caps, Fluid Tips, Fluid Needles & Applications**

No. on Air Cap Order No. →	Air Cap With Ring (Ref. No. 4)	Type of Fluid Delivery	Fluid Needle (Ref. No. 11)	Fluid Tips Used (Ref. No. 5)
80	190230 MB-4039-80	Suction	192054 GTI-413	AV-213-16 OR AV-213-18
9000	199000 AV-440-9000	Suction OR Pressure	192054 GTI-413	AV-213-16 OR AV-213-18

**CHART 2 – Fluid Tips**

Fluid Tip Order No.	Model No.	Tip Size I.D. (mm)	Type of Fluid Delivery
192172	AV-213-16	1.6	Suction Feed
192173	AV-213-18	1.8	Suction Feed

Ref. No.	Order No.	Model No.	Description	Ind. Parts Req.
1	—	—	Air Cap	1
2	191972	JGA-156-K10	Spring Clip (Kit of 10)	1
3	192042	GTI-3	Air Cap Retaining Ring	1
4	—	See Chart 1	Air Cap & Retaining Ring	1
5	—	See Charts 1 & 2	Fluid Tip	1
6	192178	GTI-425	Baffle Assembly	1
7	192179	GTI-33-K5	Baffle Seal (Kit of 5)	1
8	192109	JGA-4035-K5	Packing (Kit of 5)	1
9	190893	34411-122-K10	Packing Nut (Kit of 10)	1
10	192051	GTI-405	Spreader Valve Assembly	1
11	—	See Chart 1	Fluid Needle	1
12	190161	JGS-72-K10	Gasket (PTFE) (Kit of 10)	2
13	—	—	Body Bushing	1
14	—	—	Fluid Needle Spring	1
15	—	—	Spring Pad	1
16	190894	MBD-19-K10	Spring & Pad (Kit of 10)	1
17	192043	GTI-414	Needle Adjusting Screw	1
18	192139	KK-5059	Bushing, Spring, Pad & Knob Kit	1
19	—	—	Air Valve Spring	1
20	—	—	Air Valve	1
21	—	—	Air Valve Body	1
22	—	—	U Cup Seal	1
23	—	—	Washer	1
24	—	—	Snap Ring	1
25	190780	JGS-449-1	Air Valve Assembly	1
26	190287	P-MB-51	Air Inlet Nipple 1/4" NPS(M)	1
27	—	—	Trigger Stud Screw	1
28	—	—	Trigger Stud	1
29	190889	JGS-478	Stud & Screw Kit (includes 3 Studs & 5 Screws)	1
30	—	—	Trigger	1
31	191943	JGS-477-1	Trigger, Stud & Screw Kit	1
32	—	—	Fluid Inlet Gasket (PTFE)	1
33	—	—	Locknut	1
34	—	—	Fluid Inlet Adapter	1
35	190888	JGA-4042	Fluid Inlet, Gasket & Nut Kit	1
36	—	—	Retaining Clip	1
37	—	—	Seal	1
38	—	—	Pin	1
39	192229	GTI-428-K5	Clip, Seal & Pin Kit (5 Each)	1
40	190828	JGA-132	Plug	1
41	192228	GTI-415	Air Adjusting Valve (Optional)	1

\* A quantity of necessary parts is included in 192227 Repair Kit (KK-5058-2) for complete gun repair and should be kept on hand for service convenience.

**Suffixes:** -K5 designates kit of multiple parts. Example: JGA-4035-K5 is a kit of 5 packings.

# TEKNA® ProLite

## HIGH EFFICIENCY/HVLP PRESSURE FEED GUN



**Includes:**

- Multiple air caps and fluid tips
- HAV-512 analog gauge
- Gun wrench and color ID rings
- Lightweight ergonomic design

EPA Compliant. Approved in most HVLP areas.

EPA and SCAQMD Approved



Waterborne compatible when using a plastic or disposable cup system.

Order No.	Fluid Tips	Air Cap
703663	1.0, 1.2, 1.4mm	TE40 & HV40

**TEKNA® ProLite Pressure Feed Air Caps**

Air Cap (HE)	Low to medium solids coatings	Air Cap Pattern
<b>TE20</b>	<b>Low to medium solids coatings</b> Air Cap Order No. <b>703539</b> Air Cap Model No. <b>PRO-103-TE20</b> 12–19 CFM @ 26–50 PSI inlet	<b>13-14"</b>
<b>TE40</b>	<b>Low to high solids coatings</b> Air Cap Order No. <b>703626</b> Air Cap Model No. <b>PRO-103-TE40</b> 13–19 CFM @ 29–50 PSI inlet	<b>12-13"</b>
<b>HV40</b>	<b>Low to high solids coatings</b> Air Cap Order No. <b>703621</b> Air Cap Model No. <b>PRO-103-HV40</b> 10.5 CFM @ 17 PSI inlet	<b>12-13"</b>
<b>Fluid Tips</b>	1.0mm, 1.2mm, 1.4mm	



Refer to Technical Bulletin: TB-1014

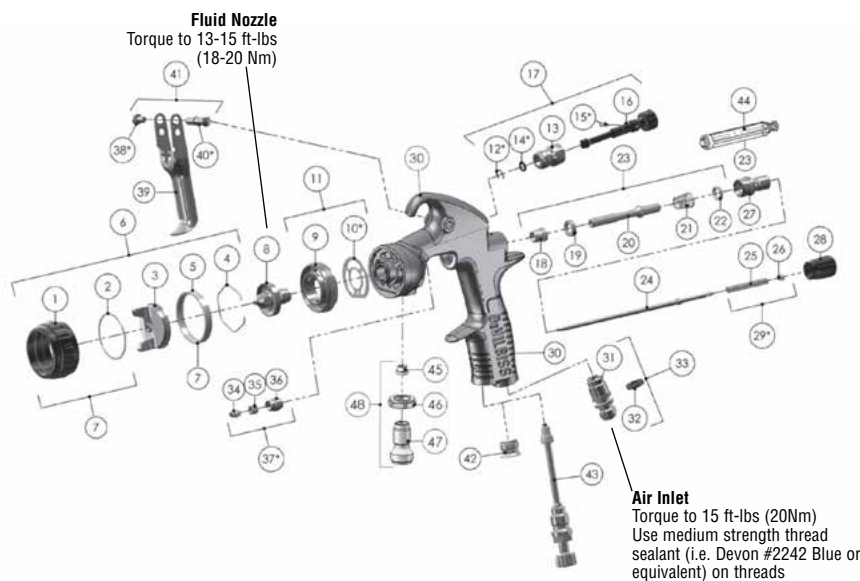

**CHART 1**  
Air Cap Replacement Parts

Air Cap Order No.	Application	Air Cap No.	Recommended Inlet Pressure BAR/PSI	Air Flow LPM/SCFM
703539	Low to medium solids coatings	TE20	1.8–3.4 bar 26–50 psi	340–538 LPM 12–19 CFM
703626	Low to high solids coatings	TE40	2.0–3.4 bar 29–50 psi	368–538 LPM 13–19 CFM
703621	Low to medium solids coatings	HV40	1.2 bar 17 psi	297 LPM 10.5 CFM

**CHART 2**  
Fluid Nozzles

Fluid Nozzle Order No.	No. on Fluid Nozzle
703627	PRO-205-10

**SERVICE PARTS**

Spray Gun repair kit (includes items marked *)	703536
Seal and Pin Kit, kit of 5 (items 12, 14 and 15)	192229

Ref #	Description	Part #	Qty
1	Air Cap Retaining Ring		1
2	Slip Ring		1
3	Air Cap		1
4	Air Cap Retaining Clip	191972	1
5	Retaining Ring Seal		1
6	Aircap & Ring	Chart 1	1
7	Air Cap Retaining Ring & Seals	702725	1
8	Fluid Nozzle	Chart 2	1
9	Spray head		1
*10	Spray head Seal	702726	1
11	Spray head kit	703529	1
*12	Circlip		1
13	Valve Body		1
*14	O Ring		1
*15	Spreader Valve Pin		1
16	Spreader Valve Adjusting Knob		1
17	Spreader Valve Assembly	703630	1
18	Front Valve Seal		1
19	Valve Seat		1
20	Spindle		1
21	Air Valve Spring		1
22	Rear Valve Seal		1
23	Air Valve Kit	703530	1
24	Fluid Needle	Chart 2	1
25	Needle Spring		1
26	Spring Pad		1
27	Housing & Seal Kit	703532	1
28	Fluid Adjusting Knob	703533	1
*29	Needle Spring Kit	703534	1
30	Gunbody		1
31	Air Inlet		1
32	Colour ID Ring Kit (4 Colours)	702735	1
33	Air Inlet Kit	702734	1
34	Needle Packing		1
35	Packing Spring		1
36	Packing Nut		1
*37	Packing, Spring and Packing Nut Kit	702731	1
*38	Trigger Screw		1
39	Trigger		1
*40	Trigger Stud		1
41	Trigger Stud & Screw Kit	703535	1
42	Plug		1
43	Cheater Valve (optional)	702737	1
44	Air Valve Service Tool (only included in the Air Valve Kit 23)		1
45	Seal		1
46	Lock Nut		1
47	Fluid Inlet		1
48	Fluid Inlet Kit	703631	1

# GTi® Millennium HVLV PRESSURE FEED GUN



## HVLV Technology with Large Spray Pattern

- Smooth material and air flow
- Easy to clean
- Produce a high gloss finish and minimize orange peel
- Excellent fluid control for applying more film build with fewer passes

Order No.	Model No.	Fluid Tip (mm)	Inlet Pressure	Application	Fluid Flow
170165	GTI-546P-14	1.4	50 PSI	High solids	9–12 oz./min.

## GTi® Millennium Pressure Feed HVLV Air Caps

<b>#2000 air cap (HVLV)</b>	<b>Primers, basecoats, clearcoats, and low VOC</b> Air Cap Order No. <b>192136</b> Air Cap Model No. <b>GTI-407-2000</b> 20–30 PSI inlet 12.5–16.0 CFM	<b>Air Cap Pattern</b> <b>11"</b>
<b>#46MP air cap (HVLV)</b>	<b>Primers, basecoats, clearcoats, single stages and low VOC</b> Air Cap Order No. <b>192184</b> Air Cap Model No. <b>GTI-407-46MP</b> 50 PSI inlet 22.5 CFM	<b>Air Cap Pattern</b> <b>12"</b>
<b>Fluid tips</b>	1.1mm, 1.4mm	



Refer to Service Bulletin: SB-2-199

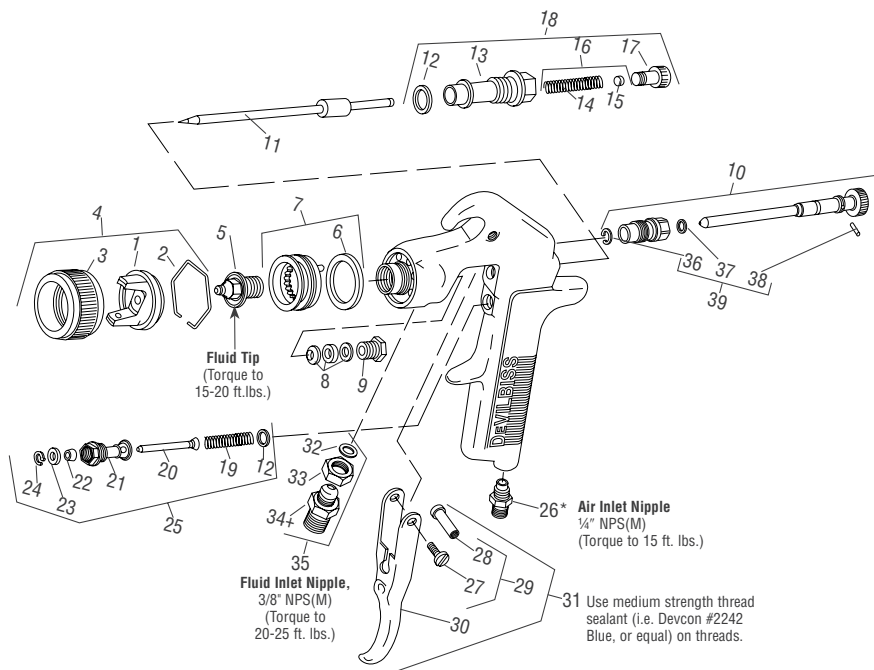

CHART 1: Air Cap and Baffle Combinations

Air Cap Part No.	Baffle	Set		CFM@ Cap Pressure				
		Ref. No. 4 Air Cap	Ref. No. 7 Baffle Assy.	2 PSI	4 PSI	6 PSI	8 PSI	10 PSI
2000	(Not Stamped)	GTI-407-2000	GTI-425	7.3	10.4	12.8	14.7	16.5
46MP	46	GTI-407-46MP	*JGPV-401-46-50	8.5	13.0	16.5	19.8	22.5

NOTE: Baffle Seal NOT used with GTI-546P gun (46MP air cap).

CHART 2: Fluid Tip and Needle

If this no. is on needle, order →	If this no. is on tip, order →	Order Matched Fluid Tip and Needle Assembly	Tip Size I.D. (mm)
JGA-402-FF	AV-2120-FF	JGA-4045-FF	1.4
JGA-402-FX	AV-2120-FX	JGA-4045-FX	1.1

● 192227 (KK-5058-2) Gun Repair Kit includes a quantity of necessary parts.

Suffixes: -K5 designates kit of multiple parts. Example: JGA-4035-K5 is a kit of 5 packings.

Ref. No.	Order No.	Model No.	Description	Ind. Parts Req.
1	—	—	Air Cap	1
2	191972	JGA-156-K10	Spring Clip (Kit of 10)	1
3	192042	GTI-3	Air Cap Retaining Ring	1
4	See Chart 1	—	Air Cap and Retaining Ring	1
5	See Chart 2	—	Fluid Tip	1
●6	192179	GTI-33-K5	Baffle Seal (Kit of 5)	1
7	See Chart 1	—	Baffle Assembly	1
●8	192109	JGA-4035-K5	Packing (Kit of 5)	1
9	190893	34411-122-K10	Packing Nut	1
10	192051	GTI-405	Spreader Valve	1
11	See Chart 2	—	Fluid Needle	1
●12	190161	JGS-72-K10	Gasket Kit (PTFE) (Kit of 10)	2
13	—	—	Body Bushing	1
●14	—	—	Fluid Needle Spring	1
●15	—	—	Spring Pad	1
16	190894	MBD-19-K10	Spring and Pad (Kit of 10)	1
17	192043	GTI-414	Needle Adjusting Screw	1
18	192139	KK-5059	Bushing, Spring, Pad & Knob Kit	1
●19	—	—	Air Valve Spring	1
●20	—	—	Air Valve	1
21	—	—	Air Valve Body	1
●22	—	—	U Cup Seal	1
●23	—	—	Washer	1
●24	—	—	Snap Ring	1
25	190780	JGS-449-1	Air Valve Assembly	1
+26	190287	P-MB-51	Air Inlet Nipple 1/4" NPS(M)	1
27	—	—	Trigger Stud Screw	1
28	—	—	Trigger Stud	1
29	190889	JGS-478	Stud and Screw Kit	1
30	—	—	Trigger	1
31	191943	JGS-477-1	Trigger Stud, Screw Kit	1
●32	—	—	Fluid Inlet Gasket (PTFE)	1
33	—	—	Locknut	1
+34	—	—	Fluid Inlet Adapter	1
35	190888	JGA-4042	Fluid Inlet, Gasket, Nut Kit	1
●36	—	—	Retaining Clip	1
●37	—	—	Seal	1
●38	—	—	Pin	1
39	192229	GTI-428-K5	Clip, Seal & Pin (Kit of 5 Each)	1

**PLUS®**  
HIGH EFFICIENCY PRESSURE FEED GUN



Anodized Finish

Order No.	Model No.	Air Cap	Fluid Tip (mm)	Inlet Pressure	Application	Fluid Flow
110272	PLUS-514P-12	#414 (HE)	1.2	60-65 PSI	High solids	7-14 oz./min.

**PLUS® Pressure Feed High Efficiency Air Caps**

<b>#414 air cap (HE)</b>	<b>High solids</b>			<b>Air Cap Pattern 11-14"</b>
	Air Cap Order No.	192312		
	Air Cap Model No.	AV-440-414		
		60-65 PSI inlet	19-22 CFM	
		Fluid tip 1.2mm		
<b>Fluid Tips</b>	1.0mm, 1.2mm, 1.3mm, 1.4mm			

Refer to Service Bulletin: SB-2-475

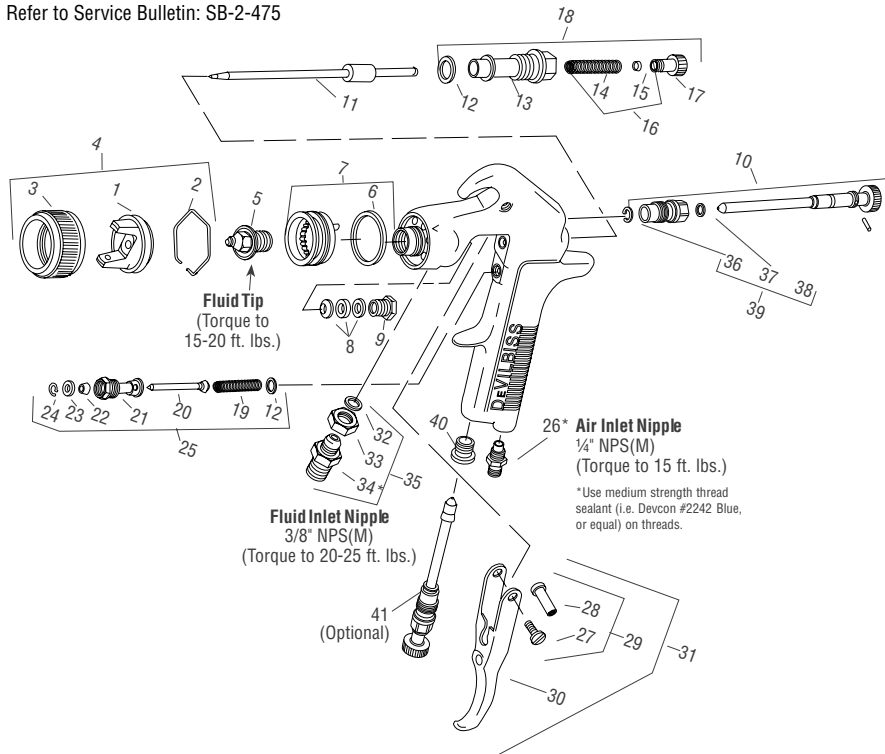

**CHART 1: Air Cap**

No. on Air Cap	Air Cap Order No.	Air Cap Model No.
410	192174	AV-440-410
414	192312	AV-440-414

**CHART 2: Fluid Tips and Needles**

Tip Size (mm)	Fluid Tip (Ref. No. 5)	Suction Feed Fluid Needle (Ref. No. 11)	Pressure Feed Fluid Needle (Ref. No. 11)
1.0	AV-213-10	NR	GTI-449-12
1.2	AV-213-12	NR	GTI-449-12
1.4	AV-213-14	GTI-413	GTI-449-12
1.6	AV-213-16	GTI-413	NR
1.8	AV-213-18	GTI-413	NR

NR = Not Recommended

●192227 (KK-5058-2) Gun Repair Kit includes a quantity of necessary parts.

Ref. No.	Order No.	Model No.	Description	Ind. Parts Req.
1	—	—	Air Cap	1
2	191972	JGA-156-K10	Spring Clip (Kit of 10)	1
3	192042	GTI-3	Air Cap Retaining Ring	1
4	—	See Chart 1	Air Cap and Retaining Ring	1
5	—	See Chart 2	Fluid Tip	1
●6	192179	GTI-33-K5	Baffle Seal (Kit of 5)	1
7	192178	GTI-425	Baffle Assembly	1
●8	192109	JGA-4035-K5	Packing (Kit of 5)	1
9	190893	34411-122-K10	Packing Nut	1
10	192051	GTI-405	Spreader Valve	1
11	—	See Chart 2	Fluid Needle	1
●12	190161	JGS-72-K10	Gasket Kit (PTFE) (Kit of 10)	2
13	—	—	Body Bushing	1
●14	—	—	Fluid Needle Spring	1
●15	—	—	Spring Pad	1
16	190894	MBD-19-K10	Spring and Pad (Kit of 10)	1
17	192043	GTI-414	Needle Adjusting Screw	1
18	192139	KK-5059	Bushing, Spring, Pad and Knob Kit	1
●19	—	—	Air Valve Spring	1
●20	—	—	Air Valve	1
21	—	—	Air Valve Body	1
●22	—	—	U Cup Seal	1
●23	—	—	Washer	1
●24	—	—	Snap Ring	1
25	190780	JGS-449-1	Air Valve Assembly	1
26	190287	P-MB-51	Air Inlet Nipple 1/4" NPS(M)	1
27	—	—	Trigger Stud Screw	1
28	—	—	Trigger Stud	1
29	190889	JGS-478	Stud and Screw Kit	1
30	—	—	Trigger	1
31	191943	JGS-477-1	Trigger Stud, Screw Kit	1
●32	—	—	Fluid Inlet Gasket (PTFE)	1
33	—	—	Locknut	1
34	—	—	Fluid Inlet Adapter	1
35	190888	JGA-4042	Fluid Inlet, Gasket, Nut Kit	1
●36	—	—	Retaining Clip	1
●37	—	—	Seal	1
●38	—	—	Pin	1
39	192229	GTI-428-K5	Clip, Seal & Pin (Kit of 5 Each)	1
40	190828	JGA-132	Plug	1
41	192228	GTI-415	Air Adjusting Valve (Optional)	1

**JGA®**  
CONVENTIONAL PRESSURE FEED GUN



High Production,  
High Performance

Worldwide choice  
for large area  
refinishing



Order No.	Model No.	Type	Fluid Tip (mm)	Inlet Pressure	Application	Fluid Flow
110274	JGA-504-777-14	CONV.	1.4	50-80 PSI	High solids fleet materials	9-17 oz./min.

CONV. = Conventional

**JGA® Conventional Pressure Feed Air Cap**

#777 air cap	<b>High solids</b>	<b>Air Cap Pattern</b> 11-14"
	Air Cap Order No. <b>192066</b>	
	Air Cap Model No. <b>AV-440-777</b>	
	50-80 PSI inlet Fluid tip 1.4mm	

Refer to Service Bulletin: SB-2-259

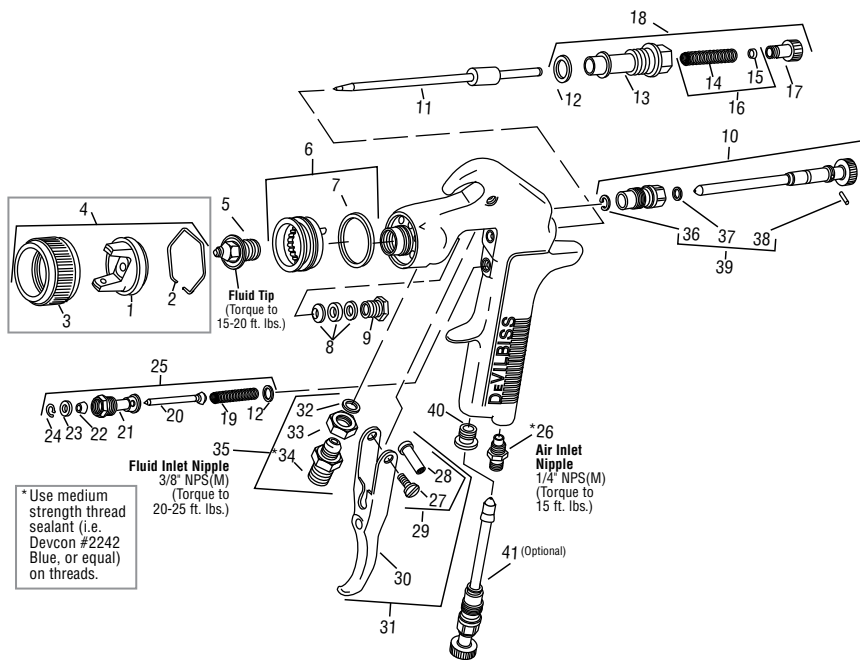

\* Use medium strength thread sealant (i.e. Devcon #2242 Blue, or equal) on threads.

**CHART 1: Air Caps, Fluid Needles & Fluid Tips**

If this no. is on air cap, order →	Air Cap with Ring (Ref. No. 4)	Fluid Needle (Ref. No. 11)	Fluid Tips Used (Ref. No. 5)
765	192310 AV-440-765	192311 GTI-449-12	192168 AV-213-12
777	192066 AV-440-777	192311 GTI-449-12	192170 AV-213-14

● A quantity of necessary parts is included in 192227 Repair Kit (KK-5058-2) for complete gun repair and should be kept on hand for service convenience.

**Suffixes:** -K5 designates kit of multiple parts. Example: JGA-4035-K5 is a kit of 5 packings.

Ref. No.	Order No.	Model No.	Description	Ind. Parts Req.
1	—	—	Air Cap	1
2	191972	JGA-156-K10	Spring Clip (Kit of 10)	1
3	192042	GTI-3	Air Cap Retaining Ring	1
4	See Chart 1	—	Air Cap & Retaining Ring	1
5	See Chart 1	—	Fluid Tip	1
6	192178	GTI-425	Baffle Assembly	1
●7	192179	GTI-33-K5	Baffle Seal (Kit of 5)	1
●8	192109	JGA-4035-K5	Packing (Kit of 5)	1
9	190893	34411-122-K10	Packing Nut (Kit of 10)	1
10	192051	GTI-405	Spreader Valve Assy	1
11	See Chart 1	—	Fluid Needle	1
●12	190161	JGS-72-K10	Gasket (PTFE) (Kit of 10)	2
13	—	—	Body Bushing	1
●14	—	—	Fluid Needle Spring	1
●15	—	—	Spring Pad	1
16	190894	MBD-19-K10	Spring & Pad (Kit of 10)	1
17	192043	GTI-414	Needle Adjusting Screw	1
18	192139	KK-5059	Bushing, Spring, Pad & Knob Kit	1
●19	—	—	Air Valve Spring	1
●20	—	—	Air Valve	1
21	—	—	Air Valve Body	1
●22	—	—	U Cup Seal	1
●23	—	—	Washer	1
●24	—	—	Snap Ring	1
25	190780	JGS-449-1	Air Valve Assembly	1
26	190287	P-MB-51	Air Inlet Nipple 1/4" NPS(M)	1
27	—	—	Trigger Stud Screw	1
28	—	—	Trigger Stud	1
29	190889	JGS-478	Stud & Screw Kit (3 Studs & 5 Screws)	1
30	—	—	Trigger	1
31	191943	JGS-477-1	Trigger, Stud & Screw Kit	1
●32	—	—	Fluid Inlet Gasket (PTFE)	1
33	—	—	Locknut	1
34	—	—	Fluid Inlet Adapter	1
35	190888	JGA-4042	Fluid Inlet, Gasket & Nut Kit	1
●36	—	—	Retaining Clip	1
●37	—	—	Seal	1
●38	—	—	Pin	1
39	192229	GTI-428-K5	Clip, Seal & Pin Kit (5 Each)	1
40	190828	JGA-132	Plug	1
41	192228	GTI-415	Air Adjusting Valve (Optional)	1