

LockForce 2025 Tool

Huck has built a reputation for ergonomically engineered tools that add to the productivity of any operation. That reputation is only enhanced by the introduction of the Huck Model 2025 Pneudraulic Installation Tool. This high performance, ergonomic tool is designed for use with blind rivets and small two-piece fasteners, for both high speed production (to 35 fasteners/minute) and repair applications. Lightweight, reliable and easy to use, these tools deliver a level of performance and ergonomics never before possible in a low cost pneudraulic tool.



**Huck
Fasteners**

From Cordant Technologies

Choice of Models

The 2025 is available in four versions for the best match of tool to application:

- The standard 2025 features a pintail deflector configuration
- The 2025L includes an extended piston for installing two-piece fasteners with a single stroke
- The 2025V includes a vacuum assist pintail collection bottle
- The 2025LV combines both an extended piston and vacuum assist pintail collection bottle

High Performance Features

The 2025 tools feature reliability, safety, and long, trouble-free life, while providing for an installation rate of 35 fasteners per minute. And operator productivity is reduced by the tool's ergonomic design, light weight and reduced noise levels (75 dBA). Operator productivity remains as high at the end of the shift as it was at the beginning. And like all Huck pneumatic tools, the 2025 series delivers uniform strength and clamp force, with the highest power-to-weight ratios in its class.

Specifications

Weight	5.75 lbs.
Required Air Pressure	90-110 psi
Air Consumption	1.4 CFM based on 30 cycle per minute
Hydraulic Fluid	Automatic Transmission Fluid DEXTRON II® or equivalent
Stroke	0.675 in.

Key 2025 features include:

- In-line piston for one-stroke installation
- Front wiper combined with POLY-SEAL for long tool life
- Less than 5.8 lbs. for ease of use
- Ergonomically designed hand grip
- 360° swivel air inlet connection, reducing hose wear
- Plated piston rods for long life
- Noise level 75 dBA @90 psi

Proven Reliability

Ruggedness and dependability are standard features of every Huck tool. These workhorse tools include such life-extending features as chrome-plated piston rods, a reduced number of moving parts, and durable all-steel construction. Trust Huck for the most efficient, versatile, and reliable tooling available - true Tools of Productivity.

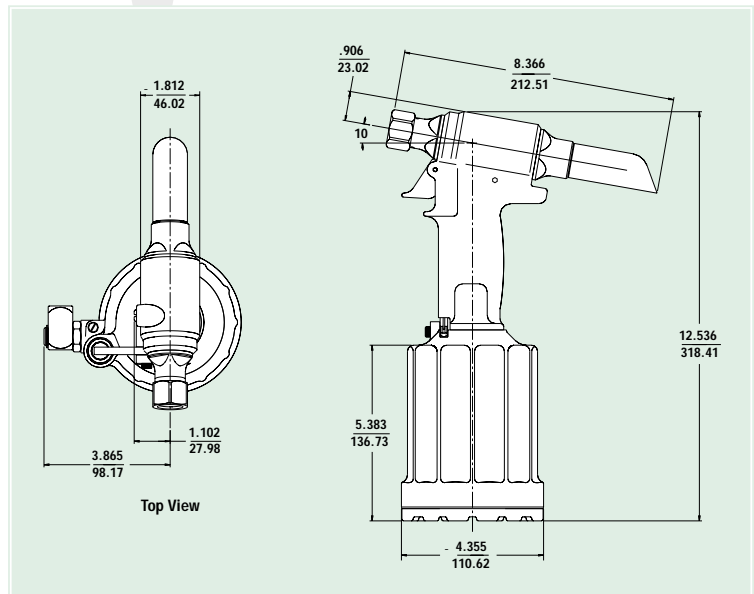

**Huck
Fasteners**

From Cordant Technologies

HUCK International, Inc.
1 Corporate Drive, Kingston, NY 12401
800/278-4825 • 914/334-7333 Fax
www.huck.com