

15.0 Chisel specifications

JET® JBM-5 Benchtop Mortiser (708580) Specifications in conjunction with our Premium Chisel and Bit Sets

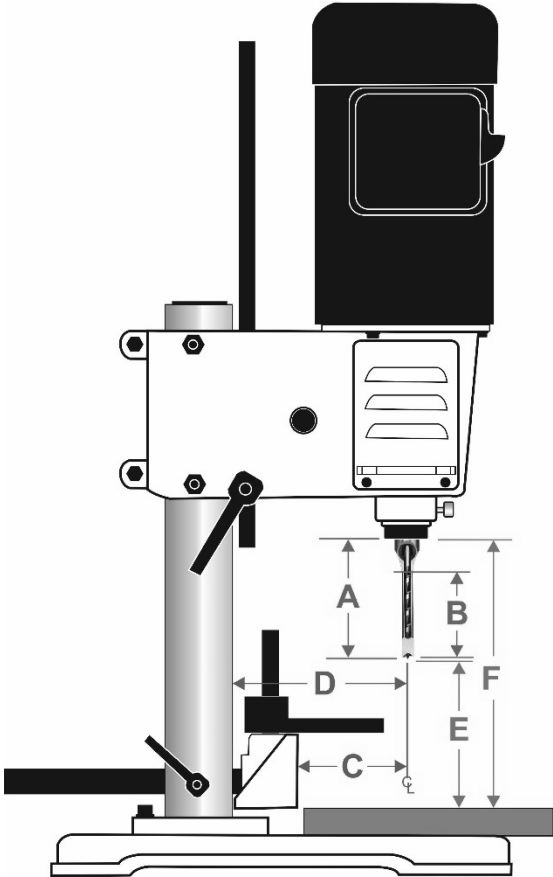

JET JBM-5 Mortiser with Premium Chisels		1791091	1791092	1791093	1791094
		1/4" chisel ¹	5/16" chisel	3/8" chisel	1/2" chisel
A	Total Chisel Length (installed)	3-21/32"	3-7/8	3-7/8"	3-7/8"
B	Useful Chisel Plunge	1-13/16"	2-1/8"	2-3/4"	3-5/32"
C	Maximum Chisel Centerline to Fence	3-3/16"	3-3/16"	3-3/16"	3-3/16"
D	Maximum Chisel Centerline to Column	5"	5"	5"	5"
E	Maximum Working Clearance ^{2,3}	4-1/2"	4-5/16"	4-5/16"	4-5/16"
F	Maximum Total Clearance ²	8-1/4"	8-1/4"	8-1/4"	8-1/4"
	Bushing size used (inside diameter)	3/4"	3/4"	3/4"	3/4"

¹ Chisel size refers to dimension of square hole produced by the chisel.

² Measured with provided wood table installed; add 3/4" to each figure if wood table is removed.

³ Bit protrusion of 1/16" is assumed.