

## 39000 "NO SLIP" PULLEY PULLER/INSTALLER

Removes and Installs Pressed on Power Steering, Alternator and Air Pump Pulleys.

Makes removing pressed on pulleys an easy job. The unique puller body completely houses the pulley hub to prevent slipping on even the tightest pulleys. Fits most domestic models including GM 3.1 and Quad 4 engines. Works on traditional V shaped pulleys and serpentine belt system pulleys. Also works faster than other conventional pulley pullers. Patented design traps the pulley and provides a gripping handle. Tool comes with detailed instructions and a heavy-duty plastic storage case.

**39000 "No Slip" Pulley Puller/Installer.** Molded Case. Shipping wt. 2 lbs. 2 oz.

**38910 Short 3/8"x16 Install. Adapter**      **38920 Short 8mm Install. Adapter**

**38930 Med. 3/8"x16 Install. Adapter**      **38940 Short Pin**

**38950 Long Pin**      **38960 Long 3/8"x16 Install. Adapter**

**38990 Puller Screw**      **39010 Small Jaw**

**39020 Large Jaw**      **39030 Handle**

**39040 Washer**      **39050 Nut**

**39070 Pusher Shaft**      **40060 Bearing**



U.S. Pat No. 7,007,359

## 57340 STEERING WHEEL LOCK PLATE TOOL

Fits Domestic Lock Plates, Including Tilt & Telescoping.

Tool depresses lock plate for easy removal of lock ring. Allows access to steering column for repair work. Comes with standard and metric adapters, plus two puller frames. Fits most domestic lock plates, including tilt and telescoping columns. Works on vehicles with air bags.

**57340 Steering Wheel Lock Plate Tool.** Skin-packed. Shipping wt. 1 lb. 8 oz.

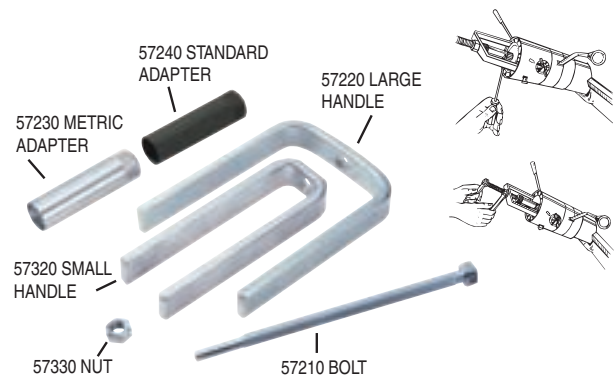

## 45000 STEERING WHEEL PULLER

Universal Puller for Most Makes & Models.

Screw pad protects end of steering shaft. Heavy duty for long wear.

**45000 Steering Wheel Puller.** Clam Shell. Shipping wt. 1 lb. 10 oz.

**45050 Screw Pad**

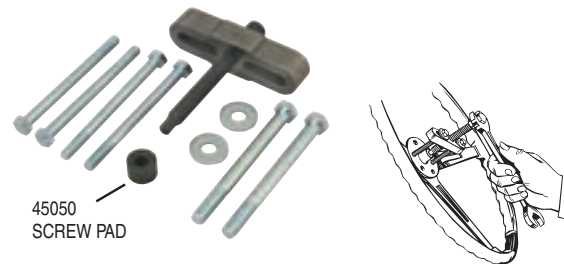

## 19940 PIVOT PIN REMOVER

Removes the pivot pin on GM, Ford and Chrysler tilt and telescoping Saginaw steering columns. Includes an extra screw.

**19940 Pivot Pin Remover.** Skin-packed. Shipping wt. 2 oz.

**19970 Cap Screw**

