

45900 HOOD PROP

Works on All Makes of Cars and Trucks.

The three-piece, telescoping design allows the mechanic to hold the hood in the desired position. The tool telescopes from 18-1/2" to 46-3/4". Can be used from the side of car for better access to the engine compartment. Also great for body or repair work on door, trunk lids, or hatchbacks.

45900 Hood Prop. Skin-packed. Shipping wt. 2 lbs. 3 oz.

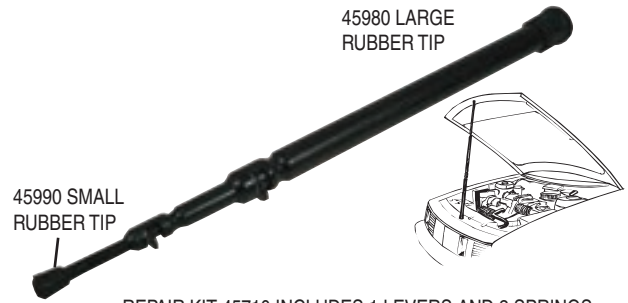

REPAIR KIT 45710 INCLUDES 1 LEVERS AND 2 SPRINGS

46170 HOOD PROP WITH SUPPORT

Includes a Support to Help Prevent Slipping.

The tool includes our standard 45900 Hood Prop plus a support to help prevent the bottom of the tool from slipping. The tool with the support telescopes from 20" to 48-1/4". Place the support over a hood adjuster. Then set the hood prop base into the holding support.

46170 Hood Prop. Skin-packed. Shipping wt. 2 lbs. 4 oz.

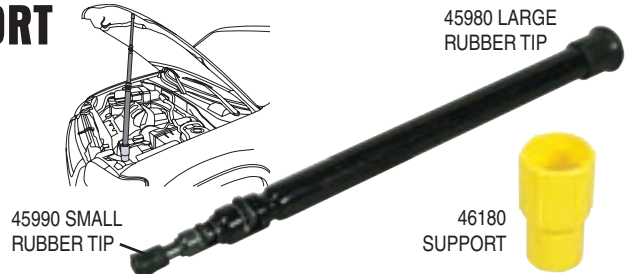

U.S. Pat No. 7,410,142

59800 SERPENTINE BELT TOOL

Releases Tension on Serpentine Belts With a Spring Loaded Idler Pulley.

This tool is used to remove and install belts on serpentine belt systems using the spring loaded idler pulley. For applications with limited access, 13mm and 16mm sockets are built into the handle. This tool covers most domestic and some import applications. Comes with extension for hard-to-reach idler pulleys. Eight low profile sockets and extension help to fit into tight spots. Includes 19mm socket for Honda and Toyota applications.

59800 Serpentine Belt Tool. Skin-packed. Shipping wt. 2 lbs. 4 oz.

57520 Socket Set.



Part #	Description
57390	14mm Socket
57440	15mm Socket
57450	18mm Socket
57500	13mm Socket
57530	3/8" Square Drive
57560	1/2" Square Drive
57580	16mm Socket
59100	Extension
59140	19mm Socket
59780	Handle Assembly

59000 RATCHETING SERPENTINE BELT TOOL

Releases Tension on Serpentine Belts With a Spring Loaded Idler Pulley.

Ratcheting head with freewheel position allows maximum leverage. Set ratcheting head to the middle or neutral/ freewheel position and once maximum travel point is reached simply click lever into place to lock the ratchet mechanism. Comes with extension for hard-to-reach idler pulleys. This tool will work where conventional ratchets or breaker bars won't fit due to limited access. Includes 19mm socket for Honda and Toyota applications.

59000 Ratcheting Serpentine Belt Tool. Skin-packed. Shipping wt. 2 lbs. 10 oz.

57520 Socket Set.



Part #	Description
57390	14mm Socket
57440	15mm Socket
57450	18mm Socket
57500	13mm Socket
57530	3/8" Square Drive
57560	1/2" Square Drive
57580	16mm Socket
59100	Extension
59140	19mm Socket
59190	Handle Assembly

11750 CLUTCH COUPLING REMOVER FOR FORD

Disconnects Ford Hydraulic Clutch Lines.

Easily disengages the hydraulic clutch line from the clutch slave cylinder on some Ford manual transmissions. Tool prongs fit around clutch line above nylon sleeve.

11750 Clutch Coupling Remover for Ford. Skin-packed. Shipping wt. 2 oz.

