

INSTRUCTION MANUAL  
MANUEL D'INSTRUCTION  
MANUAL DE INSTRUCCIONES

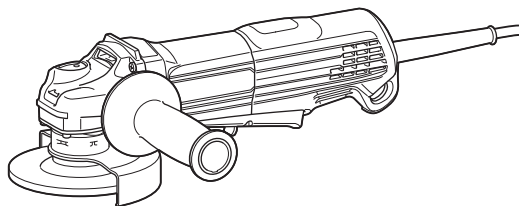

# Angle Grinder Meuleuse d'Angle Esmeriladora Angular

**GA4553R**  
**GA5053R**



DOUBLE INSULATION  
DOUBLE ISOLATION  
DOBLE AISLAMIENTO



Read before use.  
À lire avant l'utilisation.  
Lea antes de usar.

## SPECIFICATIONS

Model:	GA4553R	GA5053R
Wheel diameter	115 mm (4-1/2")	125 mm (5")
Max. wheel thickness	7.2 mm (9/32")	
Spindle thread	5/8"	
Rated speed (n)	11,000 /min	
Overall length	325 mm (12-3/4")	
Net weight	2.5 - 2.7 kg (5.5 - 6.0 lbs)	
Safety class	□/II	

- Due to our continuing program of research and development, the specifications herein are subject to change without notice.
- Specifications may differ from country to country.
- The weight may differ depending on the attachment(s). The lightest and heaviest combination, according to EPTA-Procedure 01/2014, are shown in the table.

### Power supply

The tool should be connected only to a power supply of the same voltage as indicated on the nameplate, and can only be operated on single-phase AC supply. They are double-insulated and can, therefore, also be used from sockets without earth wire.

## SAFETY WARNINGS

### General power tool safety warnings

**⚠ WARNING:** Read all safety warnings, instructions, illustrations and specifications provided with this power tool. Failure to follow all instructions listed below may result in electric shock, fire and/or serious injury.

### Save all warnings and instructions for future reference.

The term "power tool" in the warnings refers to your mains-operated (corded) power tool or BATTERY-operated (cordless) power tool.

#### Work area safety

1. **Keep work area clean and well lit.** Cluttered or dark areas invite accidents.
2. **Do not operate power tools in explosive atmospheres, such as in the presence of flammable liquids, gases or dust.** Power tools create sparks which may ignite the dust or fumes.
3. **Keep children and bystanders away while operating a power tool.** Distractions can cause you to lose control.

#### Electrical Safety

1. **Power tool plugs must match the outlet. Never modify the plug in any way. Do not use any adapter plugs with earthed (grounded) power tools.** Unmodified plugs and matching outlets will reduce risk of electric shock.

2. **Avoid body contact with earthed or grounded surfaces, such as pipes, radiators, ranges and refrigerators.** There is an increased risk of electric shock if your body is earthed or grounded.
3. **Do not expose power tools to rain or wet conditions.** Water entering a power tool will increase the risk of electric shock.
4. **Do not abuse the cord. Never use the cord for carrying, pulling or unplugging the power tool. Keep cord away from heat, oil, sharp edges or moving parts.** Damaged or entangled cords increase the risk of electric shock.
5. **When operating a power tool outdoors, use an extension cord suitable for outdoor use.** Use of a cord suitable for outdoor use reduces the risk of electric shock.
6. **If operating a power tool in a damp location is unavoidable, use a Residual Current Device (RCD) protected supply.** Use of an RCD reduces the risk of electric shock.
7. **Power tools can produce electromagnetic fields (EMF) that are not harmful to the user.** However, users of pacemakers and other similar medical devices should contact the maker of their device and/or doctor for advice before operating this power tool.
8. **Do not touch the power plug with wet hands.**
9. **If the cord is damaged, have it replaced by the manufacturer or his agent in order to avoid a safety hazard.**

#### Personal Safety

1. **Stay alert, watch what you are doing and use common sense when operating a power tool. Do not use a power tool while you are tired or under the influence of drugs, alcohol or medication.** A moment of inattention while operating power tools may result in serious personal injury.
2. **Use personal protective equipment. Always wear eye protection.** Protective equipment such as dust mask, non-skid safety shoes, hard hat, or hearing protection used for appropriate conditions will reduce personal injuries.

3. **Prevent unintentional starting. Ensure the switch is in the off-position before connecting to power source and/or BATTERY pack, picking up or carrying the tool.** Carrying power tools with your finger on the switch or energising power tools that have the switch on invites accidents.
4. **Remove any adjusting key or wrench before turning the power tool on.** A wrench or a key left attached to a rotating part of the power tool may result in personal injury.
5. **Do not overreach. Keep proper footing and balance at all times.** This enables better control of the power tool in unexpected situations.
6. **Dress properly. Do not wear loose clothing or jewellery. Keep your hair, clothing and gloves away from moving parts.** Loose clothes, jewellery or long hair can be caught in moving parts.
7. **If devices are provided for the connection of dust extraction and collection facilities, ensure these are connected and properly used.** Use of dust collection can reduce dust-related hazards.
8. **Do not let familiarity gained from frequent use of tools allow you to become complacent and ignore tool safety principles.** A careless action can cause severe injury within a fraction of a second.
9. **Always wear protective goggles to protect your eyes from injury when using power tools. The goggles must comply with ANSI Z87.1 in the USA. It is an employer's responsibility to enforce the use of appropriate safety protective equipment by the tool operators and by other persons in the immediate working area.**
5. **Maintain power tools and accessories. Check for misalignment or binding of moving parts, breakage of parts and any other condition that may affect the power tool's operation. If damaged, have the power tool repaired before use.** Many accidents are caused by poorly maintained power tools.
6. **Keep cutting tools sharp and clean.** Properly maintained cutting tools with sharp cutting edges are less likely to bind and are easier to control.
7. **Use the power tool, accessories and tool bits etc. in accordance with these instructions, taking into account the working conditions and the work to be performed.** Use of the power tool for operations different from those intended could result in a hazardous situation.
8. **Keep handles and grasping surfaces dry, clean and free from oil and grease.** Slippery handles and grasping surfaces do not allow for safe handling and control of the tool in unexpected situations.
9. **When using the tool, do not wear cloth work gloves which may be entangled.** The entanglement of cloth work gloves in the moving parts may result in personal injury.

#### Service

1. **Have your power tool serviced by a qualified repair person using only identical replacement parts.** This will ensure that the safety of the power tool is maintained.
2. **Follow instruction for lubricating and changing accessories.**

To reduce the risk of electric shock, this equipment has a polarized plug (one blade is wider than the other). This plug will fit in a polarized outlet only one way. If the plug does not fit fully in the outlet, reverse the plug. If it still does not fit, contact a qualified electrician to install the proper outlet. Do not change the plug in any way.

**VOLTAGE WARNING:** Before connecting the tool to a power source (receptacle, outlet, etc.) be sure the voltage supplied is the same as that specified on the nameplate of the tool. A power source with voltage greater than that specified for the tool can result in SERIOUS INJURY to the user- as well as damage to the tool. If in doubt, DO NOT PLUG IN THE TOOL. Using a power source with voltage less than the nameplate rating is harmful to the motor.

**USE PROPER EXTENSION CORD.** Make sure your extension cord is in good condition. When using an extension cord, be sure to use one heavy enough to carry the current your product will draw. An undersized cord will cause a drop in line voltage resulting in loss of power and overheating. Table 1 shows the correct size to use depending on cord length and nameplate ampere rating. If in doubt, use the next heavier gage. The smaller the gage number, the heavier the cord.

#### Power tool use and care

1. **Do not force the power tool. Use the correct power tool for your application.** The correct power tool will do the job better and safer at the rate for which it was designed.
2. **Do not use the power tool if the switch does not turn it on and off.** Any power tool that cannot be controlled with the switch is dangerous and must be repaired.
3. **Disconnect the plug from the power source and/ or remove the BATTERY pack, if detachable, from the power tool before making any adjustments, changing accessories, or storing power tools.** Such preventive safety measures reduce the risk of starting the power tool accidentally.
4. **Store idle power tools out of the reach of children and do not allow persons unfamiliar with the power tool or these instructions to operate the power tool.** Power tools are dangerous in the hands of untrained users.

**Table 1: Minimum gage for cord**

Ampere Rating		Volts	Total length of cord in feet			
			25 ft.	50 ft.	100 ft.	150 ft.
		120V	25 ft.	50 ft.	100 ft.	150 ft.
		220V - 240V	50 ft.	100 ft.	200 ft.	300 ft.
More Than	Not More Than	AWG				
0 A	6 A	-	18	16	16	14
6 A	10 A		18	16	14	12
10 A	12 A		16	16	14	12
12 A	16 A		14	12	Not Recommended	

## Grinder safety warnings

### Safety Warnings Common for Grinding, Wire Brushing Operations:

1. **This power tool is intended to function as a grinder or wire brush. Read all safety warnings, instructions, illustrations and specifications provided with this power tool.** Failure to follow all instructions listed below may result in electric shock, fire and/or serious injury.
2. **Operations such as polishing, sanding and cutting-off are not recommended to be performed with this power tool.** Operations for which the power tool was not designed may create a hazard and cause personal injury.
3. **Do not use accessories which are not specifically designed and recommended by the tool manufacturer.** Just because the accessory can be attached to your power tool, it does not assure safe operation.
4. **The rated speed of the accessory must be at least equal to the maximum speed marked on the power tool.** Accessories running faster than their rated speed can break and fly apart.
5. **The outside diameter and the thickness of your accessory must be within the capacity rating of your power tool.** Incorrectly sized accessories cannot be adequately guarded or controlled.
6. **Threaded mounting of accessories must match the grinder spindle thread. For accessories mounted by flanges, the arbour hole of the accessory must fit the locating diameter of the flange.** Accessories that do not match the mounting hardware of the power tool will run out of balance, vibrate excessively and may cause loss of control.
7. **Do not use a damaged accessory. Before each use inspect the accessory such as wire brush for loose or cracked wires. If power tool or accessory is dropped, inspect for damage or install an undamaged accessory. After inspecting and installing an accessory, position yourself and bystanders away from the plane of the rotating accessory and run the power tool at maximum no-load speed for one minute.** Damaged accessories will normally break apart during this test time.
8. **Wear personal protective equipment. Depending on application, use face shield, safety goggles or safety glasses. As appropriate, wear dust mask, hearing protectors, gloves and workshop apron capable of stopping small abrasive or workpiece fragments.** The eye protection must be capable of stopping flying debris generated by various operations. The dust mask or respirator must be capable of filtering particles generated by your operation. Prolonged exposure to high intensity noise may cause hearing loss.
9. **Keep bystanders a safe distance away from work area. Anyone entering the work area must wear personal protective equipment.** Fragments of workpiece or of a broken accessory may fly away and cause injury beyond immediate area of operation.

10. **Hold the power tool by insulated gripping surfaces only, when performing an operation where the cutting accessory may contact hidden wiring or its own cord.** Cutting accessory contacting a "live" wire may make exposed metal parts of the power tool "live" and could give the operator an electric shock.
11. **Position the cord clear of the spinning accessory.** If you lose control, the cord may be cut or snagged and your hand or arm may be pulled into the spinning accessory.
12. **Never lay the power tool down until the accessory has come to a complete stop.** The spinning accessory may grab the surface and pull the power tool out of your control.
13. **Do not run the power tool while carrying it at your side.** Accidental contact with the spinning accessory could snag your clothing, pulling the accessory into your body.
14. **Regularly clean the power tool's air vents.** The motor's fan will draw the dust inside the housing and excessive accumulation of powdered metal may cause electrical hazards.
15. **Do not operate the power tool near flammable materials.** Sparks could ignite these materials.
16. **Do not use accessories that require liquid coolants.** Using water or other liquid coolants may result in electrocution or shock.

### Kickback and Related Warnings

Kickback is a sudden reaction to a pinched or snagged rotating wheel, backing pad, brush or any other accessory. Pinching or snagging causes rapid stalling of the rotating accessory which in turn causes the uncontrolled power tool to be forced in the direction opposite of the accessory's rotation at the point of the binding. For example, if an abrasive wheel is snagged or pinched by the workpiece, the edge of the wheel that is entering into the pinch point can dig into the surface of the material causing the wheel to climb out or kick out. The wheel may either jump toward or away from the operator, depending on direction of the wheel's movement at the point of pinching. Abrasive wheels may also break under these conditions.

Kickback is the result of power tool misuse and/or incorrect operating procedures or conditions and can be avoided by taking proper precautions as given below.

1. **Maintain a firm grip on the power tool and position your body and arm to allow you to resist kickback forces. Always use auxiliary handle, if provided, for maximum control over kickback or torque reaction during start-up.** The operator can control torque reactions or kickback forces, if proper precautions are taken.
2. **Never place your hand near the rotating accessory.** Accessory may kickback over your hand.
3. **Do not position your body in the area where power tool will move if kickback occurs.** Kickback will propel the tool in direction opposite to the wheel's movement at the point of snagging.
4. **Use special care when working corners, sharp edges etc. Avoid bouncing and snagging the accessory.** Corners, sharp edges or bouncing have a tendency to snag the rotating accessory and cause loss of control or kickback.

5. **Do not attach a saw chain woodcarving blade or toothed saw blade.** Such blades create frequent kickback and loss of control.

#### Safety Warnings Specific for Grinding Operations:

1. **Use only wheel types that are recommended for your power tool and the specific guard designed for the selected wheel.** Wheels for which the power tool was not designed cannot be adequately guarded and are unsafe.
2. **The grinding surface of centre depressed wheels must be mounted below the plane of the guard lip.** An improperly mounted wheel that projects through the plane of the guard lip cannot be adequately protected.
3. **The guard must be securely attached to the power tool and positioned for maximum safety, so the least amount of wheel is exposed towards the operator.** The guard helps to protect the operator from broken wheel fragments, accidental contact with wheel and sparks that could ignite clothing.
4. **Wheels must be used only for recommended applications.**
5. **Always use undamaged wheel flanges that are of correct size and shape for your selected wheel.** Proper wheel flanges support the wheel thus reducing the possibility of wheel breakage.
6. **Do not use worn down wheels from larger power tools.** Wheel intended for larger power tool is not suitable for the higher speed of a smaller tool and may burst.

#### Safety Warnings Specific for Wire Brushing Operations:

1. **Be aware that wire bristles are thrown by the brush even during ordinary operation. Do not overstress the wires by applying excessive load to the brush.** The wire bristles can easily penetrate light clothing and/or skin.
2. **If the use of a guard is recommended for wire brushing, do not allow any interference of the wire wheel or brush with the guard.** Wire wheel or brush may expand in diameter due to work load and centrifugal forces.

#### Additional Safety Warnings:

1. **When using depressed centre grinding wheels, be sure to use only fiberglass-reinforced wheels.**
2. **NEVER USE Stone Cup type wheels with this grinder.** This grinder is not designed for these types of wheels and the use of such a product may result in serious personal injury.
3. **Be careful not to damage the spindle, the flange (especially the installing surface) or the lock nut.** Damage to these parts could result in wheel breakage.
4. **Make sure the wheel is not contacting the workpiece before the switch is turned on.**
5. **Before using the tool on an actual workpiece, let it run for a while. Watch for vibration or wobbling that could indicate poor installation or a poorly balanced wheel.**
6. **Use the specified surface of the wheel to perform the grinding.**

7. **Do not leave the tool running. Operate the tool only when hand-held.**
8. **Do not touch the workpiece immediately after operation; it may be extremely hot and could burn your skin.**
9. **Observe the instructions of the manufacturer for correct mounting and use of wheels. Handle and store wheels with care.**
10. **Do not use separate reducing bushings or adaptors to adapt large hole abrasive wheels.**
11. **Use only flanges specified for this tool.**
12. **For tools intended to be fitted with threaded hole wheel, ensure that the thread in the wheel is long enough to accept the spindle length.**
13. **Check that the workpiece is properly supported.**
14. **Pay attention that the wheel continues to rotate after the tool is switched off.**
15. **If working place is extremely hot and humid, or badly polluted by conductive dust, use a short-circuit breaker (30 mA) to assure operator safety.**
16. **Do not use the tool on any materials containing asbestos.**
17. **Do not use cloth work gloves during operation.** Fibers from cloth gloves may enter the tool, which causes tool breakage.

## SAVE THESE INSTRUCTIONS.

**⚠WARNING:** DO NOT let comfort or familiarity with product (gained from repeated use) replace strict adherence to safety rules for the subject product. MISUSE or failure to follow the safety rules stated in this instruction manual may cause serious personal injury.

### Symbols

The followings show the symbols used for tool.

v	volts
A	amperes
Hz	hertz
~	alternating current
n	rated speed
	Class II Construction
... /min r /min	revolutions or reciprocation per minute
∅	diameter

## FUNCTIONAL DESCRIPTION

**CAUTION:** Always be sure that the tool is switched off and unplugged before adjusting or checking function on the tool.

### Shaft lock

Press the shaft lock to prevent spindle rotation when installing or removing accessories.

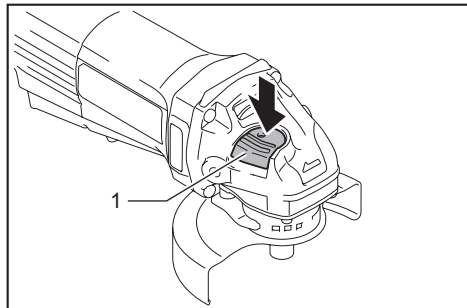

► 1. Shaft lock

**NOTICE:** Never actuate the shaft lock when the spindle is moving. The tool may be damaged.

### Switch action

**CAUTION:** Before plugging in the tool, always check to see that the switch trigger actuates properly and returns to the "OFF" position when released.

**CAUTION:** Do not pull the switch lever forcibly without pressing the lock-off button. The switch may break.

To prevent the switch lever from accidentally pulled, a lock-off lever is provided. To start the tool, pull the lock-off lever toward the operator, and then pull the switch lever. Release the switch lever to stop.

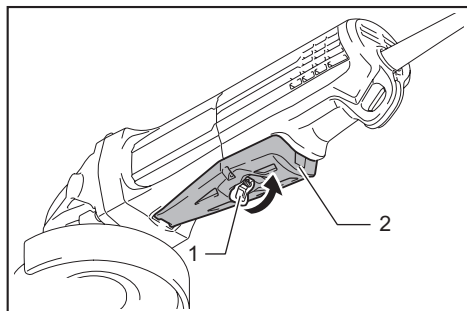

► 1. Lock-off lever 2. Switch lever

### Unintentional restart proof

The tool does not start while pulling the switch lever even when the tool is plugged. To start the tool, first release the switch lever. Then pull the lock-off lever, and pull the switch lever.

**NOTE:** Wait more than one second before restarting the tool when unintentional restart proof functions.

### Soft start feature

Soft start feature reduces starting reaction.

## ASSEMBLY

**CAUTION:** Always be sure that the tool is switched off and unplugged before carrying out any work on the tool.

### Installing side grip (handle)

**CAUTION:** Always be sure that the side grip is installed securely before operation.

Screw the side grip securely on the position of the tool as shown in the figure.

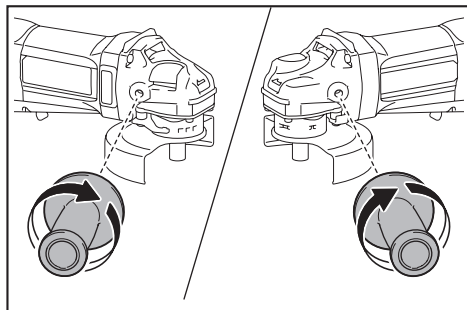

### Adjusting angle of wheel guard

**WARNING:** Make sure that the wheel guard is securely locked by the lock lever with one of the holes on the wheel guard.

The angle of the wheel guard can be adjusted by rotating the wheel guard with pushing it down while pushing the lock lever. Adjust the angle of the wheel guard according to the work so that the operator can be protected.

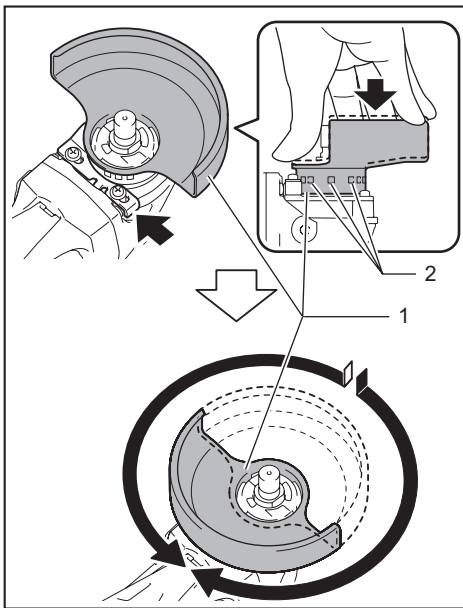

► 1. Wheel guard 2. Hole

## Installing or removing depressed center wheel or flap disc

### Optional accessory

**⚠ WARNING:** When using a depressed center wheel or flap disc, the wheel guard must be fitted on the tool so that the closed side of the guard always points toward the operator.

**⚠ CAUTION:** Make sure that the mounting part of the inner flange fits into the inner diameter of the depressed center wheel / flap disc perfectly. Mounting the inner flange on the wrong side may result in the dangerous vibration.

Mount the inner flange onto the spindle. Make sure to fit the dented part of the inner flange onto the straight part at the bottom of the spindle. Fit the depressed center wheel / flap disc on the inner flange and screw the lock nut onto the spindle.

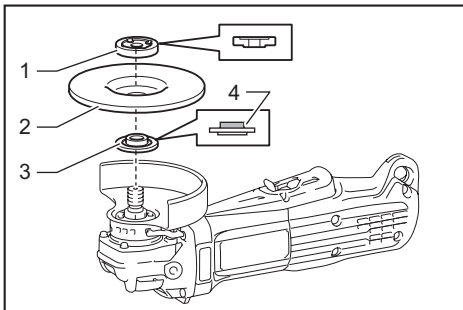

► 1. Lock nut 2. Depressed center wheel 3. Inner flange 4. Mounting part

To tighten the lock nut, press the shaft lock firmly so that the spindle cannot revolve, then use the lock nut wrench and securely tighten clockwise.

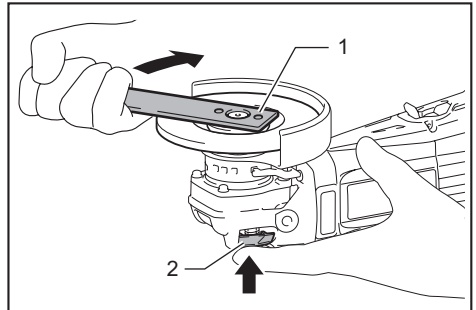

► 1. Lock nut wrench 2. Shaft lock

To remove the wheel, follow the installation procedure in reverse.

## Installing or removing flex wheel

### Optional accessory

**⚠ WARNING:** Always use supplied guard when flex wheel is on tool. Wheel can shatter during use and guard helps to reduce chances of personal injury.

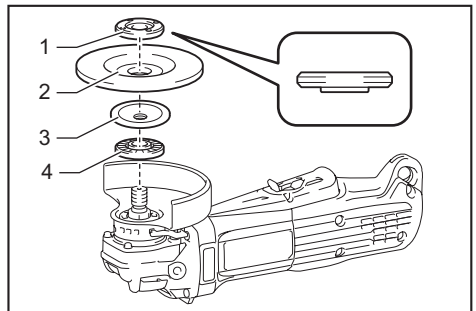

► 1. Lock nut 2. Flex wheel 3. Back up pad 4. Inner flange

Follow instructions for depressed center wheel but also use back up pad over wheel. See order of assembly on accessories page in this manual.



## OPERATION

**⚠WARNING:** It should never be necessary to force the tool. The weight of the tool applies adequate pressure. Forcing and excessive pressure could cause dangerous wheel breakage.

**⚠WARNING:** ALWAYS replace wheel if tool is dropped while grinding.

**⚠WARNING:** NEVER bang or hit grinding disc or wheel onto work.

**⚠WARNING:** Avoid bouncing and snagging the wheel, especially when working corners, sharp edges etc. This can cause loss of control and kickback.

**⚠WARNING:** NEVER use tool with wood cutting blades and other saw blades. Such blades when used on a grinder frequently kick and cause loss of control leading to personal injury.

**⚠WARNING:** Continued use of a worn-out wheel may result in wheel explosion and serious personal injury.

**⚠CAUTION:** Never switch on the tool when it is in contact with the workpiece, it may cause an injury to operator.

**⚠CAUTION:** Always wear safety goggles or a face shield during operation.

**⚠CAUTION:** After operation, always switch off the tool and wait until the wheel has come to a complete stop before putting the tool down.

**⚠CAUTION:** ALWAYS hold the tool firmly with one hand on housing and the other on the side grip (handle).

## Operation with wheel/disc

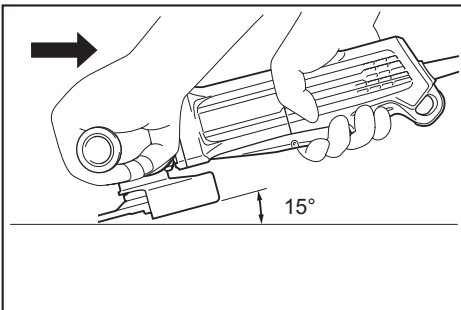

Turn the tool on and then apply the wheel or disc to the workpiece.

In general, keep the edge of the wheel or disc at an angle of about 15° to the workpiece surface. During the break-in period with a new wheel, do not work the grinder in forward direction or it may cut into the workpiece. Once the edge of the wheel has been rounded off by use, the wheel may be worked in both forward and backward direction.

## Operation with wire wheel brush

### Optional accessory

**⚠CAUTION:** Check operation of wire wheel brush by running tool with no load, insuring that no one is in front of or in line with the wire wheel brush.

**⚠CAUTION:** Do not use wire wheel brush that is damaged, or which is out of balance. Use of damaged wire wheel brush could increase potential for injury from contact with broken wires.

**⚠CAUTION:** ALWAYS use guard with wire wheel brushes, assuring diameter of wheel fits inside guard. Wheel can shatter during use and guard helps to reduce chances of personal injury.

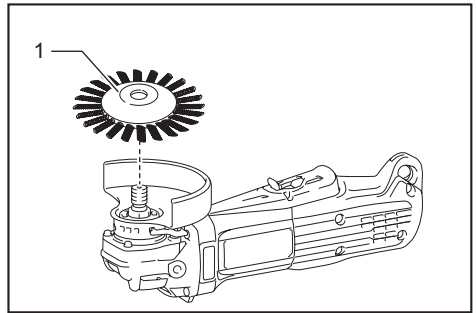

► 1. Wire wheel brush

Unplug tool and place it upside down allowing easy access to spindle.

Remove any accessories on spindle. Thread wire wheel brush onto spindle and tighten with the wrenches.

**NOTICE:** Avoid applying too much pressure which causes over bending of wires when using wire wheel brush. It may lead to premature breakage.

## Lanyard (tether strap) connection

**⚠Safety warnings specific for use at height**  
Read all safety warnings and instructions. Failure to follow the warnings and instructions may result in serious injury.

1. Always keep the tool tethered when working "at height". Maximum lanyard length is 2 m (6.5 ft).  
The maximum permissible fall height for lanyard (tether strap) must not exceed 2 m (6.5 ft).
2. Use only with lanyards appropriate for this tool type and rated for at least 4.0 kg (8.8 lbs).
3. Do not anchor the tool lanyard to anything on your body or on movable components. Anchor the tool lanyard to a rigid structure that can withstand the forces of a dropped tool.
4. Make sure the lanyard is properly secured at each end prior to use.



5. **Inspect the tool and lanyard before each use for damage and proper function (including fabric and stitching). Do not use if damaged or not functioning properly. The tool must be repaired especially when a crack or a red line appears around the hole for the lanyard.**
6. **Do not wrap lanyards around or allow them to come in contact with sharp or rough edges.**
7. **Fasten the other end of the lanyard outside the working area so that a falling tool is held securely.**
8. **Attach the lanyard so that the tool will move away from the operator if it falls.** Dropped tools will swing on the lanyard, which could cause injury or loss of balance.
9. **Do not use near moving parts or running machinery.** Failure to do so may result in a crush or entanglement hazard.
10. **Do not carry the tool by the attachment device or the lanyard.**
11. **Only transfer the tool between your hands while you are properly balanced.**
12. **Do not attach lanyards to the tool in a way that keeps guards, switches or lock-offs from operating properly.**
13. **Avoid getting tangled in the lanyard.**
14. **Keep lanyard away from the cutting area of the tool.**
15. **Use a locking carabiner (multi-action and screw gate type). Do not use single action spring clip carabiners.**
16. **In the event the tool is dropped, it must be tagged and removed from service, and should be inspected by a Makita Factory or Authorized Service Center.**
17. **Only attach the lanyard with a locking carabiner. Do not attach the lanyard by looping or knotting the lanyard. Do not use ropes or cords.**

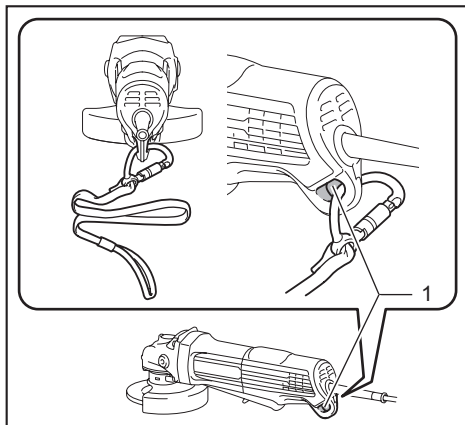

► 1. Hole for lanyard (tether strap)

## MAINTENANCE

**CAUTION:** Always be sure that the tool is switched off and unplugged before attempting to perform inspection or maintenance.

**NOTICE:** Never use gasoline, benzene, thinner, alcohol or the like. Discoloration, deformation or cracks may result.

To maintain product SAFETY and RELIABILITY, repairs, any other maintenance or adjustment should be performed by Makita Authorized or Factory Service Centers, always using Makita replacement parts.

### Air vent cleaning

The tool and its air vents have to be kept clean. Regularly clean the tool's air vents or whenever the vents start to become obstructed.

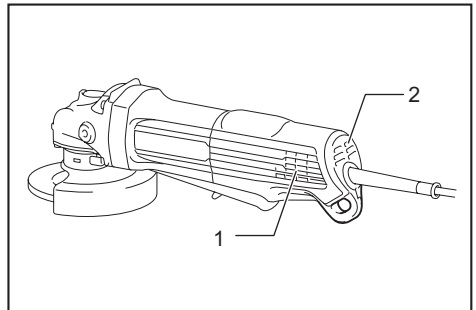

► 1. Exhaust vent 2. Inhalation vent

# OPTIONAL ACCESSORIES

**CAUTION:** These accessories or attachments are recommended for use with your Makita tool specified in this manual. The use of any other accessories or attachments might present a risk of injury to persons. Only use accessory or attachment for its stated purpose.

If you need any assistance for more details regarding these accessories, ask your local Makita Service Center.

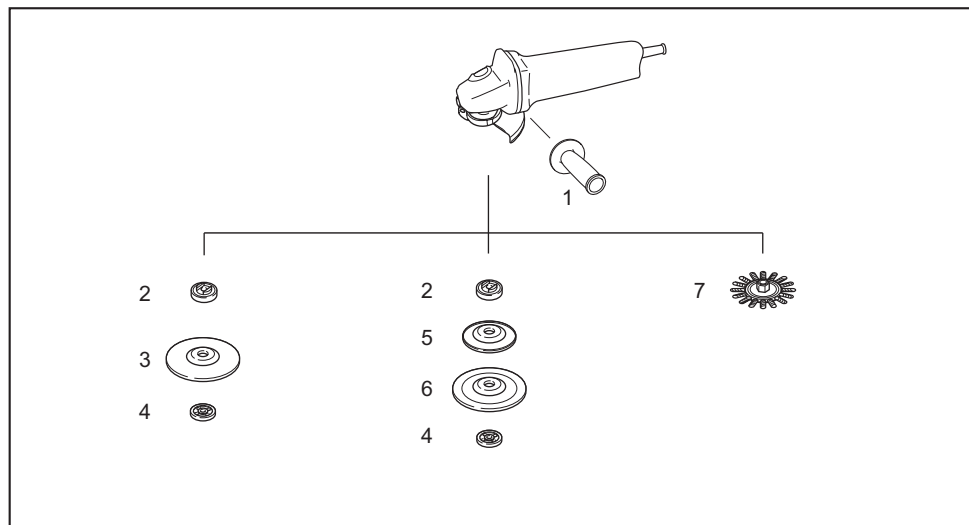

	115 mm (4-1/2") model	125 mm (5") model
1		Side grip
2		Inner flange
3		Depressed center wheel / Flap disc
4		Lock nut
5		Back up pad
6		Flex wheel
7		Wire wheel brush
-		Lock nut wrench
-		Dust cover attachment

**NOTE:** Some items in the list may be included in the tool package as standard accessories. They may differ from country to country.

## MAKITA LIMITED WARRANTY

Please refer to the annexed warranty sheet for the most current warranty terms applicable to this product. If annexed warranty sheet is not available, refer to the warranty details set forth at below website for your respective country.

United States of America: [www.makitatools.com](http://www.makitatools.com)

Canada: [www.makita.ca](http://www.makita.ca)

Other countries: [www.makita.com](http://www.makita.com)