

Air and water reels

Models 83753 and 83754

Series B

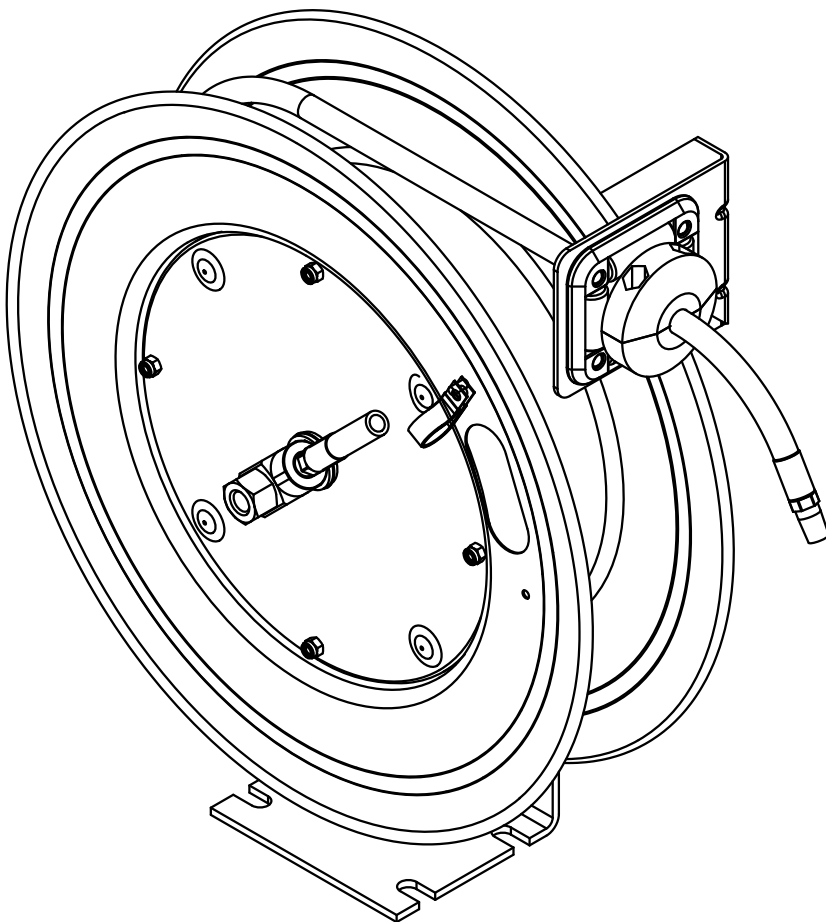

Date of issue	June 2014
Form number	404665A
Section	E35
Page	83A

⚠ DANGER

Read manual prior to installation or use of this product. Keep manual nearby for future reference. Failure to follow instructions and safety precautions may result in death or serious injury.

Dimensions

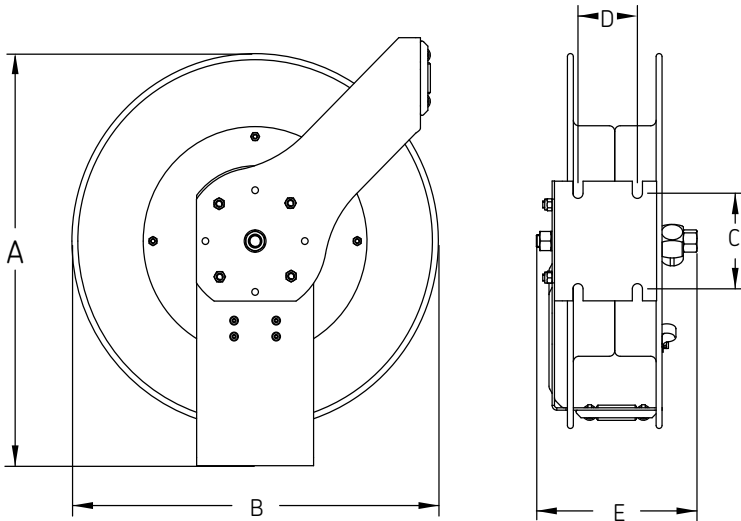

A	20.51 in. (520,9 mm)
B	19.30 in. (490,2 mm)
C	4.72 in. (119,8 mm)
D	2.99 in. (75,9 mm)
E	8.13 in. (206,5 mm)

Safety

Personal injury and/or equipment damage may result if proper safety precautions are not observed.

- Ensure that reel is properly installed before connecting input and output hoses.
- Bleed air/water pressure from system before servicing reel.
- Before connecting reel to supply line, ensure that pressure does not exceed maximum working pressure rating of reel.
- Remember, even low pressure is very dangerous and can cause personal injury or death.
- Be aware of machinery and personnel in work area.
- If a leak occurs in the hose or reel, remove system pressure immediately.
- A high tension spring assembly is contained within the reel. Exercise extreme caution.
- Pull hose from reel by grasping the hose itself, not the control valve.
- Ensure that reel, hose, and equipment being serviced are properly grounded.
- Use an ohmmeter to check ground continuity.
- If reel ceases to unwind or rewind, remove system pressure immediately. Do not pull or jerk on hose! Treat the hose reel as any other piece of machinery, observing all safety practices.

Specifications

Model	Maximum pressure psi (bar)	Delivery hose	Weight lbs. (kg)	Deliver hose outlet external threads	Connecting hose inlet external threads
83753	300 (21)	3/8 in. x 50 ft. (9,5 mm x 15,2 m)	34.5 (15,6)	1/4 in. NPTF	1/4 in. NPTF
83754	300 (21)	1/2 in. x 50 ft. (12,7 mm x 15,2 m)	37 (16,8)	1/2 in. NPTF	1/2 in. NPTF

¹⁾ Maximum operating temperature is 150 °F (66 °C).

Mount hose reel

Prior to mounting the hose reel, ensure that the supply line pressure does not exceed the maximum working pressure of the hose reel.

Do not exceed the maximum installation height of 16 ft. (4,8 m).

Unpack and inspect the reel for damage. Turn the spool by hand to check for a smooth operation.

Position the reel on the floor, wall or ceiling (not recommended for mobile applications).

Secure into place using four mounting bolts (not included).

Depending on where the reel is placed, it may be necessary to adjust the hose bumper and guide arm to use the hose properly.

Refer to **page 4** to adjust the hose bumper and reposition the guide arm.

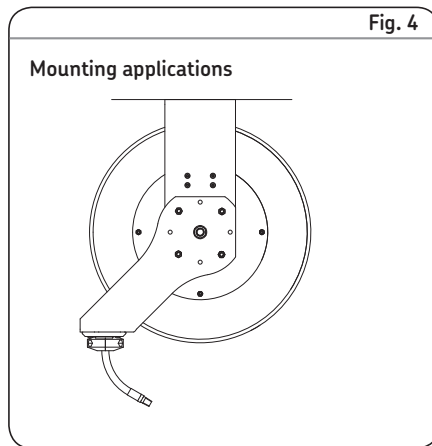
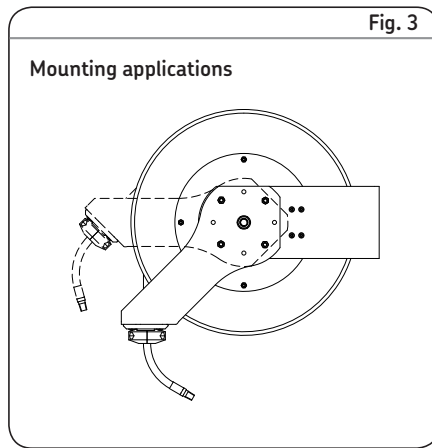
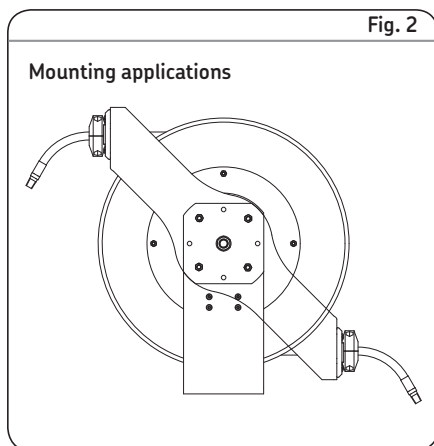
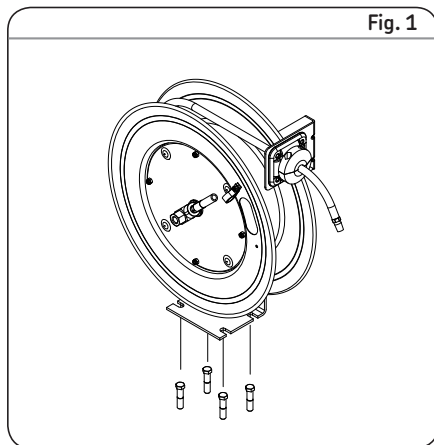

Notice
 Do not use rigid plumbing.
 Use flexible hose connection at input.
 Do not exceed recommended torque of 70 ft.lbf. (94 Nm).

Model 83753 requires 1/4 inch NPTF hose and Model 83754 requires 1/2 inch NPTF hose.
 Connecting hose not included.

Install connecting hose

- 1 Apply pipe thread sealant to threads on reels.
- 2 Thread connecting hose onto input → **figure 5**.
- 3 Tighten connecting hose fitting to a torque of 70 ft.lbf. (94 Nm).

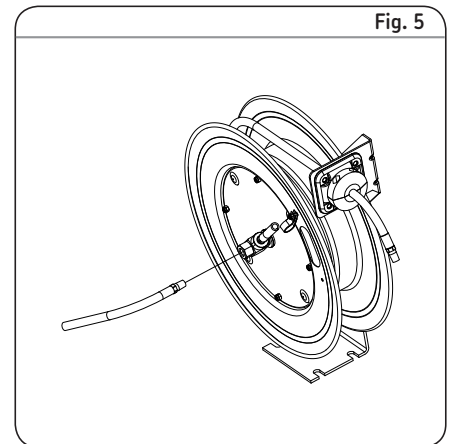

Adjust hose bumper

- 1 Pull out hose until latch pawl engages.
- 2 Loosen slotted screws shown in **fig. 6**.
- 3 Slide the bumper to desired position.
- 4 Tighten screws.
- 5 Pull hose to disengage latch pawl.
- 6 Allow hose to retract into reel.

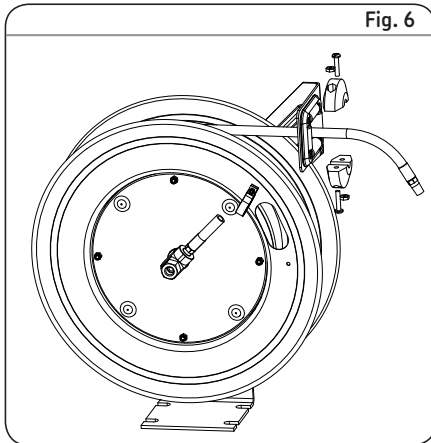

Remove guide arm

- 1 Pull out hose until latch pawl is engaged.
- 2 Remove slotted screws holding bumper in place (→ **fig. 6**).
- 3 Remove bumper.
- 4 Allow hose to retract into reel.
- 5 Remove 4 nuts holding guide arm on base (→ **fig. 7**).
- 6 Pull guide arm off of base.

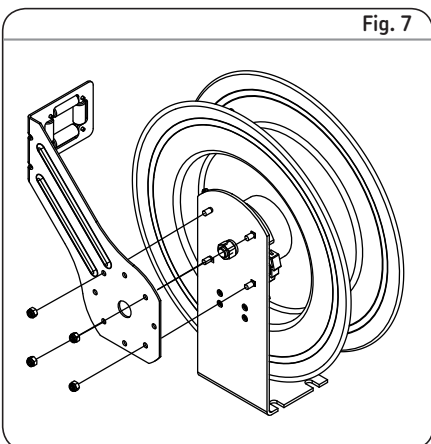

Position guide arm

- 1 Remove the guide arm.



Notice

Recommended guide arm positions for mounting applications are shown in **figures 2, 3, and 4 on page 3**.

- 2 Position guide arm in one of five positions shown in **fig. 8**.
- 3 Install and tighten four nuts on guide arm.
- 4 Tighten drive spring by turning spool two or three revolutions to engage latch pawl.
- 5 Pull hose through roller opening in guide arm.
- 6 Position bumper on hose.
- 7 Install and tighten screws in bumper. Refer to (→ **fig. 6**)

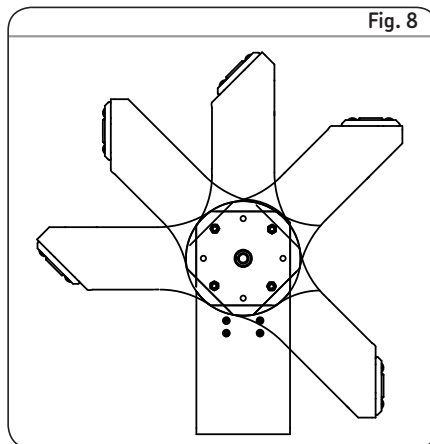

Replace latch pawl

- 1 Retract hose onto reel until bumper is against guide rollers and latch pawl is not engaged.
- 2 Remove nuts that fasten latch pawl assembly with socket-head cap screws.
- 3 Replace latch pawl assembly and tighten nuts.

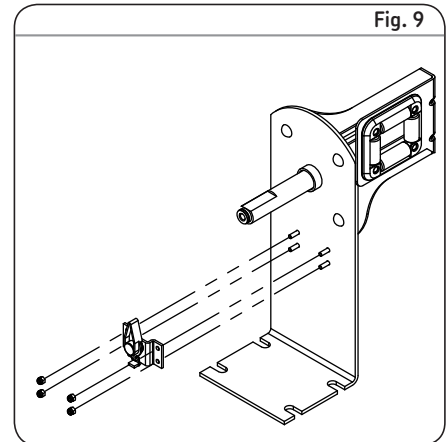

Replace hose

Remove the hose

- 1 Pull out the hose leaving 2 to 3 ft. (0,6 to 0,9 m) on the spool.
- 2 Engage the latch pawl.
- 3 Remove the screw nuts on the inside of the spool (→ **fig. 10**).
- 4 Remove the hose clamp.
- 5 Unthread the hose at the connection to the swivel.
- 6 Use a wrench on both fittings or the swivel may be damaged.
- 7 Remove the hose.

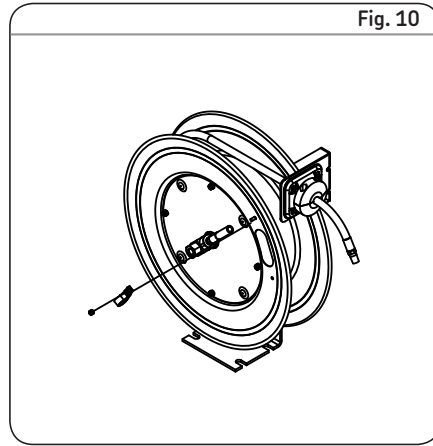

Install hose

- 1 Route the hose through the guide arm rollers and opening of the spool.
- 2 Apply thread tape or sealant to hose threads.
- 3 Screw hose fitting into threaded fitting on swivel.
- 4 Tighten connection with a wrench on both fittings.
- 5 Install the hose clamp (→ **fig. 10**).
- 6 Install hose bumper on working end of hose.
- 7 Disengage latch pawl and allow hose to retract.

Replace swivel

- 1 Remove the hose (→ **Replace hose**).
- 2 Remove swivel by unscrewing the threaded stem from the main shaft (→ **fig. 11**).
- 3 Replace swivel by screwing threaded stem of swivel into main shaft of reel.
- 4 Replace the hose.

! Notice

Do not use rigid plumbing. Use flexible hose connection at input. Do not exceed recommended torque of 70 ft.lbf. (94 Nm). Model 83753 swivel assembly has 1/4 inch NPTF internal threads and Model 83754 swivel assembly has 1/2 inch NPTF internal threads. Connecting hose not included.

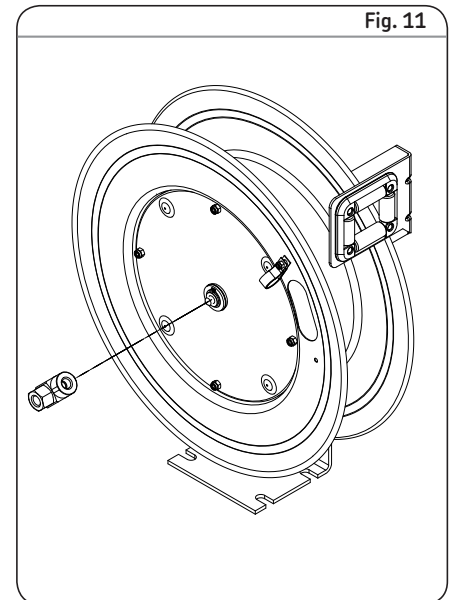

Service parts

Item Number	Description	Quantity	Model 83753 3/8 in. x 50 ft. (0,37 mm x 15,24 m)	Model 83754 1/2 in. x 50 ft (12,7 mm x 15,24 m)
1	Swivel assembly 1/4 inch NPT	1	279135	279136
15	Hose clamp	1	272167	272168
18	Ratchet and spacer assembly	1	279134	279134
28	Hose assembly	1	278749	278752
29	Bumper assembly	1	278665	278664
32	Latch pawl assembly	1	279133	279133

Parts

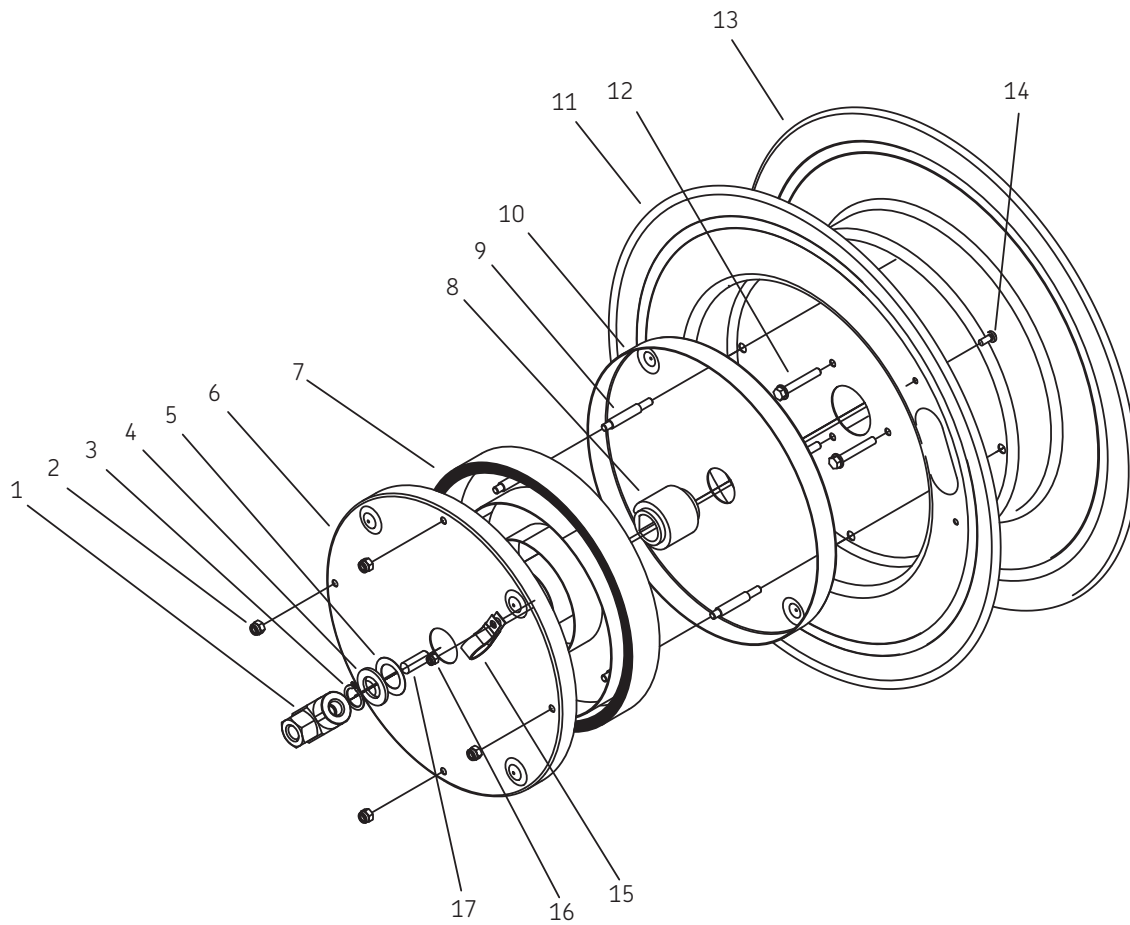

Illustrated parts breakdown

Item no.	Description	Quantity
1	Swivel assembly ¹⁾	1
2	Nut M6 ²⁾	4
3	Snap ring 19 ²⁾	1
4	Washer 18 ²⁾	1
5	Adjust washer ²⁾	3
6	Spring case cover ²⁾	1
7	Drive spring assembly ²⁾	1
8	Arbor ²⁾	1
9	Spring case stud ²⁾	4
10	Spring case ²⁾	1
11	Spring case sheave ²⁾	1
12	Hex washer screw ²⁾	3
13	Sheave flange ²⁾	1
14	Screw M5 x 12 ²⁾	1
15	Hose clamp ¹⁾	1
16	Nyloc nut M5 ²⁾	1
17	Screw M10 x 30 ²⁾	1

¹⁾ Refer to service parts table on page 5 for part numbers.

²⁾ Not available for order.

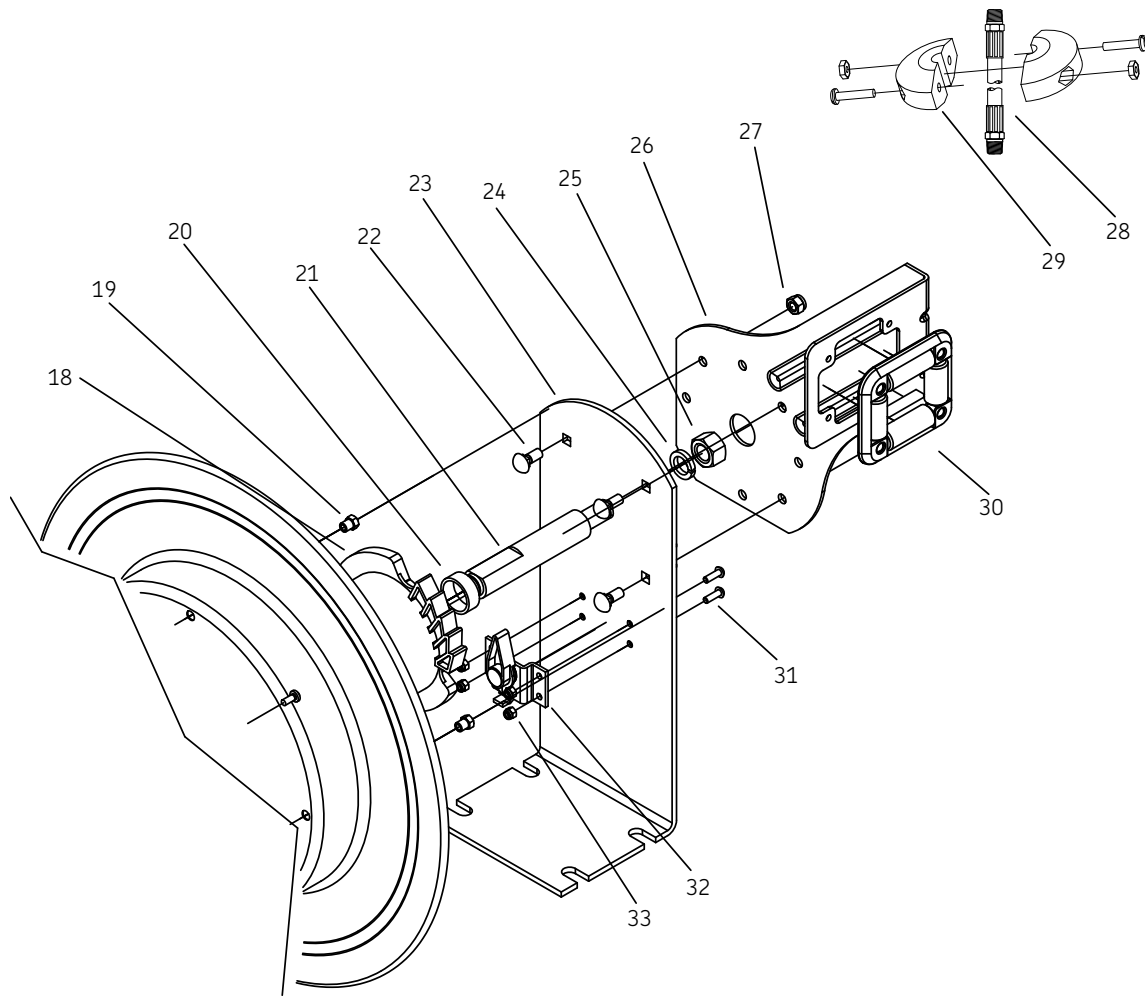

Illustrated parts breakdown

Item no.	Description	Quantity
18	Ratchet and spacer assembly ¹⁾	1
19	Step nut ²⁾	4
20	Main shaft spacer ²⁾	1
21	Main shaft ²⁾	1
22	Bolt GB/T 12 M8 x 18 ²⁾	4
23	Base ²⁾	1
24	Washer GB/T 93 16 ²⁾	1
25	Nut GB/T6170 M16	1
26	Guide arm ²⁾	1
27	Nyloc nut M8 ²⁾	4
28	Hose assembly ¹⁾	1
29	Bumper assembly ¹⁾	1
30	Universal roller ²⁾	1
31	Screw M5 x 12 ²⁾	4
32	Latch pawl assembly ¹⁾	1
33	Nyloc nut M5 ²⁾	5

¹⁾ Refer to service parts table on page 5 for part numbers.

²⁾ Not available for order.

This page intentionally left blank.

This page intentionally left blank.

This page intentionally left blank.

Lincoln industrial standard warranty

Standard limited warranty

Lincoln warrants the equipment manufactured and supplied by Lincoln to be free from defects in material and workmanship for a period of one (1) year following the date of purchase, excluding there from any special, extended, or limited warranty published by Lincoln. If equipment is determined to be defective during this warranty period, it will be repaired or replaced, within Lincoln's sole discretion, without charge.

This warranty is conditioned upon the determination of a Lincoln authorized representative that the equipment is defective. To obtain repair or replacement, you must ship the equipment, transportation charges prepaid, with proof of purchase to a Lincoln Authorized Warranty and Service Center within the warranty period.

This warranty is extended to the original retail purchaser only. This warranty does not apply to equipment damaged from accident, overload, abuse, misuse, negligence, faulty installation or abrasive or corrosive material, equipment that has been altered, or equipment repaired by anyone not authorized by Lincoln. This warranty applies only to equipment installed, operated and maintained in strict accordance with the written specifications and recommendations provided by Lincoln or its authorized field personnel.

This warranty is exclusive and is in lieu of any other warranties, express or implied, including, but not limited to, the warranty of merchantability or warranty of fitness for a particular purpose. Warranty on items sold by Lincoln, but not manufactured by Lincoln are subject to the warranty consideration, if any, of their manufacturer (such as hoses, hydraulic and electric motors, electrical controllers, etc.) Assistance in making such warranty claims can be offered as required.

In no event shall Lincoln be liable for incidental or consequential damages. Lincoln's liability for any claim for loss or damages arising out of the sale, resale or use of any Lincoln equipment shall in no event exceed the purchase price. Some jurisdictions do not allow the exclusion or limitation of incidental or consequential damages, therefore the above limitation or exclusion may not apply to you.

This warranty gives you specific legal rights. You may also have other rights that vary by jurisdiction.

Customers not located in the Western Hemisphere or East Asia: Please contact Lincoln GmbH and Co. Kg, Walldorf, Germany, for your warranty rights.

Special limited warranties

Special limited 2 year warranty SL-V series, single injectors – 85772, 85782, and replacement injectors – 85771, 85781

Lincoln warrants the SL-V Injector series to be free from defects in material and workmanship for two (2) years following the date of purchase. If an injector model (single or replacement) is determined to be defective by Lincoln, in its sole discretion, during this warranty period, it will be repaired or replaced, at Lincoln's discretion, without charge.

Special limited 5 year warranty series 20, 25, 40 bare pumps, pmv bare pumps, heavy duty and 94000 series bare reels

Lincoln warrants series 20, 25, 40 bare pumps, PMV bare pumps, heavy duty (82206), mini bench (81133, 81323), and all 94000 LFR series (single arm and dual arm) bare reels to be free from defects in material and workmanship for five (5) years following the date of purchase. If equipment is determined by Lincoln, in its sole discretion, to be defective during the first year of the warranty period, it will be repaired or replaced at Lincoln's discretion, without charge. In years two (2) and three (3), the warranty on this equipment is limited to repair with Lincoln paying parts and labor only. In years four (4) and five (5), the warranty on this equipment is limited to repair with Lincoln paying for parts only.

Special limited 5 year warranty limited oil meters, limited fluid control valves, aod (air-operated diaphragm pumps)

Lincoln warrants the 712 series control valves, 912 series lube meters, electronic lube meters (980, 981, 982 series), our universal inline digital meters (812/813 series), and our AOD pump offering to be free from defects in material and workmanship for five (5) years following the date of purchase. If either is determined to be defective by Lincoln, in its sole discretion, during the warranty period, they will be repaired or replaced, at Lincoln's discretion, without charge.

Special DEF (diesel exhaust fluid) limited warranty

DEF products are warranted to be free from defects in material and workmanship for a period of one (1) year following the date of purchase. The following exceptions to the standard warranty period are in effect:

- **85700-30/85700-50 DEF hose reels (bare reel only),** 277251/277252 AC DEF pumps, and 277256 and 277257 DEF meters are warranted for two (2) years from date of purchase.
- **85623 DEF AOD (air operated diaphragm) pumps** are covered under the standard five (5) year AOD pump warranty. If either is determined to be defective by Lincoln, in its sole discretion, during the warranty period, they will be repaired or replaced, at Lincoln's discretion, without charge.

Lincoln Industrial contact information

To find Lincoln Industrial's nearest service center call the following number; customer service 314-679-4200 (international number 01-314-679-4200) or you may also use our website www.lincolnindustrial.com

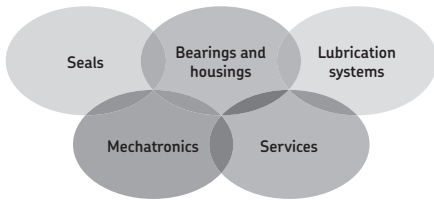

The Power of Knowledge Engineering

Combining products, people, and application-specific knowledge, SKF delivers innovative solutions to equipment manufacturers and production facilities in every major industry worldwide. Having expertise in multiple competence areas supports SKF Life Cycle Management, a proven approach to improving equipment reliability, optimizing operational and energy efficiency and reducing total cost of ownership.

These competence areas include bearings and units, seals, lubrication systems, mechatronics, and a wide range of services, from 3-D computer modelling to cloud-based condition monitoring and asset management services.

SKF's global footprint provides SKF customers with uniform quality standards and worldwide product availability. Our local presence provides direct access to the experience, knowledge and ingenuity of SKF people.

© SKF is a registered trademark of the SKF Group.

© Lincoln is a registered trademark of Lincoln Industrial Corp.

© SKF Group 2014

The contents of this publication are the copyright of the publisher and may not be reproduced (even extracts) unless prior written permission is granted. Every care has been taken to ensure the accuracy of the information contained in this publication but no liability can be accepted for any loss or damage whether direct, indirect or consequential arising out of the use of the information contained herein.

SKF PUB LS/l1 14723 EN.R1 - June 2014 - Form 404665A.

