

FOR BEARINGS WITH 1" TO
9 1/2" O.D. x 9/16" I.D. MIN.
FOR USE WITH 25
OR 35 LB. CONTAINER.

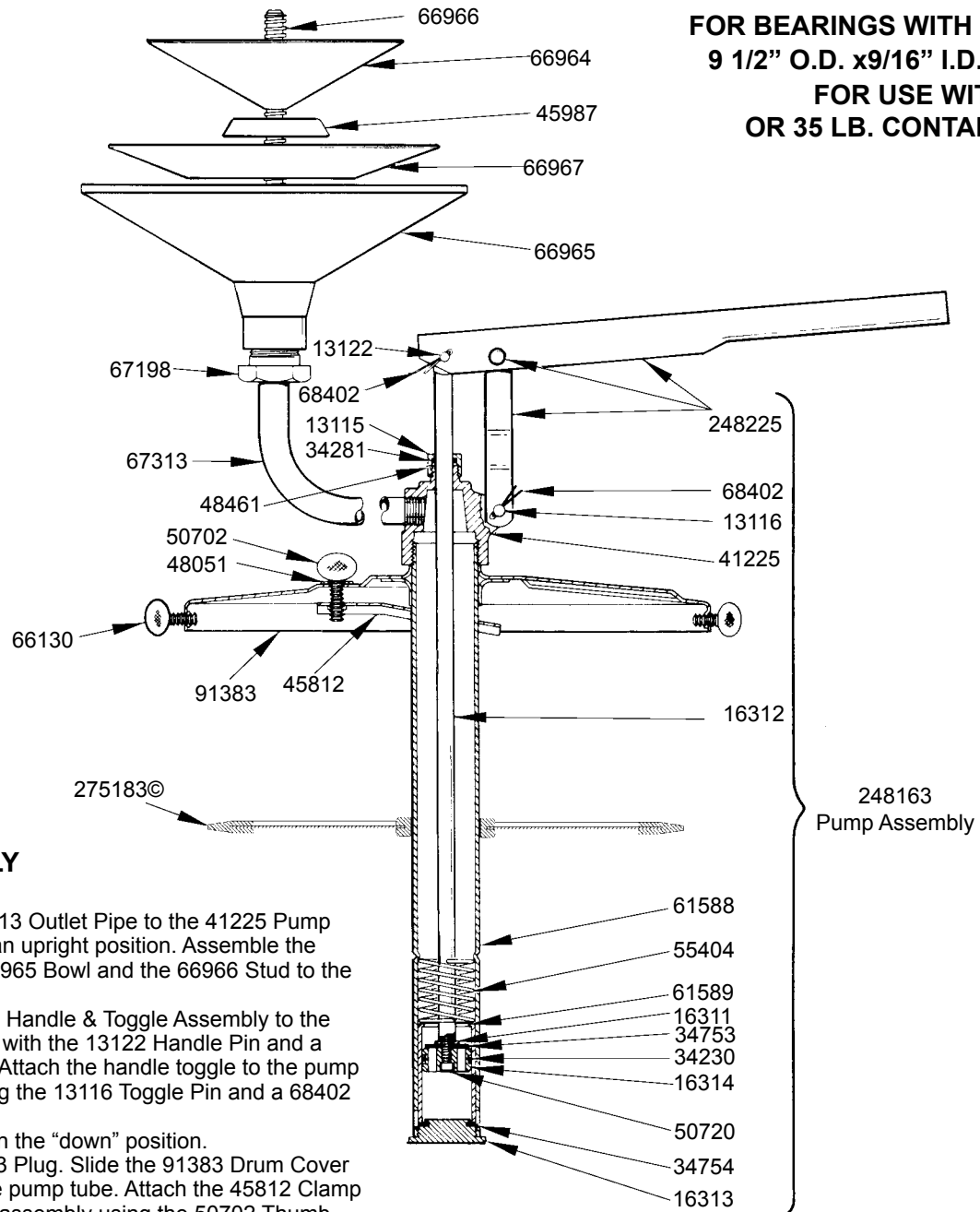

PUMP ASSEMBLY

- 1) Assemble the 67313 Outlet Pipe to the 41225 Pump Outlet Casting in an upright position. Assemble the 67198 Adapter, 66965 Bowl and the 66966 Stud to the outlet pipe.
- 2) Attach the 248225 Handle & Toggle Assembly to the 16312 Piston Rod with the 13122 Handle Pin and a 68402 Cotter Pin. Attach the handle toggle to the pump outlet casting using the 13116 Toggle Pin and a 68402 Cotter Pin.
- 3) Place the handle in the "down" position.
- 4) Remove the 16313 Plug. Slide the 91383 Drum Cover Assembly onto the pump tube. Attach the 45812 Clamp to the drum cover assembly using the 50702 Thumb Screw and 48051 Washer. Do not tighten thumb screw, the pump tube should slide freely through clamp & drum cover.
- 5) Slide the 275183© Follower Assembly onto the pump tube.
- 6) With handle remaining in the down position, insert the 16313 Plug into the pump tube and hand tighten.
- 7) Assemble the three 66130 Thumb Screws into the drum cover rim.
- 8) Remove lubricant container cover, push pump tube a short distance into lubricant at center of the container and guide the 275183© Follower Assembly into the container. Position the drum cover over the rim of the lubricant container and secure with the three thumb screws.
- 9) Push pump tube down through the drum cover until pump rests on lubricant container bottom. Secure the pump by tightening the 50702 Thumb Screw on top of the drum cover.

© Indicates change

LUBRICANT SELECTION

Model 102929 Wheel Bearing Packer will prime easily and pump efficiently when using heavy greases at low temperatures; from a normal condition of NLGI #2 grease or less at 70° F to an extreme condition of NLGI #2 grease at 20° F.

A slight pause should be allowed at the end of the downstroke of the handle to allow the grease to flow into the pump tube. In extreme conditions (#5 grease at 20° F) the handle should remain at the end of the downstroke for approximately 5 seconds.

PRIMING

- 1) Remove 66965 Bowl from 67313 Outlet Pipe.
- 2) Operate handle until lubricant flows from outlet pipe.
- 3) If pump will not prime, pour approximately two ounces of clean lightweight oil into the outlet pipe and repeat step two.
- 4) Replace cup and tighten securely.

INSTRUCTIONS

Remove 66964 Top Nut and 66967 Adapter. Position bearing on 66965 Bowl so the outer race of bearing will seal on bowl. Reassemble 66964 Top Nut and turn down tightly to assure seal on inner race of bearing. Operate pump slowly until grease extrudes around balls or rollers.

NOTES

- 1) When lubricating bearings with an inside diameter of over 5-1/2 inches, it will be necessary to use the 66967 Adapter to assure seal on inner race.
- 2) When lubricating bearings with an outside diameter of 1 inch to 1-3/4 inches, it will be necessary to use the 45987 Adapter.

TROUBLESHOOTING

PROBLEM: No output from pump.
CAUSE: Lubricant container is empty.
PROCEDURE: Fill lubricant container.

PROBLEM: Insufficient output volume.
CAUSE: 1) Foreign particles may be lodged in slide valve or in between the piston and check.
 2) Slide valve return spring may be broken.
 3) O-ring may be worn.

PROCEDURE: 1) Remove 61589 Slide Valve and/or 16314 Piston and 34753 Check. Clean and reassemble.
 2) Replace 55404 Spring.
 3) Replace 34230 O-ring.

PROBLEM: Lubricant leaks around piston rod at top of the pump.
CAUSE: Gland packing is worn.
PROCEDURE: Replace 34281 Gland Packing.

SERVICE PARTS

Part	Qty.	Description	Part	Qty.	Description
13115	1	Gland nut	50720	1	Screw
13116	1	Toggle pin	55404	1	Spring
13122	1	Handle pin	61588	1	Pump tube
16311	1	Retainer	61589	1	Slide valve
16312	1	Piston rod	66130	3	Thumb screw
16313	1	Plug	66964	1	Top nut
16314	1	Piston	66965	1	Bowl
34230	1	O-ring	66966	1	Stud
34281	1	Gland packing	66967	1	Adapter
34753	1	Check	67198	1	Bushing
34754	1	Gasket	67313	1	Outlet pipe
41225	1	Pump outlet casting	68402	2	Cotter pin
45812	1	Clamp	84359	1	Pump assembly
45987	1	Adapter	91382	1	Handle & toggle assembly
48051	1	Washer	91383	1	Drum cover assembly
48461	1	Washer	275183©	1	Follower assembly
50702	1	Thumb screw			

© Indicates change

Americas:
 One Lincoln Way
 St. Louis, MO 63120-1578
 USA
 Phone +1.314.679.4200
 Fax +1.800.424.5359

Europe/Africa:
 Heinrich-Hertz-Str 2-8
 D-69183 Walldorf
 Germany
 Phone +49.6227.33.0
 Fax +49.6227.33.259

Asia/Pacific:
 51 Changi Business Park
 Central 2
 #09-06 The Signature
 Singapore 486066
 Phone +65.6588.0188
 Fax +65.6588.3438

© Copyright 2006
 Printed in USA

Web site:
www.lincolnindustrial.com