

CUT-OFF WHEELS/MANDRELS

TYPE 1

12" & 14" CHOP SAW BLADES

Item#	Old#	Size	Thickness	Arbor	Grit	RPM	Reinforcement/Type	Grain	Pk. Qty	MP
124D		12"	3/32"	1"	36	5,000	Double	Aluminum Oxide	1	6
124-5		12"	3/32"	1"	36	5,000	Double	Aluminum Oxide	5	10
121-5		12"	1/8"	1"	36	5,100	Single	Aluminum Oxide	5	6
12726	122	12"	1/8"	1"	36	6,300	Double	Aluminum Oxide	1	5
12727		12"	1/8"	1"	36	6,300	Double	Aluminum Oxide	10	3
122-5		12"	1/8"	1"	36	6,300	Double	Aluminum Oxide	5	6
123-5		12"	7/64"	1"	36	5,100	Single	Aluminum Oxide	5	6
13058		12"	5/32"	20mm	24	6,400	Double/H.S. Gas/Elect. Saws	Zirconia	5	6
13059		12"	5/32"	1"	24	6,400	Double	Aluminum Oxide	5	6
12696	122M	12"	1/8"	1"	36	5,100	Double/Masonry	Silicon Carbide	1	5
12697		12"	1/8"	1"	36	5,100	Double/Masonry	Silicon Carbide	10	3
122M-5		12"	1/8"	1"	36	5,100	Double/Masonry	Silicon Carbide	5	6
141-5		14"	1/8"	1"	36	4,400	Single	Aluminum Oxide	5	6
13159	144-5	14"	3/32"	1"	36	4,400	Double	Aluminum Oxide	5	6
12728	142	14"	1/8"	1"	36	4,400	Double	Aluminum Oxide	1	5
12729		14"	1/8"	1"	36	4,400	Double	Aluminum Oxide	10	3
12663	142-5	14"	1/8"	1"	36	4,400	Double	Aluminum Oxide	5	6
143-5		14"	7/64"	1"	36	4,400	Double	Aluminum Oxide	5	6
13060		14"	5/32"	20mm	24	5,460	Triple/H.S. Gas/Elect. Saws	Aluminum Oxide	5	6
13061		14"	5/32"	1"	24	5,400	Triple/H.S. Gas/Elect. Saws	Aluminum Oxide	5	6
12698	142M	14"	1/8"	1"	24	4,400	Double/Masonry	Silicon Carbide	1	5
12699		14"	1/8"	1"	24	4,400	Double/Masonry	Silicon Carbide	10	3
142M-5		14"	1/8"	1"	24	4,400	Double/Masonry	Silicon Carbide	5	6
142MH-5		14"	1/8"	1"	24	4,400	Double/HD Masonry	Silicon Carbide	5	6

12782

Mandrel for 14607 Strip-Brite Disc (p. 34)



12431 (31)

Mandrel with 3/8" shoulder screw



12935 (32)

Mandrel with 1/4" & 3/8" shoulder screw



12433 (33)

Mandrel with 3/8" Extended Shoulder Screw. For use with wheels thicker than 3/8" with 3/8" arbor hole



12693 (34)

Mandrel with 1/2" adaptor



37L

Mandrel with 1/4" extended screw for wheels thicker than 3/8"



37S

Mandrel with only a 1/4" shoulder screw



MANDRELS/ADAPTORS

DEPRESSED CENTER WHEEL ADAPTOR

Adaptor readily adapts any depressed center wheel with 7/8" hole to a 5/8"-11NC spindle for use with a standard right angle grinder. Wrench included.

13213 Kit Includes: Wrench, Adaptor, 2 washers and nut.



MANDRELS

Shark mandrels can be used to convert any die grinder into a cut-off tool using wheels with either 1/4" or 3/8" I.D. Be sure to wear proper eye protection/face mask, gloves and safety gear.

Shark offers 7 different types of Mandrels for any application.

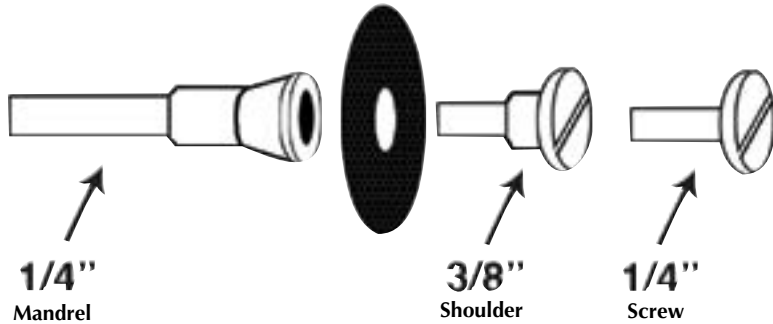

12782
Mandrel for 14607 Strip-Brite Disc (p. 34)

12431 (31)
Mandrel with 3/8" shoulder screw

12935
Mandrel with 1/4" & 3/8" shoulder screw

12433
Mandrel with 3/8" Extended Shoulder Screw. For use with wheels thicker than 3/8" with 3/8" arbor hole

12693 (34)
Mandrel with 1/2" adaptor

37L
Mandrel with 1/4" extended screw for wheels thicker than 3/8"

37S
Mandrel with only a 1/4" shoulder screw