

## 12270 Cooling System Tester and Adapters

**The 12270 30 pound cooling system and pressure cap tester, tests up to 30 pound cooling systems and pressure caps.**

The Stant 12270 tester lets you test today's cars higher pressure cooling systems and pressure caps up to 30 pounds.

The 12270 gauge includes additional cap testing pressure ranges of 17-19 lbs., 20 lbs., and 28-30 lbs. The large color coded dial makes it easy to accurately test these higher pressure caps and systems.

The 12270 head also includes a pressure release bar that when turned clockwise, releases pressure buildup before removing the head from the neck.

Although the 12270 tester replaces our 12255, all Stant pressure cap and cooling system adapters can be used on either tester. We've even created a conversion kit, 12701, that allows you to convert your 12255 to a 12270.

The 12270 pressure tester comes in its own plastic carrying case with one 12559 spacer to drop in 1" deep filler necks for testing, one 12552 cap adapter to check Standard "A" Size caps, and a complete easy to use instruction manual including cooling system and pressure cap testing instructions as well as usage instructions and applications for all Stant adapters.

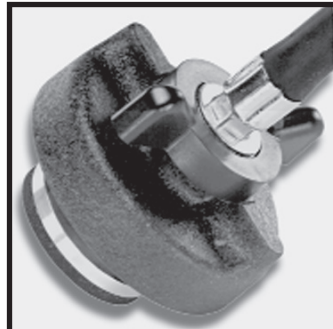

**PRESSURE RELEASE BAR**



**12701 Conversion kit**  
Allows you to update your 12255 tester to the 30 pound 12270.

The 12701 kit includes a 30 pound gauge, hose and head assembly including the pressure release bar and 30 pound spring, and the 12270 instruction manual.



### **Tester Adapter Carrying Case**

12001 is a convenient way to store and carry your tester adapters. The 12001 tester adapter carrying case is constructed of durable plastic. A molded corner pocket is also included for small parts and gaskets. Keep all your Stant tester adapters clean, dry, handy and organized.

## 12270 Cooling System Tester and Adapters



**12453 kit** includes a 12452 rubber gasket and the "B" size filler neck adapter from the 12450 truck adapter kit. This is the complete separate kit for testing GM X-cars with the 2.5L engine and J-cars with the 1.8L and 2.0L engine.



**12552 cap adapter** for use with 12270 tester to check  $\frac{3}{4}$ " deep caps. (Both ends of adapter are  $\frac{3}{4}$ " deep.) (Vehicles using the Stant 10208, 10226, 10228, 10229, 10230, 10231, 10234, 10235, 10237, 10308, 10328, 10329, 10330, 10331, 10334, 10335, 10337 radiator caps). No adapter is required to test the cooling systems on these vehicles.

## 12270 Cooling System Tester Repair Parts

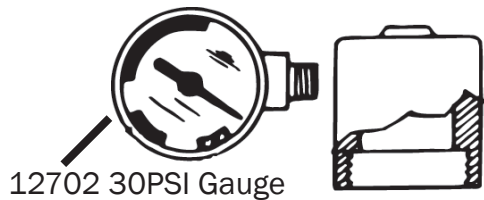

12702 30PSI Gauge



12553 Check Valve

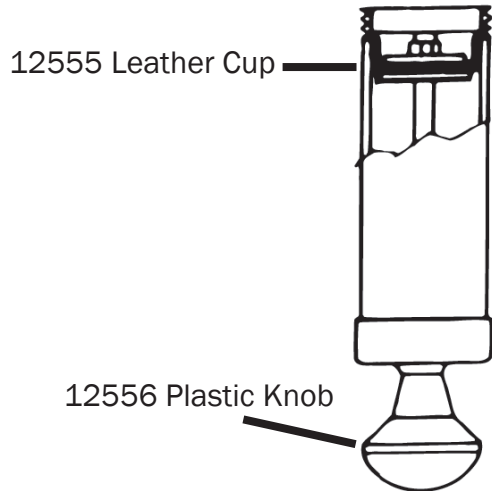

12555 Leather Cup

12556 Plastic Knob



12559 SPACER - Drop in 1" deep filler necks for testing.



12703 HEAD REPAIR KIT - includes 12559 spacer. Use this kit with the 12270 30 pound tester.



12704 HOSE AND HEAD KIT - for use with 12555 or 12270 tester. Includes 12559 spacer/washer for 1" deep filler necks.

**Popular  
Heavy  
Duty  
Applications**

Vehicle	Year	System Adap.	Cap Adap.
Chevrolet/GMC	1999 - newer	12032	12033
Chevrolet/GMC w 2 1/2" filler neck		12015	
Ford w/threaded neck	1995 - newer	12026	12029
Freightliner	2006 - newer	12032	12033
IHC	1994-2002	12026	12029
IHC	2003 - newer	12032	12033
Kenworth	2005 - newer	12026	12029
Mack Pinnacle & some others		12016	12017
Peterbilt		12026	12029
Sterling/White	1995 - newer	12026	12029
Volvo	2000 - newer	12042	
Volvo VN		12016	12017
White w 2 1/2" filler neck		12015	

# Cooling System Adapter Chart for Radiator Caps

10208	12552	System Adapter on Tester	10262	None	12043
10225	12017	12016	10264	12021	12027
10226	12552	System Adapter on Tester	10265	12021	12027
10227	12021	12027	10267	12021	12027
10228	12552	System Adapter on Tester	10268	12021	12027
10229	12552	System Adapter on Tester	10269	12033	12032
10230	12552	System Adapter on Tester	10270	12029	12026
10231	12552	System Adapter on Tester	10271	12033	12032
10233	12021	12027	10281	12450	12450
10234	12552	System Adapter on Tester	10282	12450	12450
10235	12552	System Adapter on Tester	10283	12450	12450
10237	12552	System Adapter on Tester	10292	12450	12450
10238	12029	12026	10293	12450	12450
10239	12029	12026	10294	12450	12450
10240	12029	12026	10327	12021	12027
10241	12024	12025	10328	12552	System Adapter on Tester
10242	12024	12025	10329	12552	System Adapter on Tester
10243	None	12028	10330	12552	System Adapter on Tester
10244	None	12018	10331	12552	System Adapter on Tester
10245	None	12018	10333	12021	12027
10246	None	12030	10334	12552	System Adapter on Tester
10247	None	12030	10335	12552	System Adapter on Tester
10248	12033	12032	10337	12552	System Adapter on Tester
10249	12037	12036	10361	12021	12027
10250	12035	12034	10362	12021	12027
10251	12041	12040	10371	12552	System Adapter on Tester
10252	None	12018	10372	12552	System Adapter on Tester
10253	12039	12038	10373	12552	System Adapter on Tester
10255	None	12019	10381	12552	System Adapter on Tester
10257	12029	12026	10382	12552	System Adapter on Tester
10258	12029	12026	10391	12552	System Adapter on Tester
10259	12033	12034	10392	12552	System Adapter on Tester
10260	None	12018	10393	12552	System Adapter on Tester
10261	None	12023	10394	12552	System Adapter on Tester

## ADAPTER ASSORTMENTS



10022 - Popular cap and system adapter set includes:  
12021, 12026, 12027, 12029, 12032, 12033

10042 - Ford/Mercury adapter set includes:  
12021, 12026, 12027, 12029, 12034, 12035, 12041

10043 - GM adapter set includes:  
12021, 12023, 12024, 12025, 12026, 12027, 12029, 12032, 12033

10044 -Chrysler/Dodge ; Honda/Acura; Toyota/Lexus includes:  
12021, 12024, 12025, 12027

10045 -Nissan/Infiniti adapter set includes:  
12021, 12026, 12027, 12029

10046 -VW, Porsche, Audi adapter set includes:  
12016, 12017, 12028, 12036, 12037

10047 - Heavy Duty Truck assortment includes:  
12015, 12026, 12029, 12032, 12033, 12042, 12450

12004\* - Tester adapter assortment includes:  
12025, 12026, 12027, 12032, 12034, 12001 Case

**\* Most popular system adapters AND includes case**