



PARTS LIST

Masker/Multi-Roll

Part #78007

PART#	DESCRIPTION	QUANTITY
10717	Leg - Left	1
10718	Leg - Right	1
10727	Cross Member - Upper	2
10728	Cross Member - Lower	1
10218	1/4" Flat Washer	38
10675	1/4"-20 X 2" Bolt	6
10714	1/4"-20 X 4" Bolt	4
10672	Tape Reel with Insert	4
10178	1/4"-20 Lock Nut	8
10726	Axle	1
10729	Axle Cover - Outer	2
10730	Axle Cover - Middle	1
4022500	6" Wheel	2
10705	Hub Cap	2
10201	1/4"-20 Hex Nut	12
10687	18" Cutter Blade	2
10689	S - Hook	8
10685	11 1/4" Extension Spring	2
10671	24" Cutter Blade	2
10669	15 3/4" Extension Spring	2
10676	1/4"-20 X 1 1/2" Bolt	8
10680	Paper Bar Collar	8
10677	Paper Bar Washer	8
10221	Paper Bar Spring	4
10688	Tubing Cap	4

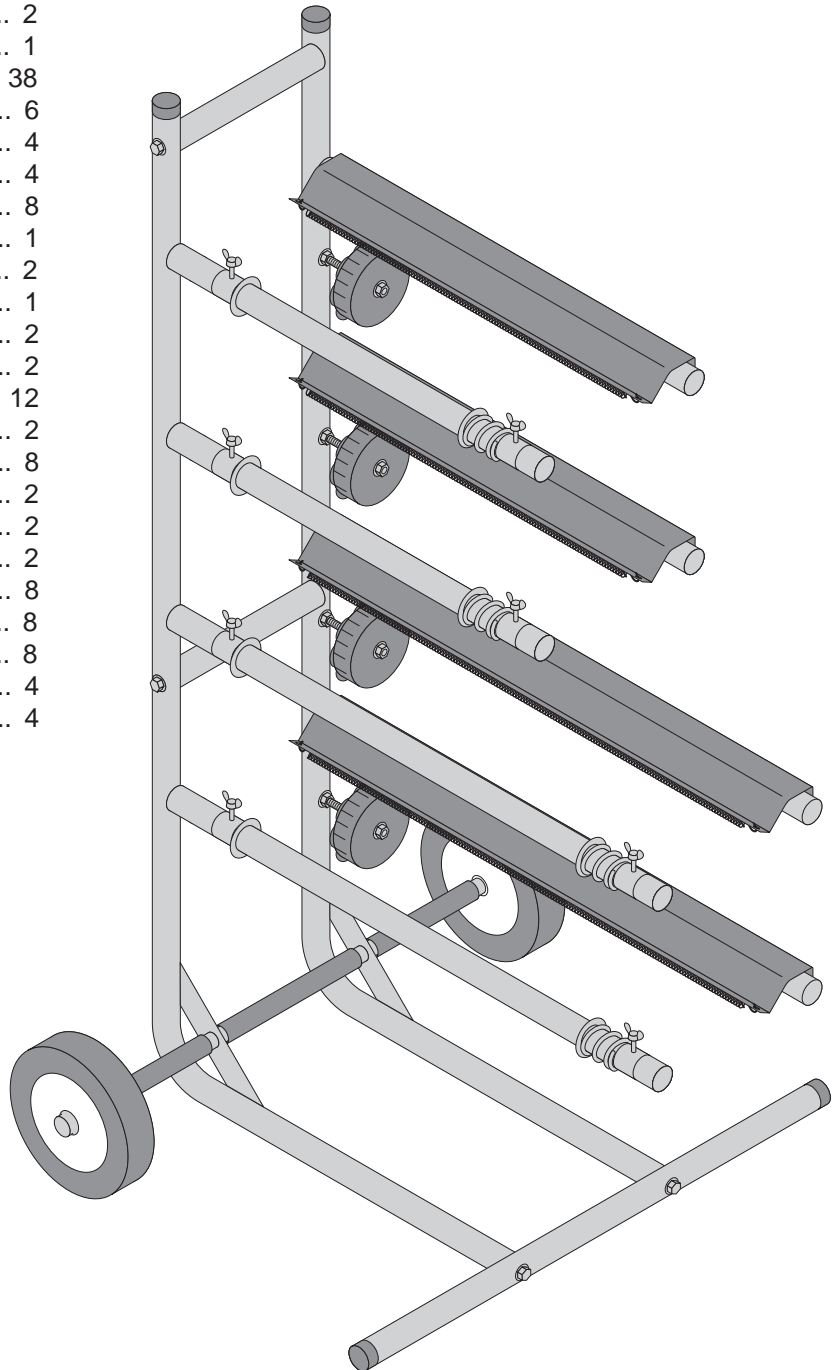

STEP 1. Assemble the main frame tubing using 1/4"-20 X 2" Bolts and 1/4" Flat Washers either while vertical or lying on the ground. **Note the locations of all punched holes** in all tubing to ensure proper assembly.

STEP 2. Assemble and install the Tape Spool assemblies.

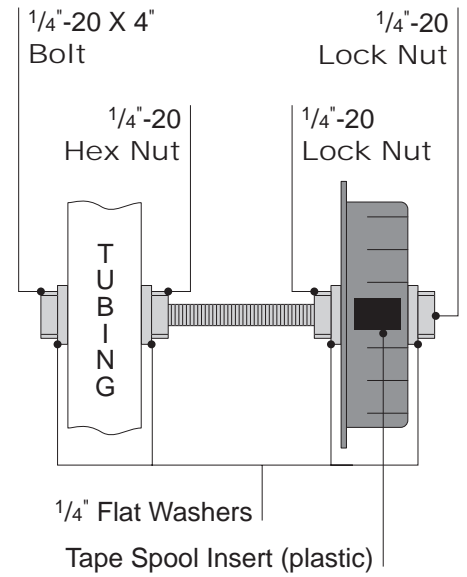

STEP 3. Install Axle, Axle Covers, Wheels, and Hubcaps.

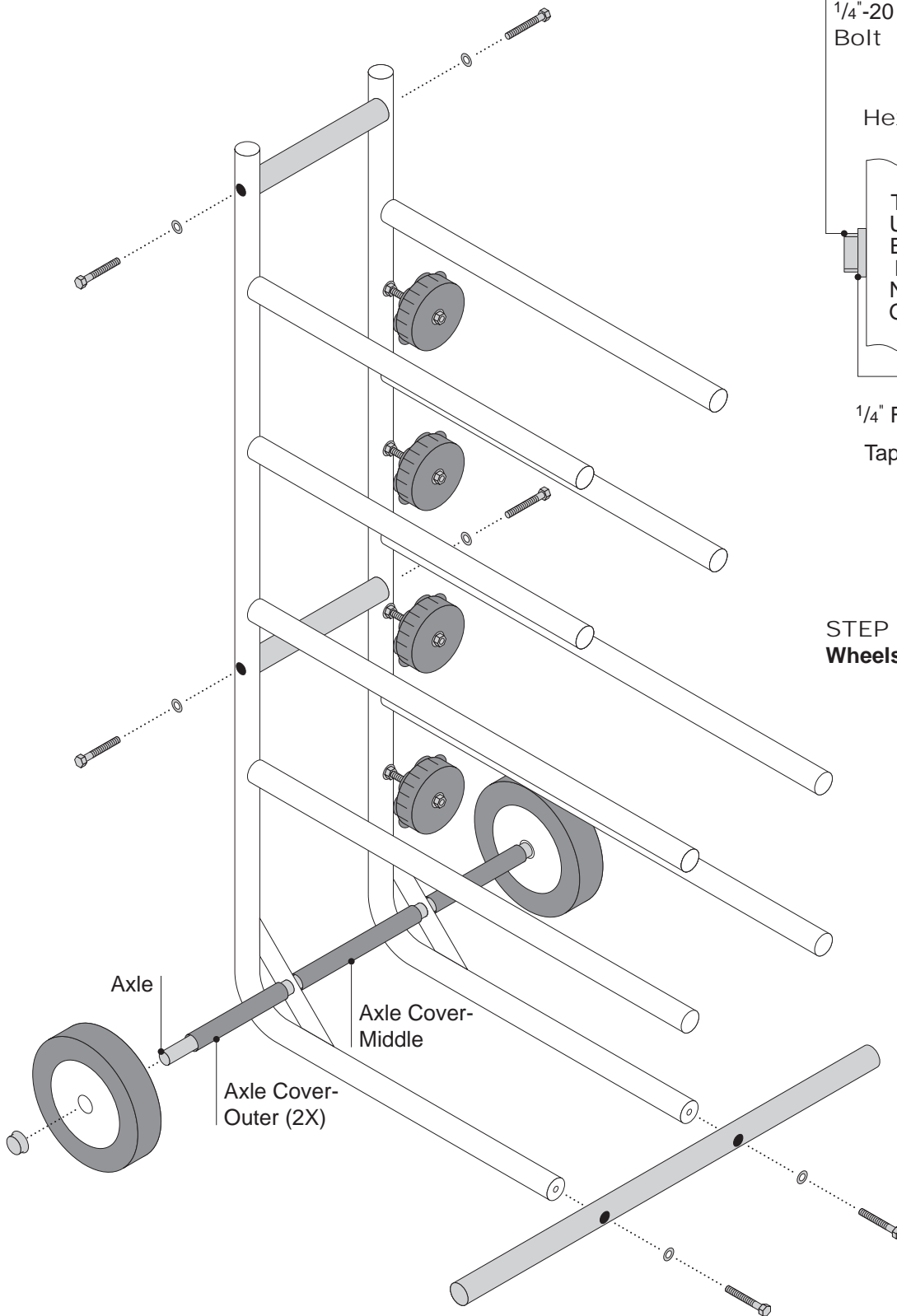

STEP 4. Install the Cutter Bar assemblies and Tubing Caps. First, attach the supplied S-Hooks to each end of the Extension Spring. Next, attach the Extension Spring to the **BOTTOM** of the Cutter Bar Blade. Lastly, you will use two 1/4"-20 X 1 1/2" Bolts, four 1/4" Flat Washers and two 1/4"-20 Hex Nuts to attach each Cutter Blade assembly onto the main frame tubing. **NOTE:** Ensure that the cutting edge is on the **OUTSIDE** and facing **DOWN** as shown and that the Extension Spring is **NOT** visible from the top.

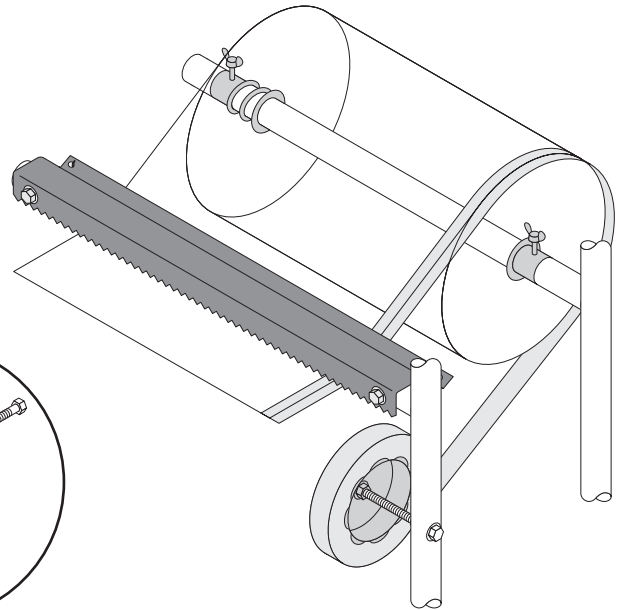
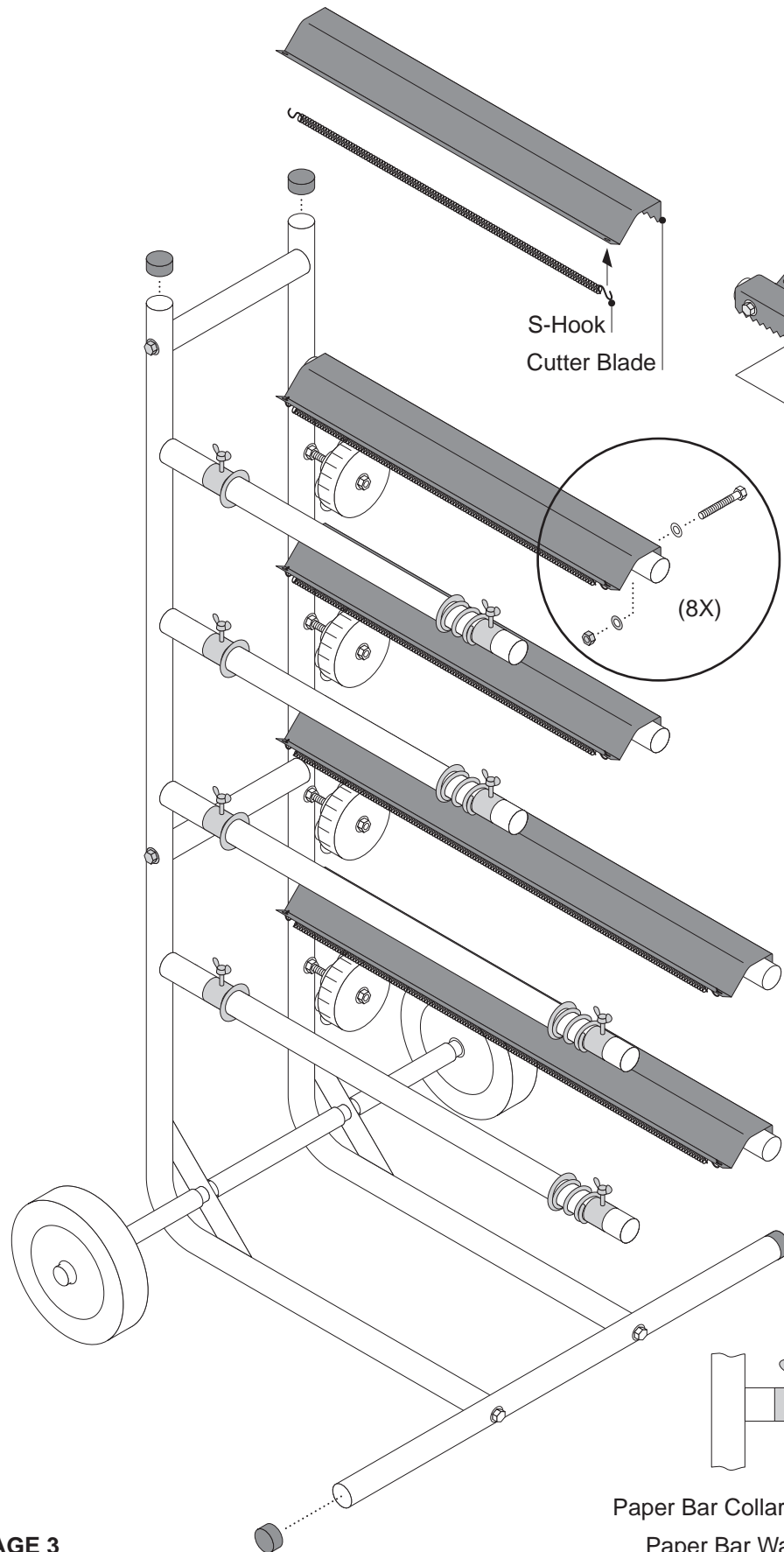

Travel direction of paper and tape, locations of Springs, Washers and Collars. (Reverse View)

Secure taped paper between Spring and Cutter Blade.

STEP 5. Install Paper Bar hardware.

Push Paper Bar Washer, Spring, and Collar against paper roll and tighten to desired tension.

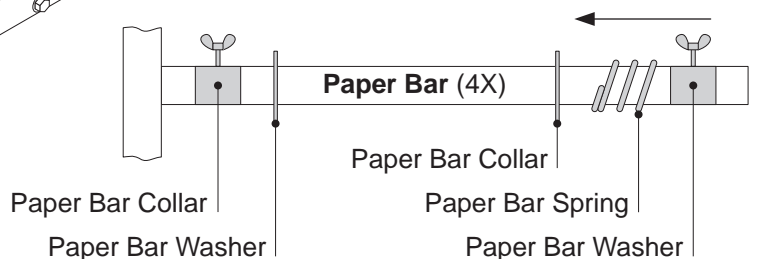

PART NUMBER BREAKDOWN for ORDERABLE PARTS

NOTE: EVERY part is orderable. If you do NOT see an item called out in this illustration (such as specific nuts, bolts, washers etc.) refer to the **parts list** and contact S&H Industries to happily assist in your order.

