



VIDEO  
INSTRUCTIONS

20175

# Heavy Duty Driveline Service Kit

## // Safety Warning

**Read all instructions and safety warnings prior to operation.**

**Failure to do so could result in equipment damage, personal injury, or even death.**

**CAUTION:** Failure to check the spherical thrust washer and replace as necessary may result in unrepairable damage to your u-joint puller glove casting. Preventative maintenance as outlined below will ensure many years of use from your tiger tool puller. Failure to perform preventative maintenance will void your warranty.

- Stay Alert! Watch what you are doing and use common sense when operating this tool.
- Inspect product for damage prior to using; do not use if product is in unsafe condition.
- Do not operate tool while under the influence of drugs, alcohol, or medication.
- Always use safety equipment to prevent injuries. Approved face and eye protection must always be worn by the operator, as well as others in the work area.
- Do not overreach. Keep proper footing and balance at all times.
- Dress properly. Do not wear loose clothing or jewelry.
- Keep your hair, clothing and gloves away from moving parts.
- Keep hands clear of all pressurized hydraulic components.
- Always ensure hoses are free from sharp bends and kinks.
- Keep your work area clean and well lit.
- Cylinders are designed for 10,000 psi (700 bar) maximum working pressure. Do not connect to a pump with a higher rated pressure. Use a pressure gauge in the system at all times. Ensure all components in the system are rated for 10,000 psi (700 bar).

Tiger Tool International Incorporated Warranty and Limit of Liability Terms and Conditions. For more information, visit [tigertool.com](http://tigertool.com)

**Warranties: 1)** Tiger Tool International Incorporated ("Tiger Tool") warrants to customers who purchase the tools from Tiger Tool or an authorized dealer of Tiger Tool that cast portions of the tools are free from defects in workmanship and materials at the time of sale and for as long as the original customer owns the tool pursuant to a contract of sale between the customer and Tiger Tool or its authorized dealer. **2)** Tiger Tool warrants to its customers that threaded areas, bolts and machined components in or of the tools will not fail as a direct result of and caused solely due to defects in workmanship and materials not known at the time of purchase and not discovered by the purchaser or anyone on behalf of the purchaser for a period of two years from the date of original purchase. **3)** Tiger Tool warrants to its customers that hydraulic components will not fail as a direct result of and caused solely by defects in workmanship and materials for a period of one year from the date of original purchase. **4)** Tiger Tool makes no other warranty regarding the fitness for purpose, use, quality, merchantability, or functioning of the tools other than as stated in writing in these terms and conditions of warranty.

**Claims on warranty: 5)** In order for tiger tool to assess any claim of warranty the customer of Tiger Tool agrees to deliver the tool to one of the addresses stated in paragraph 6 or such other place as Tiger Tool may designate, at the customer's sole expense such freight being fully pre-paid by the customer to the addresses designated to the customer by Tiger Tool. **6)** U.S. Returns: 115 First Street PMB-T75520, Sumas, WA 98295. Canada returns: 160-34434 McConnell Road, Abbotsford, B.C., V2S 7P1.

**Limit of liability of Tiger Tool: 7)** The limit of liability of Tiger Tool for any claim of warranty made by any customer pursuant to these terms and conditions of warranty is that Tiger Tool may at its option, repair the tool, replace the tool or refund the purchase price for the tool to the customer. Tiger Tool is not liable for any damages or claims, monetary relief or any other damages or claims, including costs and legal costs except as set out in this paragraph. Tiger Tool is not liable for any economic loss, damages for bodily injury, or claims for property damages. The limit of the warranty and the liability of tiger tool to its customer is as set out in this warranty. the warranty does not extend into the secondary market and the limitation of liability set out in this warranty does extend into the secondary market for the tools of Tiger Tool. Tiger Tool is not responsible for any warranty of its tools to customers of its customer or those who otherwise come into possession or use of its tools through or by its original customer. Tiger Tool is not liable for any damages or claims, monetary relief or any other damages or claims, including costs and legal costs and Tiger Tool is not liable for any economic loss, damages for bodily injury, or claims for property damages to customers of its customer or those who otherwise come into possession or use of its tools through or by its original customer. **8)** New unused product that is returned to Tiger Tool with the pre-authorization given by Tiger Tool to its dealer or customer in those circumstances where the purchase of the tool from Tiger Tool by the customer was as a result of the customer's error or due to the customer's inventory adjustment, will be subject to (A) the dealer or customer returning the product in new and unused condition to Tiger Tool at the address designated by Tiger Tool and (B) the dealer or customer paying to Tiger Tool the costs of restocking and reselling the product which the dealer or customer and Tiger Tool agree will be 20% of the purchase price of the tools paid by the dealer or customer to Tiger Tool, which costs must be paid immediately by the dealer or customer to Tiger Tool upon the product being authorized and received by Tiger Tool pursuant to this paragraph. **9)** This warranty is null and void and is of no effect unless the tools purchased by the customer from Tiger Tool or its authorized representative are used in accordance with the terms and conditions of use and the instructions for use published by Tiger Tool in the instructions given with the tool and published on the website of Tiger Tool. **10)** Tiger Tool does not warrant any of its tools that are subject to abnormal use, including without limitation misuse, accident, modification, unreasonable use, neglect, lack of maintenance or use after any portion of a tool is significantly worn. **11)** In the case that Tiger Tool decides that the tools delivered to tiger tool pursuant to a claim made on this warranty do not meet the conditions for any liability of Tiger Tool to perform any obligation pursuant to this warranty, then the customer must at its own expense remove the tools from the premises of Tiger Tool. Tools that are subject to this paragraph and are rejected by Tiger Tool for any claim of warranty will be retained in tiger tool's warehouse facility for four months without any liability of Tiger Tool as a bailee or warehouse of the dealer or customer. These tools will be retained for pick up for four months in the warehouse of Tiger Tool at the sole risk of the dealer or customer, for insurance and loss howsoever caused including by the neglect of Tiger Tool or for anyone it is responsible. Tiger Tool will during the four month period make three attempts to contact the dealer or customer to pick up the tool, and after four months have expired from the first date that Tiger Tool gives notice to the dealer or customer that there is no valid warranty claim for the tools, then the dealer or customer agrees that Tiger Tool may dispose of the tools as it deems necessary, and the dealer or customer quit claims any property or other interest in the tools at the end of that four month period including any claim for refund of purchase price, loss or damage. **12)** Without limiting anything in these terms and conditions of warranty, Tiger Tool shall not be liable for any indirect, consequential, exemplary, incidental, special or other similar damages incurred by a customer or any purchaser or user, or any person or entity who comes into possession of its tools, except for the warranties specifically between the customer and Tiger Tool as set out in paragraphs 1, 2 and 3 above. Tiger Tool is not in any case in any event in any circumstances whatsoever, liable for claims for lost profits, lost revenues, lost sales, lost business opportunities, lost or damaged goodwill, interruption of business or any other injury or damage to person or property howsoever connected to the possession or use of its tool(s). **13)** The terms and conditions of warranties by Tiger Tool and the limits of liability as set out in these terms and conditions of warranty represent the sole and exclusive remedies of the customer and are in place of all other rights and remedies that the customer of Tiger Tool may have. **14)** Tiger Tool reserves the right to change the design and construction of its tools at any time without any obligation to any customer who has purchased the tool or any user of the tool. Tiger Tool may in its sole discretion discontinue the sale or service of any tool at any time without obligation to any customer or user of the tool. **15)** Any dispute, claim or other demand made by a customer or any party against Tiger Tool, arising out of this agreement, or regarding the sale, use, condition, or function of a tool sold by tiger tool shall be governed by the laws of British Columbia and such disputes, including any dispute brought by class or representative proceedings, shall be adjudicated in Vancouver, British Columbia by a sole arbitrator appointed pursuant to the provisions of the arbitration act R.S.B.C. 1996, C. 55, (as amended). Any party including any customer making any claim whatsoever against Tiger Tool arising of this warranty or otherwise hereby attorns to the jurisdiction of the province of British Columbia and agrees to the arbitration of those claims in Vancouver, British Columbia.

**TIGER TOOL**®

**Canada**  
160-34434 McConnell Road,  
Abbotsford, BC V2S 7P1

**USA**  
115 First Street, PMB-T75520  
Sumas, WA 98295

**Technical Support**  
1.800.661.4661  
[tigertool.com](http://tigertool.com)

# Operating Instructions

View the Heavy Duty U-Joint Puller demonstration online at [tigertool.com](http://tigertool.com)

**NOTE:** Hammering this tool will void your warranty.

VIDEO  
INSTRUCTIONS



## Using the 10102

- 1 Remove all fastener/retainers from bearing cups.
- 2 Slip the U-Joint Puller over the yoke of the drive line.
- 3 Turn the tool's forcing screw clockwise with either an air or hand wrench.  
**NOTE:** reverse thread.
- 4 The 10102 U-Joint Puller may be used with up to a 1" impact wrench without voiding warranty.

## Preventative Maintenance

Keep forcing screw clean and lubricated at all times. Failure to maintain the spherical thrust washer located inside the glove (Item 5) will result in excessive wear to the glove. Check and lubricate this part (lubricate load bearing surface in glove, under cap, on both sides of spherical washer) periodically and replace as necessary. Contact your Dealer or Tiger Tool for replacement washers. (We recommend SAE 30 lube for the threads and EP molly grease for the spherical washer.)

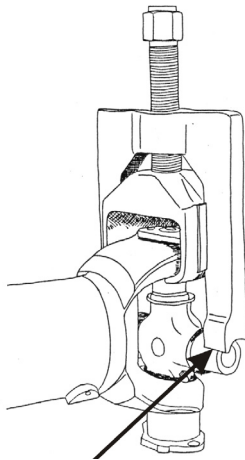

The leg design allows you to push on the driveline or on the U-Joint cross. (Works either way on virtually all class 7 or 8 U-Joints).

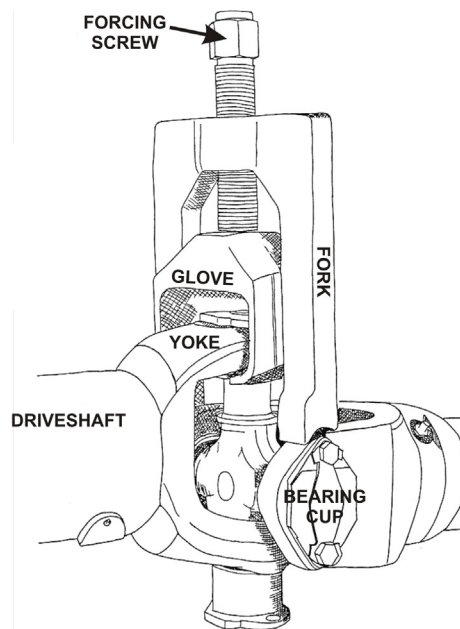

# Operating Instructions

View the Heavy Duty Yoke Puller demonstration video online at [tigertool.com](http://tigertool.com)

**NOTE:** Hammering this tool will void your warranty.

VIDEO  
INSTRUCTIONS



## Half-Round Yoke

- 1 Remove the large nut and washer that retains yoke to shaft.
- 2 Apply penetrating lubricant to splines of the shaft, wing cap bolt holes, and forcing screw of tool.
- 3 Thread the forcing screw into the pull bar until threads begin to show through the other side.
- 4 Hold pull bar assembly by the forcing screw and position the tool onto the yoke.  
**NOTE:** Pull bar end reliefs should face yoke.
- 5 Attach the adaptor cap by four bolts and then tighten down both caps.
- 6 Hand tighten the forcing screw until the center point aligns with the shaft center.
- 7 Using up to a 1" impact wrench, begin applying power to the forcing screw.
- 8 Continue turning the forcing screw until yoke is completely removed.

## Full-Round Yoke

- 1 Remove the large nut and washer retaining yoke to shaft.
- 2 Apply penetrating lubricant to splines of the shaft and forcing screw of the tool.
- 3 With the pull bar separated from the forcing screw, slide the bar through bearing cup bores until centered.
- 4 Thread the forcing screw into pull bar until it contacts the shaft.
- 5 Using up to a 1" impact wrench, begin applying power to the forcing screw.
- 6 Continue turning the forcing screw until the yoke is completely removed.

# Parts Breakdown

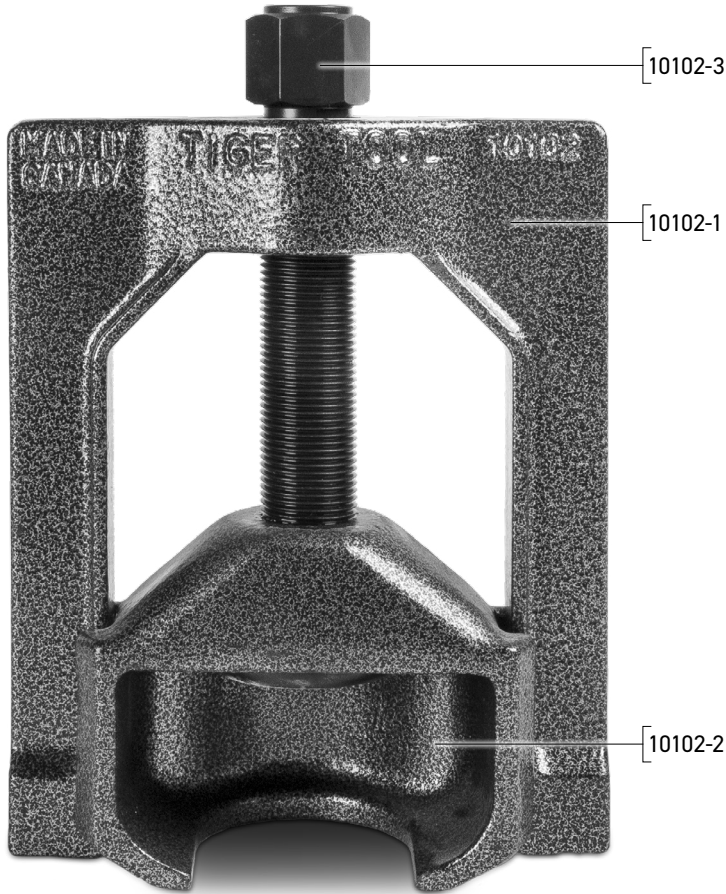

**Maintenance Pack for 10102**  
10101

Maintenance Pack contains each of the following items:

- 2X ——— [10102-5]
- 1X ——— [10102-4]
- 1X ——— [10102-6]

Also available separately.

Part Number	Description	Qty.
10102-1	Fork	1
C10102-2	Glove	1
10102-3	Forcing Screw	1
10102-4	Retaining Bolt	1
10102-5	Washer	1
10102-6	Dome Plug	1

# Parts Breakdown

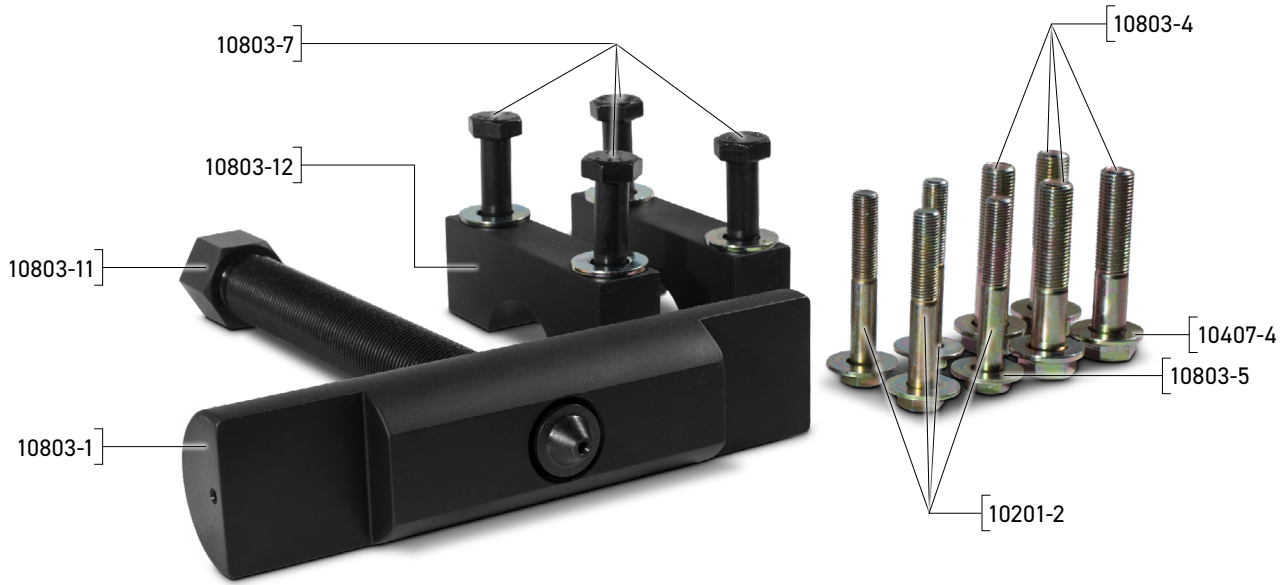

Part Number	Description	Qty.
10803-12	Combined Cap	2
10803-4	1/2" - 20 x 2 1/2" Bolt	4
10407-4	1/2" Washer	8
10803-5	3/8" Washer	4
10201-2	3/8" - 24 x 2 1/2" Bolt	4
10803-1	Pull Bar	1
10803-11	Forcing Screw	1
10803-7	12mm x 1.25 x 70 Bolt	4